

MANUEL SIRGO ÁLVAREZ

Imaginando en papel



SALVATELLA

IMAGINANDO EN PAPEL

Por Manuel Sirgo Álvarez

EDITORIAL SALVATELLA

A Nelly, mi esposa.

© Manuel Sirgo Álvarez

© Editorial Miguel A. Salvatella, s.a.
c/ Sant Domènec, 5 · 08012 Barcelona
Tel.: 93 218 90 26 · Fax: 93 217 74 37
e-mail: editorial@salvatella.com
www.salvatella.com

Primera edición: mayo 2006
ISBN: 84-8412-348-0
Depósito legal: B-24.449-2006
Impresión: Liberdúplex
Printed in Spain

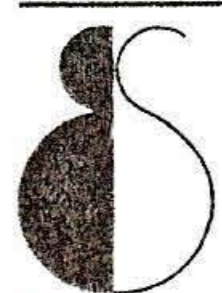

EDITORIAL
MIGUEL A. SALVATELLA S. A.
c/. SANT DOMÈNEC, 5 · 08012 BARCELONA

Prólogo

Hace algunos años que conozco a Manuel y, como en las buenas relaciones, ha habido todo tipo de momentos.

Lo conocí por teléfono, me llamó para pedirme un boletín donde fue publicada su primera figura, la araña tejedora. Más adelante vendría a Zamora, donde asistimos a la convención de la AEP. Al año siguiente nos vimos en Santiago, después en Zaragoza y la última vez que lo vi fue en la convención de Barcelona.

Después de esa primera figura en «Pajarita», vinieron muchas creaciones. Sus figuras podían verse en varios boletines de papiroflexia del mundo, y como culminación llegó la publicación de su primer libro; hecho que le abrió más puertas.

El libro y las exposiciones que organizaba en cada convención hacían que las personas de otras nacionalidades asistentes a las mismas pudieran contemplar el increíble número de creaciones, que año tras año aumentaba de manera sorprendente. En Santiago logró la admiración de Kamiya, en Sevilla la de Hojyo Takashi, quienes hablaron de Manuel en Japón y escribieron sendos artículos para la *Origami Tanteidan*, también seleccionaron trabajos suyos para los boletines anuales. Después obtuvo el mejor premio: ser invitado a, en mi opinión, la mejor Convención Internacional; Italia.

Manuel es un emprendedor y un luchador, para él no existe la palabra miedo, en menos de un año creó 80 figuras, tomando notas de ellas en unos bocetos a mano alzada, bocetos que sirvieron a Anibal Voyer para llevar a cabo los dibujos de su primer libro. En Zamora, pude admirar este increíble trabajo y la selección que había hecho para el libro. Allí también pude apreciar las ganas de Manuel de colaborar con la asociación. Cuando aceptó la edición del Boletín, no sabía nada de dibujo por ordenador ni de maquetación, pero dijo: «todo está en los libros», al poco tiempo salió el número siguiente de *Pajarita* sin notarse el cambio de editor.

Al cabo de unos años, invité a Manuel a una reunión de amigos en Zaragoza, más sorpresas, aceptó la invitación, y en la sala donde nos reunimos, pude ver a una persona más alegre, dinámica, habladora, y a la vez, apreciar en sus modelos grandes mejoras desde el punto de vista de la creación: figuras más cuidadas, la elección de papeles era perfecta, diversidad de técnicas, modo de presentación. Expuso más de 100 figuras, sólo una palabra INCREÍBLE..., la gente participante en aquel encuentro enmudeció ante aquel despliegue de todo tipo de animales que desfilaron ante nosotros: aves, mamíferos, animales mitológicos y, sobre todo, INSECTOS.

Desde entonces, nuestra comunicación ha sido fluida y me comenta sus nuevas creaciones, me enseña fotos de sus modelos, habla de la manera de crear un tipo de papel apropiado para cada figura, del estudio del cuadrado para realizar sus creaciones. Sé que a esa madurez llegó tras la lectura de *Origami Desing Secrets* de Robert Lang.

Después de Italia, me prometió abandonar los insectos para volcarse en la creación de otro tipo de figuras, cosa que sólo ha cumplido a medias. Manuel se volvió más reflexivo y más estudioso de sus figuras, los acabados y la técnica. Su método de creación y de plegado han evolucionado y vais a tener la oportunidad de comprobarlo en este libro, donde Manuel nos sorprende con 21 figuras de un altísimo nivel, no sólo insectos, aunque es lo que predomina, también nos presenta figuras que pueden plegarse con papeles de gramaje más alto e, incluso, en algunas es posible lanzarse al plegado en húmedo, con papeles más gruesos, como es el caso del dugón, narval, león marino y cocodrilo;

Este libro es la recopilación de un estudio muy profundo de la figura y el método de plegado, las mejoras en estos aspectos a sí vais a comprobar ya desde la primera figura y los resultados serán los que todos esperamos, INCREIBLES

Lo que más me sorprende de Manuel es que teniendo una familia que atender, mujer y dos niños, y sus clases, con lo que ello conlleva de tiempo de preparación, aún le quede tiempo para diseñar modelos e incluso dibujarlos. Por cierto, me encantan sus dibujos a mano alzada.













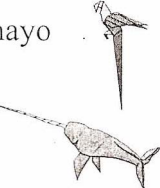



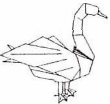

Manuel es una persona que pasa desapercibida, introvertido, muchas veces lo he visto pasear solo, con un papel entre las manos, ensimismado, pero cuando lo descubres, encuentras a una persona entrañable y llena de sensibilidad

Después de muchos años en el mundo de la papiroflexia he aprendido que según cómo un plegador trate el papel es más o menos sensible. No hay nada más que estar un instante con Manuel para conocer su gran sensibilidad y su buen hacer

Gracias Manuel por todo lo que me has enseñado

Felipe Moreno

Índice

Prólogo	3
Índice	5
Introducción	7
Plegado de los inodelos	9
Instrucciones de plegado	13
Acciones de los símbolos	14
Dificultad de los modelos	17
 Cisne nadando	19
 Guacamayo	27
 Dugón	36
 Narval	43
 León marino	46
 Viuda negra	51
 Falangio	59
 Raya	63
 Cocodrilo	76
 Estrella	91
 Cisne	99
 Leptynia hispánica	120
 Pharnacia	128
 Mantis hoja	136
 Hormiga negra	150
 Cangrejo de río	165
 Pseudoescorpión	181
 Escorpión Buthus	197
 Cyclommatus Imperator	202
 Ciervo volante	223
 Dynastes Neptunus volando	235

Introducción

Imaginando *en Papel* es el segundo libro que publico sobre figuras de origami. Como en cualquier libro, pueden enunciarse varios objetivos que se pretenden con el mismo. Sin hacer ejercicio de vanas pretensiones, en realidad solamente intento explicar cómo se hacen algunas de mis figuras de papel sin compromiso de crear una periodicidad, sin embargo sí con el ánimo de ir dibujando poco a poco mis modelos, atendiendo con ello a la petición de amigos de nuestra afición a doblar papelitos, que me han hecho desde que se publicó *Papiroinsectos*, mi primer libro.

En esta obra también se va a encontrar una explicación sobre técnicas de plegado, acabado de modelos y preparación de papeles para las figuras del libro, que expone magistralmente Pere Olivella experto plegador, que ha hecho todos los modelos del libro.

Sobre creación en papiroflexia todavía no me siento suficientemente preparado para escribir (todo llegará). A menudo me preguntan cuál es el método que sigo para diseñar mis modelos. Mi respuesta suele ser que sería capaz de explicar cómo empecé, pero no cómo los creo ahora. Cuando comencé lo hacía tomando una base clásica, observando las puntas, longitud, etc. de la misma y viendo qué modelos podían surgir de ella. Y comenzaba desde la base a doblar y doblar hasta que mejor o peor llegaba al modelo que me había propuesto. Así, de la misma base, «bomba de agua» plegué una tortuga, un oso y un orangután, todos con algo en común, cuatro puntas largas y una corta. Recuerdo que por aquel entonces le pregunté a Anibal Voyer su opinión sobre esta forma de empezar a aprender a crear y él me dijo que le parecía una manera estupenda, respuesta que me animó mucho.

Poco a poco fui cambiando de método. Primero fijaba el modelo y después la base conocida que más se aproximaba al mismo. Modificaba la base y partiendo de la base modificada — estirando, duplicando, triplicando puntas, etc.— plegaba el modelo. Todavía hoy sigue siendo un método que aplico muchas veces, pues soy un poco vago para crear bases nuevas. Sólo las creo cuando me veo ante un modelo del que tengo mucho empeño en hacer y no encuentro ninguna base modificable apropiada. La razón es que a mí lo que más me gusta es el proceso que va desde la base hasta el modelo final. Dejo a mis dedos con el papel, intentando llevar los pliegues con ellos por el camino que el propio papel me va marcando o creo que me marca. La base no digo que no sea importante, simplemente me motiva menos. En la actualidad utilizo varios métodos.

Esto conlleva que en no pocas ocasiones el empleo del papel no esté optimizado, tendencia ésta muy al uso en el moderno origami. Lo siento, no sigo métodos matemáticos para optimizar. Algún modelo lo he diseñado con esas técnicas que valoro profundamente cuando las emplean otros creadores, pero que me divierten poco cuando las aplico a mis modelos (al menos por el momento). De haberme centrado en el empleo de estas técnicas de diseño estoy seguro de que en vez de los más de doscientos modelos que tengo hechos en cinco años tendría como mucho la quinta parte.

En el libro hay modelos fáciles, intermedios, difíciles y muy difíciles. La clasificación que sigo es muy subjetiva y arbitraria. Los modelos «muy fáciles» (nivel 1) son aquellos que yo considero aptos para enseñar a niños. En este libro no hay ninguno. El nivel más bajo de los modelos de este libro es el 2. Los modelos de este nivel son modelos «fáciles», requieren saber hacer las bases simples: cometa, pez, pájaro, rana y sus modificaciones. En el libro hay cinco. Otros cinco modelos son de nivel 3, ((intermedios)). Para éstos hay que saber manejarse bien con las bases blintz y técnicas de sink abiertos y cenados y cambios de color. Cinco modelos más entran en la categoría de «difíciles» (nivel 4). Este nivel requiere ser un experto plegador de todo tipo de bases y usar todas las técnicas flécticas por complejas que estas sean (unsinks, plegado con apertura de modelo, etc.). En el nivel 5, «muy difíciles») entran 6 modelos. En este nivel se requiere lo mismo que en el 4, pero además se le pide más al papel. Para un plegado de calidad son necesarios papeles especiales y técnicas de acabado del modelo.

Plegado de los modelos

Antes de plegar un modelo es muy importante elegir el papel adecuado. La mayoría de modelos aceptan el uso del papel sandwich. El papel sandwich es el papel metalizado de cocina, tipo Albal, al que se le pega un papel de seda en cada cara. Se puede pegar con cola de barra, cola blanca diluida, látex diluido, pegamento en spray... En Internet hay varios artículos detallados acerca de su fabricación. Permite preparar el papel del color que necesitamos, incluso bicolor, y decidir el grosor, pegando el papel de seda en una sola cara, a costa de restarle rigidez. Lo aconsejable es preparar el papel sandwich pegando papel de seda en ambas caras para evitar que se vea la parte metalizada en algunos pliegues, además aumenta su rigidez y facilidad de plegado. Plegar con el papel sandwich es algo delicado, pero con la práctica es el tipo de papel más agradecido, porque permite modelar directamente en el proceso final. Para plegar el papel sandwich es básico que se alise cada pliegue que se marca, como si intentásemos borrarlo.

Otro papel bastante adecuado es el papel metalizado. Éste es más grueso que el sandwich, pero sigue siendo fino, y permite el modelado final con facilidad. Hay varios recursos para conseguir el color que nos interesa del papel metalizado. Es un papel que se vende en rollos, tiene una cara metalizada, hay de varios colores, y otra cara blanca. Se puede pegar seda como en el sandwich, lo que aumentará el grosor y perderá algo de moldeabilidad. Otro recurso, que uso habitualmente, es pintar la cara blanca con una base de t mpera mezclada con látex, diluida en agua. Con el látex consigo que la t mpera no se degrade al hacer los pliegues y una textura más satinada. La cantidad de agua dependerá de la densidad de pintura que deseéis. A menos agua, más s lido y grueso queda el color, con más agua, el color queda más diluido, se extiende mejor al pintar y no aumenta tanto el grosor final. Hay un producto, el AQUALUX de la marca Tit n, que es t mpera con látex, y lo utilizo directamente. Lo aplico con un rodillo peque o para que el resultado sea m s homog neo.

El papel metalizado as  tratado no se rompe con la facilidad con que lo hace si se utiliza sin tratar. Igual que con el papel sandwich, es b sico alisar cada pliegue que se marca. En ambos casos uso la u a para marcar los pliegues, ya que cuanto m s fuerte se marca, m s f cilmente se pliega. Y para facilitar los pliegues hundidos o sinks, es mejor marcar en valle, alisar, plegar en monte y alisar, as  el sink se realiza m s f cilmente.

Varios modelos del libro pueden plegarse perfectamente con la t cnica del humedecido. Para ello se usan papeles que contienen cola en su composici n, y al humedecerse, se reblandecen y se pliegan con facilidad. Se deben usar pinzas u otros sistemas de sujeci n para que guarde la forma final, y al secarse, el modelo queda perfectamente r gido y con la forma deseada. Los papeles m s adecuados son el Canson Mitentes, de 160 gr, y el Ingres, de 100 gr. En Internet hay varios art culos detallados sobre esta t cnica.

Los papeles artesanales son otra posibilidad. Hay mucha variedad de texturas, grosores y colores, pero la gama de colores es m s limitada que la del papel de seda. Existe cierta dificultad para encontrarlos, venden estos papeles en pocas tiendas y hay poca variedad. Una opci n es comprarlo por Internet, aunque resulta caro y a menudo las empresas de distribuci n exigen un pedido m nimo que supera las necesidades individuales.

Las ventajas de utilizar papeles artesanales son varias: una textura m s agradable y realista; m s duraci n de los modelos ante el paso del tiempo; y mayor facilidad al realizar pliegues complejos, como los pliegues hundidos (sinks), se pliegan tal cual sin tener que prepararlo. Tambi n tiene inconvenientes, como la complicaci n de preparar un artesanal bicolor. Quiz  lo m s f cil sea utilizar un pegamento en spray y pegar seda u otro papel artesanal, esto  ltimo puede aumentar peligrosamente el grosor del papel, y no ser apto para modelos m s complejos. Otro inconveniente es que no se pueden modelar, no aguantan la forma, incluso muchos de ellos abren los pliegues con facilidad, por lo que

hay que utilizar productos como la metilcelulosa para dar acabados al estilo de la técnica de papel humedecido.

De los papeles artesanales que he podido probar, el realizado con fibras de banano es el de mejor resultado. Mantiene los pliegues bastante bien sin necesidad de utilizar ningún producto, aunque se mejora el resultado si se utilizan. Los papeles de Lokta pueden ser muy finos o bastante gruesos. En ambos casos requieren metilcelulosa para el acabado final.

La inetilcelulosa es la cola que se utiliza para pegar el papel de decoración en las paredes. Se vende en forma de polvos que se han de diluir según las indicaciones de cada marca. Prefiero usar una mezcla más densa, casi gelatinosa, porque empapa menos, no deforma tanto la zona donde se aplica y se seca antes. Según el modelo que esté plegando, aplico la metilcelulosa durante el proceso de plegado, o exclusivamente al final. Es importante aplicarlo en una o pocas zonas y dejar secar antes de seguir aplicando en otras. Para que la zona quede con la forma que descamos, tendremos que usar pinzas de la ropa u otros sistemas que sujeten el modelo. Si lo aplico a un insecto, por ejemplo, primero doy forma y endurezco el caparazón, luego la cabeza, las antenas y las patas al final. Si empezase por las patas, quizá al formar el caparazón, me podrían cambiar la orientación en que las había dejado y tendría que retocarlas.

La ventaja de la metilcelulosa es que endurece el papel sin pegarlo, y si no queda bien, se puede humedecer ligeramente y volverle a dar forma. Es un proceso lento, y requiere varios días para acabar el modelo. Otra ventaja es que adelgaza el papel, con lo que ayuda a conseguir un efecto de patas más finas, pero duras.

La metilcelulosa ayuda al acabado final del plegado de los modelos, pero no hace milagros. Hay que plegar bien un inodelo y ser preciso en los pliegues para que el resultado sea bueno.

Otros papeles que pueden usarse están explicados por Manuel Sirgo en este mismo libro, que son el papel de seda tratado, el doble seda tratado y el lokta endurecido con cola blanca.

Algunos pequeños consejos, ayudas u orientaciones para plegar los modelos del libro:

Los modelos de nivel 2 son bastante asequibles para un nivel iniciado en papiroflexia. A partir del nivel 3, el aumento de la dificultad exigirá de vuestra parte mayor atención en la precisión de los pliegues. No significa que en los modelos anteriores no haga falta ser precisos, pero perdonan más las imprecisiones.

Los modelos del nivel 3 permiten perfectamente usar papel metalizado, incluso de 15x15, aunque se conseguirá un resultado más fácil usando *sandwich*. El cocodrilo permite, casi exige, usar papeles algo más gruesos, y plegando el inodelo en mayor tamaño se podría utilizar canson. Este papel algo más grueso ha de ser artesanal como el lokta grueso, incluso el batik (aunque este último requiere gran esfuerzo por el volumen de las capas), y requiere del uso de la inetilcelulosa, humedeciendo las zonas que requieren de modelaje.

En el nivel 4 y 5 la precisión de los pliegues es determinante. El papel más adecuado es el sandwich o papeles artesanales más finos como el lokta fino, el papel de fibra de banana, el seda tratado...

El guacamayo se puede plegar con cualquier tipo de papel y tamaño hasta 15x15, es un modelo muy agradecido por sujetarse en el dedo, como una mascota.

El cisne nadando agradece un papel más moldeable, como metalizado o sandwich, con lo que se consigue darle mejor forma y aumentar su elegancia.

Para conseguir un buen resultado, dar aspecto satinado, he recubierto la cara blanca del papel metalizado con látex diluido, aunque no haría falta; y a la cara metalizada le he pegado papel de seda negro. Los siguientes modelos, el león marino, dugón y narval, han de plegarse con papel moldeable metalizado, o papeles gruesos usando la técnica del humedecido para conseguir darles un volumen y una expresión mejores. El sandwich no lo aconsejaría porque quizá quedaría un modelo final demasiado endeble. Son modelos de poca dificultad y muy agradecidos.

El narval lo he plegado con papel metalizado, pegando un papel de seda oscuro por el lado metalizado, y dejando el lado blanco sin tratar, para conseguir el color y la forma del cuerno con facilidad. El león marino y el dugón los he plegado con papel lokta grueso, utilizando para los acabados

metilcelulosa, dando forma al modelo en las zonas del cuello y cara, con ayuda de pinzas para que se seque correctamente.

La viuda negra y el falangio comparten la base, pero tienen terminaciones diferentes. Estos modelos se pliegan perfectamente con papel sandwich y metalizado, con lo que se consigue dar fácilmente la forma final.

El cocodrilo y el águila de mar o raya de mar permiten ser plegados con una gran variedad de papeles, incluso algo gruesos. He plegado los dos modelos con papel lokta. En el cocodrilo hubiese agradecido un papel más rígido, como el ingres, para facilitar el paso 114.

En los modelos de dificultad 4 y 5 pocos consejos podría dar. Como he dicho antes, aquí la elección del papel es determinante y la precisión de los pliegues marcará la diferencia entre acabar el modelo o plegar un buen modelo.

La Leptynia hispánica y la hormiga negra quedan perfectamente acabadas siguiendo el proceso de plegado. En el caso de la pharnacia, el mejor efecto viene al hacer el paso 86, en el que hay que redondear completamente el modelo y forzar un poco las patas para ponerlas en el sitio. La mantis hoja requiere de un cuidadoso modelaje final para conseguir el efecto del modelo. Para ello aconsejo mirar fotos del modelo terminado por Manuel Sirgo.























El cangrejo de río se ha de plegar con un papel grande, mayor de 30x30, al menos 50x50 en una primera tentativa. Este modelo, junto con el pseudoescorpión y el buthus, requiere de un cierto modelaje final para conseguir buenos modelos.

El ciervo volante y el cyclommatus imperator tienen un proceso que llega fácilmente al resultado final, simplemente requerirán un pequeño modelaje del abdomen.

El Dynastes Neptunus es el modelo más complejo del libro. Hay que prestar atención especial al paso 75, fijándose cuidadosamente en todas las indicaciones y atendiendo a los pasos intermedios 76 y 77, para llevarlo a cabo sin errores.

Pere Olivella

Instrucciones de plegado

	<i>Pliegue en valle</i>		<i>Hundir, aplastar</i>
	<i>Pliegue en monte</i>		<i>Volver el modelo</i>
	<i>Visión por transparencia</i>		<i>Girar el modelo</i>
	<i>Marca</i>		<i>Dibujo aumentado</i>
	<i>Plegar hacia delante</i>		<i>Dibujo disminuido</i>
	<i>Plegar hacia atrás</i>		<i>Sujetar por</i>
	<i>Plegar hacia dentro</i>		<i>Estirar</i>
	<i>Repetir</i>		<i>Color abajo</i>
	<i>Plegar y desplegar</i>		<i>Color arriba</i>
	<i>Pliegue escalonado</i>		<i>Color igual por las dos caras</i>
	<i>Escalonado hundido</i>		
	<i>Desplegar</i>		

Acciones de los símbolos

A continuación se exponen algunas de las acciones de los símbolos para plegadores noveles.

Pliegue en valle

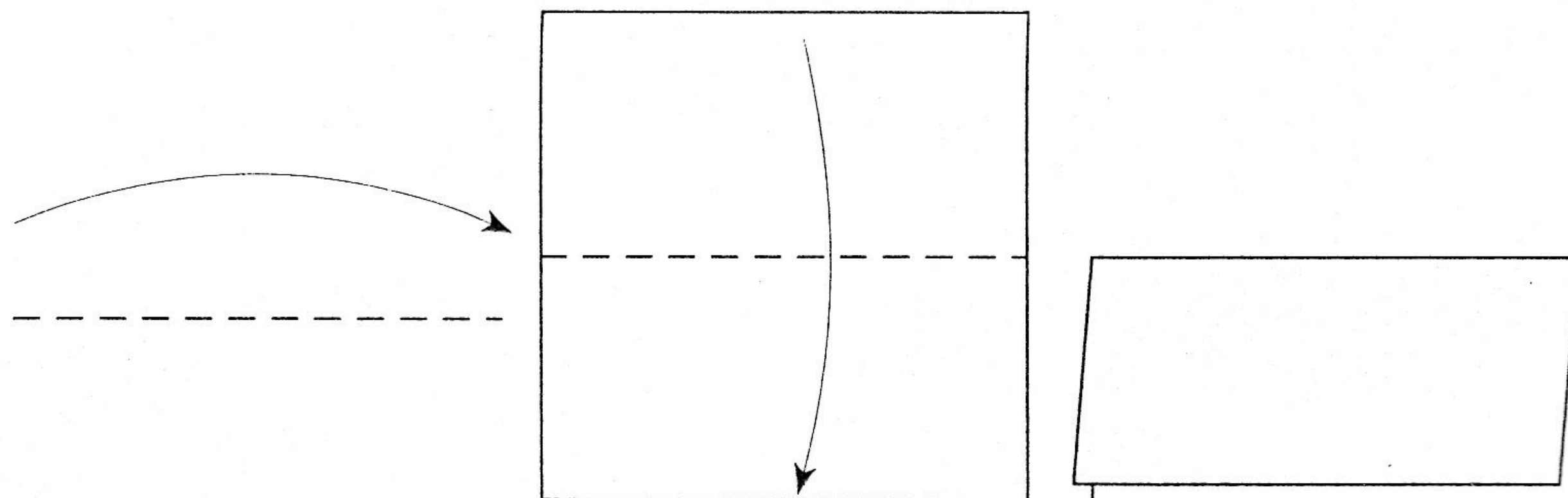

Un pliegue en valle es indicado por una línea de segmentos y una flecha, con una cabeza simétrica, que indica el movimiento del papel. En este ejemplo se pliega el papel por la mitad, llevando el lado superior hasta encontrarse con el inferior.

Pliegue en monte

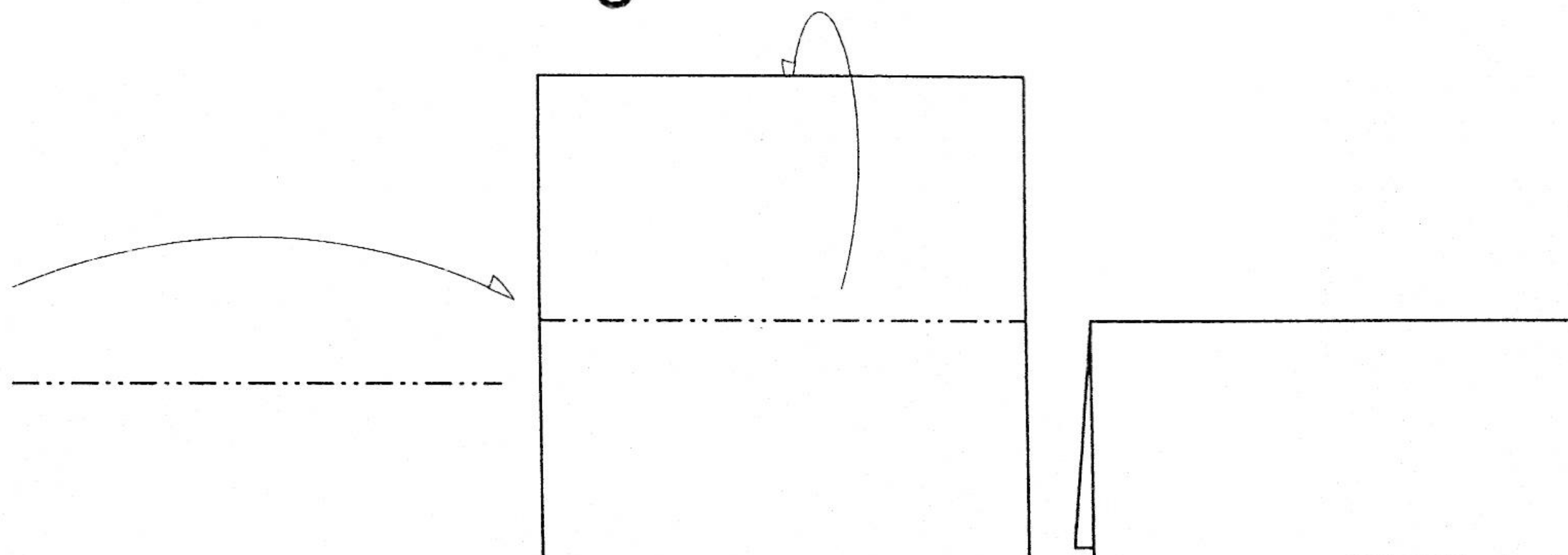

Un pliegue en monte es indicado por una línea de puntos y segmentos y una flecha, con una cabeza asimétrica, que indica el movimiento del papel. En general, cuando aparecen estos tipos de flechas, el papel se ha de plegar alejándolo de nosotros, justo lo contrario que ocurre en los pliegues en valle.

Plegar y desplegar

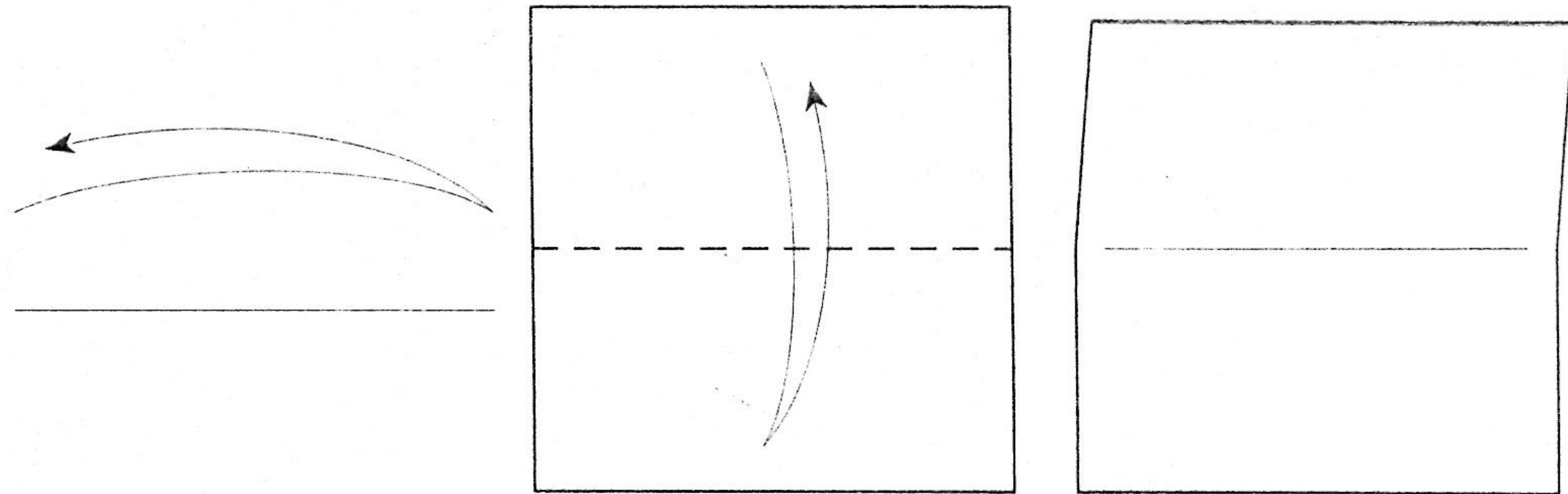

Este símbolo nos indica que debemos doblar igual que en el pliegue en valle y cuando lo hayamos hecho lo desdoblamos dejándolo en su posición original, con la única diferencia de que nos aparecerá una cicatriz por la línea de plegado.

Pliegue escalonado

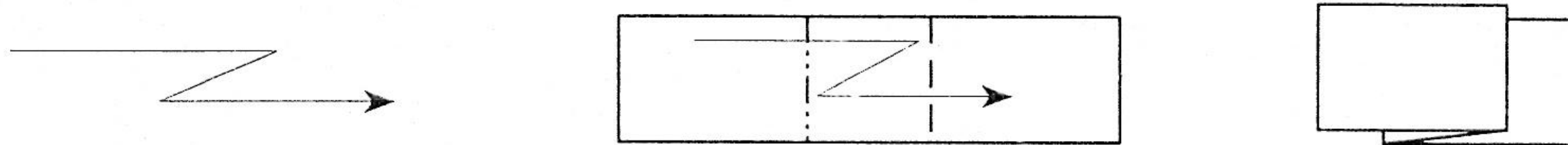

Consiste en hacer un pliegue en valle y otro en monte. La flecha, como siempre, nos indica el movimiento del papel y además es una representación del resultado final del papel plegado visto por el canto.

Pliegue volteado

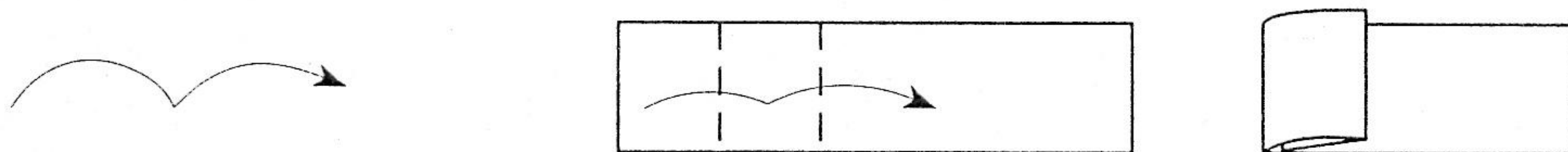

Consiste en hacer dos o más pliegues consecutivos hacia el mismo lado, pueden ser valles o montes, el proceso es el mismo.

Hundir

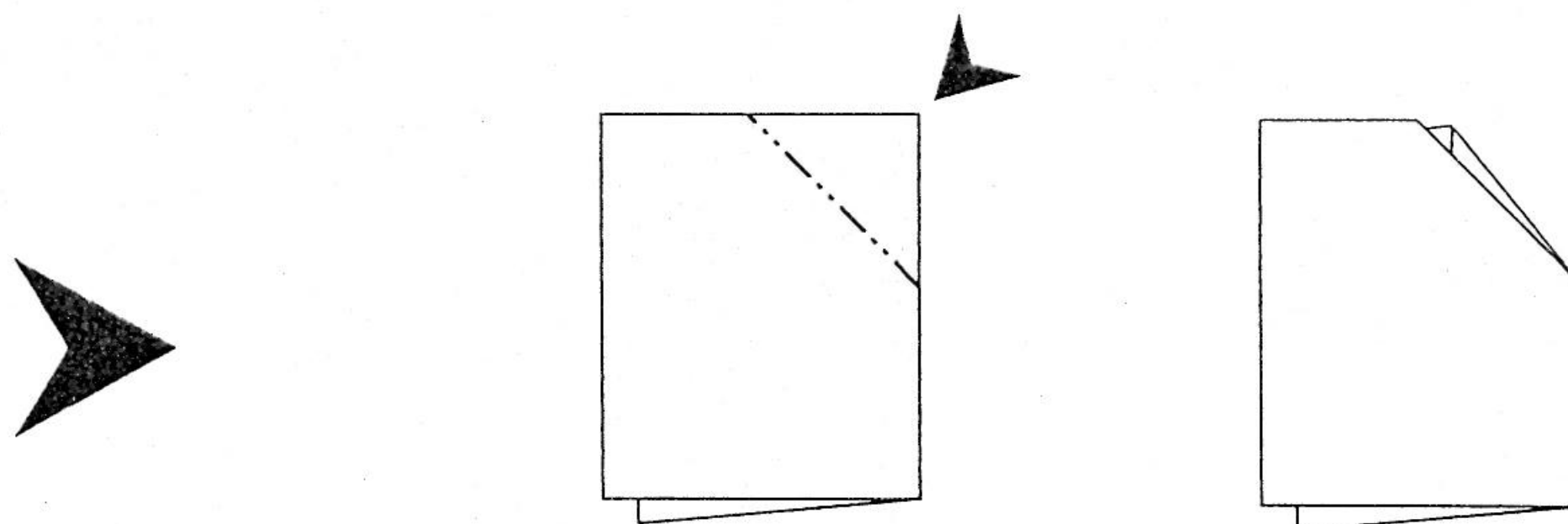

Consiste en empujar una punta hasta que se consigue hundirla volviendo a dejar el modelo plano como estaba.

Girar

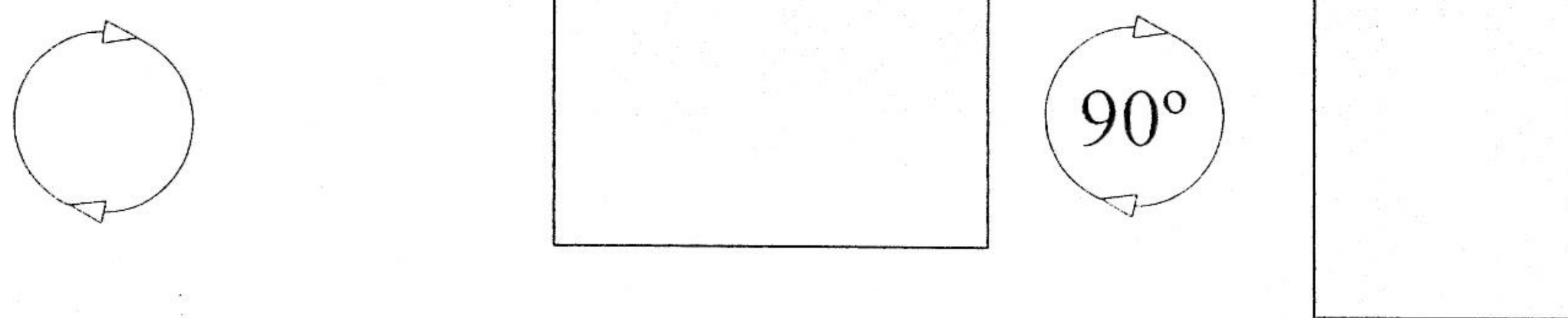

Consiste en rotar el modelo en el sentido indicado por las flechas del símbolo. El ángulo que hay que girar está escrito dentro del propio símbolo.

Volver el modelo

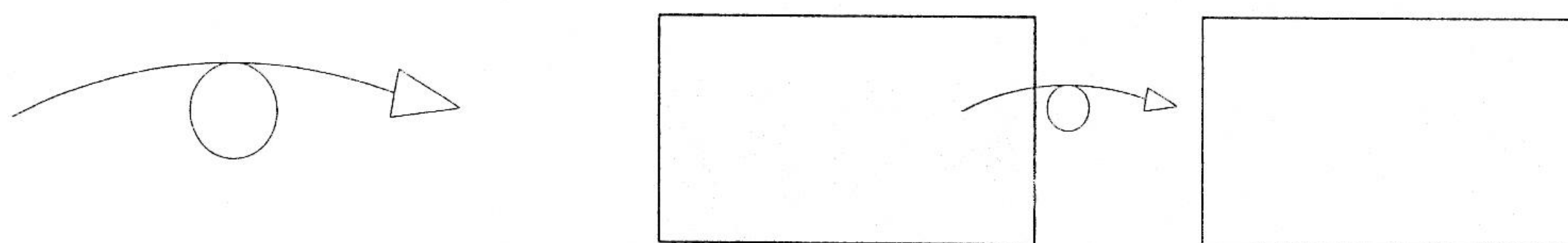

El símbolo consiste en una flecha que hace un loop, indicándonos que debemos coger el papel y volverlo poniendo el lado que estaba sobre la mesa a la vista.

Visión ampliada

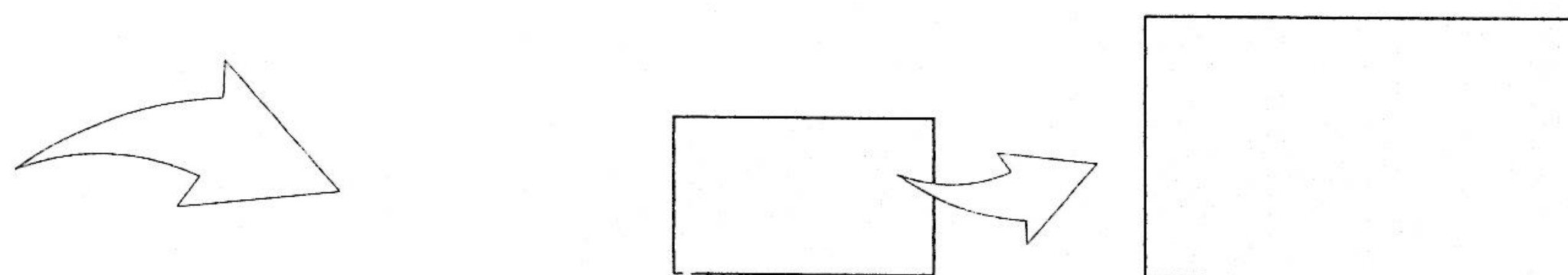

Esto nos indica que en el siguiente paso los diagramas se han dibujado a una escala mayor para facilitar así su entendimiento.

Visión disminuida

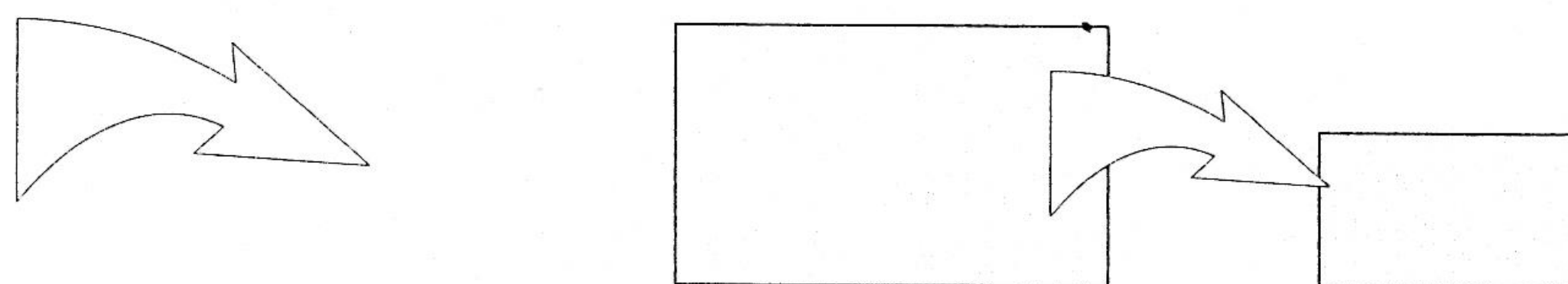

Es frecuente utilizar esta flecha después de haber mostrado algún detalle ampliado de la figura, cuando se ha terminado de plegar esa zona volvemos a dibujar el modelo, pero más pequeño.

Repetir

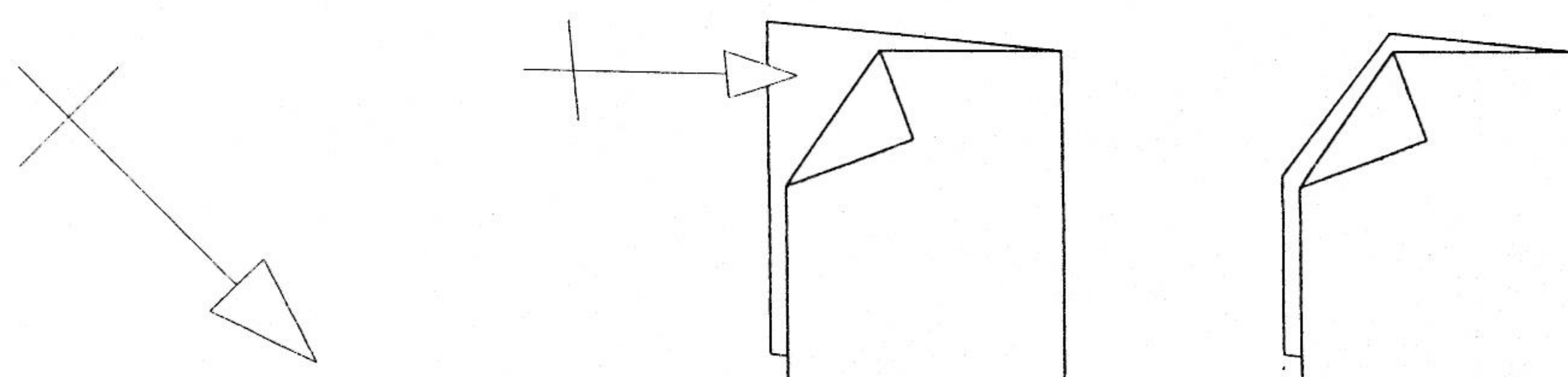

El símbolo nos indica dónde debemos repetir los últimos pasos y cuántas veces tenemos que hacerlo (tantas como rayas tenga la flecha).

Dificultad de los modelos

Los niveles de dificultad han seguido los siguientes criterios:

Nivel 1: Principiante que domine las bases: cometa, pez, pliegues monte, valle, caperuza y bases preliminar y bomba de agua.

Nivel 2: Principiante que domine las bases: cometa, pez, pájaro y rana. Pliegues básicos excepto unsinks.

Nivel 3: Plegador intermedio que domine todas las bases incluida la blintz rana y todos los tipos de pliegues.

Nivel 4: Plegador avanzado, con dominio en modelos que exigen muchos pasos, algunos de ellos con el modelo abierto.

Nivel 5: Plegador avanzado con modelos que requieren papeles especialmente delgados, o modelos con gran número de pasos.

NIVEL 2

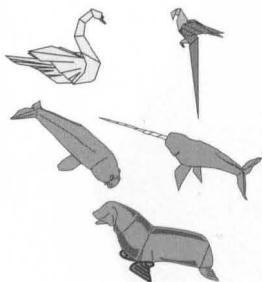

Cisne nadando
Guacamayo
Dugón
Narval
León marino

NIVEL 3



Viuda negra
Falangio
Raya
Cocodrilo
Estrella

NIVEL 4

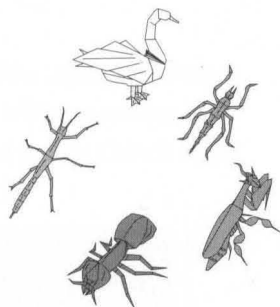

Cisne
Leptynia hispánica
Pharnacia
Mantis hoja
Hormiga negra

NIVEL 5

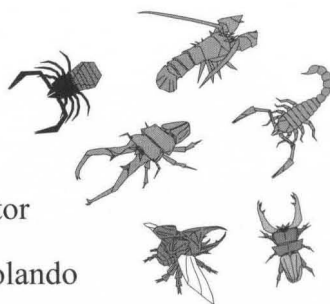

Cangrejo de río
Pseudoescorpión
Escorpión Buthus
Cyclommatus Imperator
Ciervo volante
Dynastes Neptunos volando

CISNE NADANDO

Swan swimming

© M. Sirgo - 2003

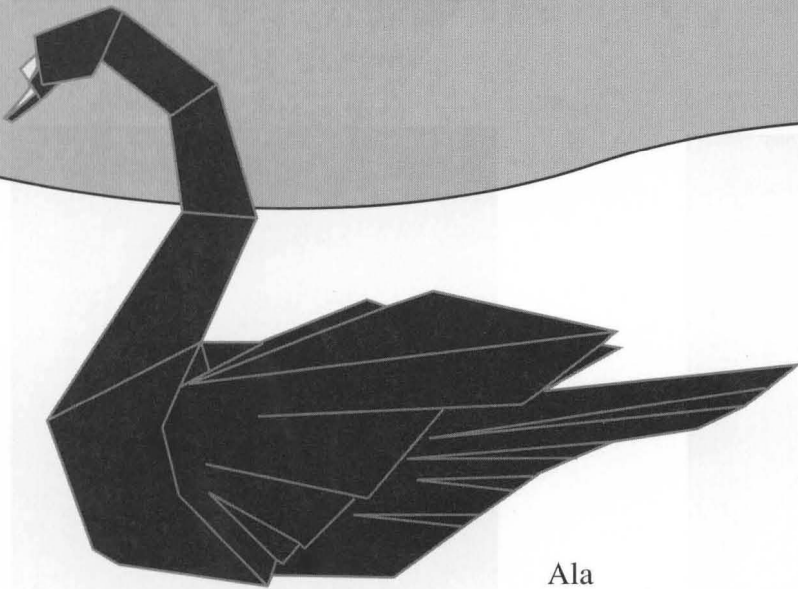
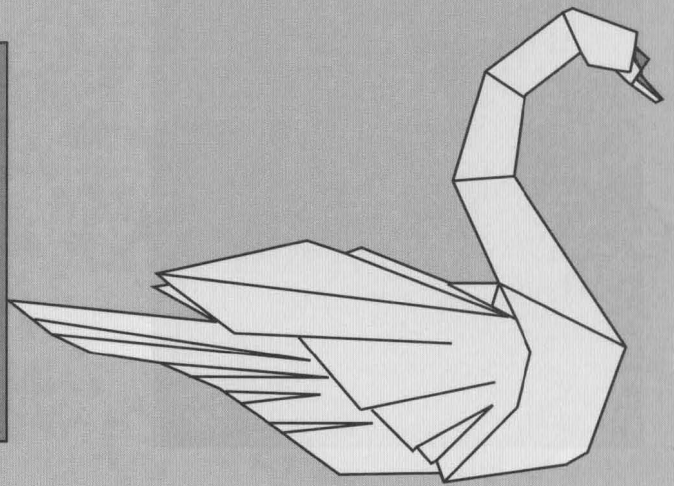

El papel debe ser blanco y naranja para un cisne blanco con el pico naranja o papel negro y rojo para un cisne negro con el pico rojo.

The paper should be white and orange for a white swan with the orange beak or black paper and red for a black swan with the beak red.

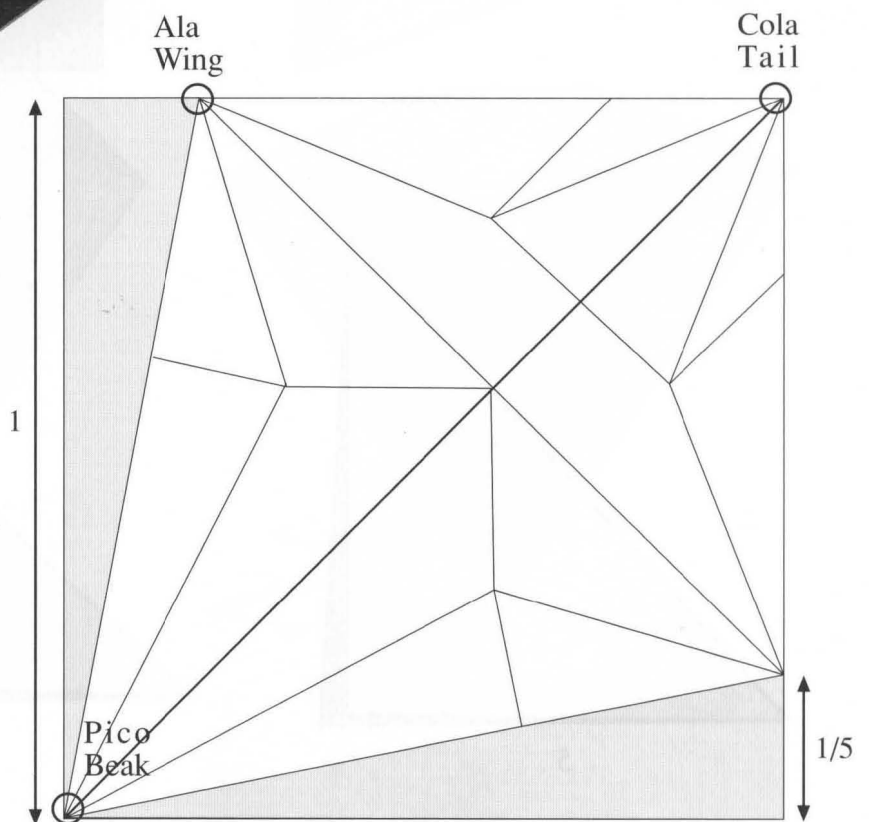
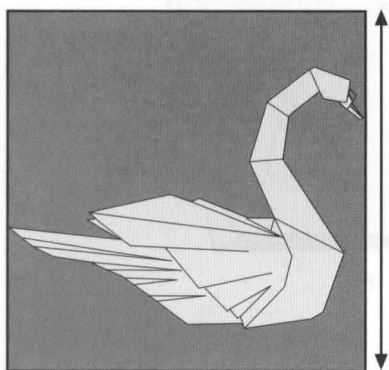

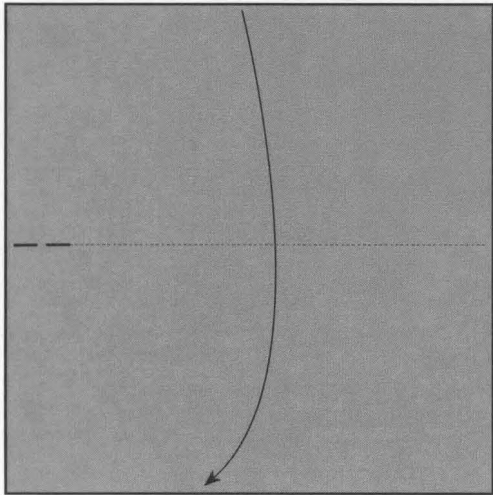

1 

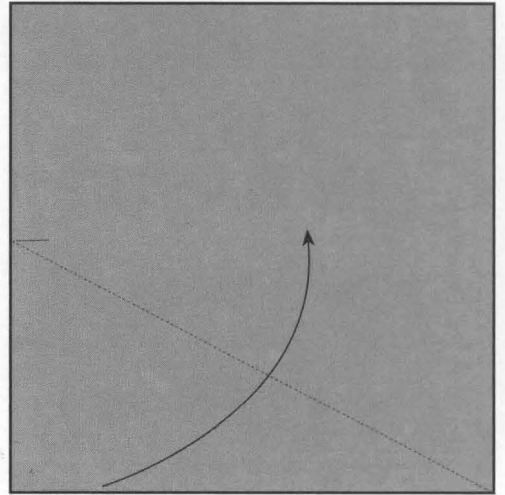

2

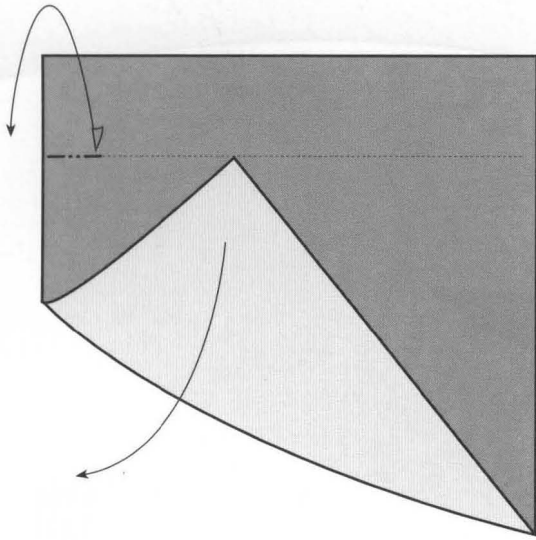

3

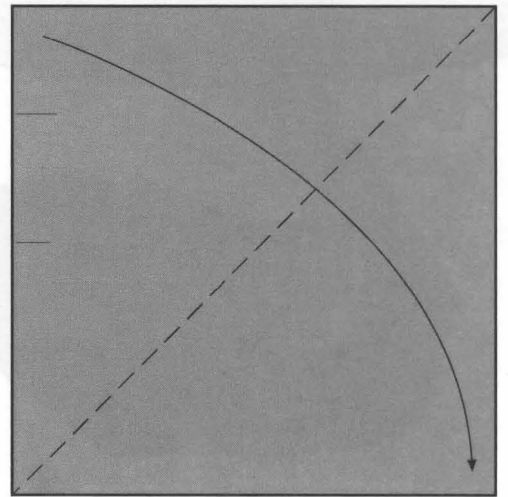

4

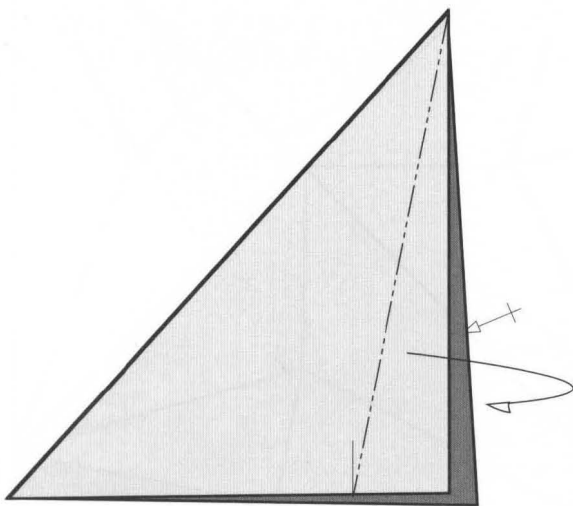

5

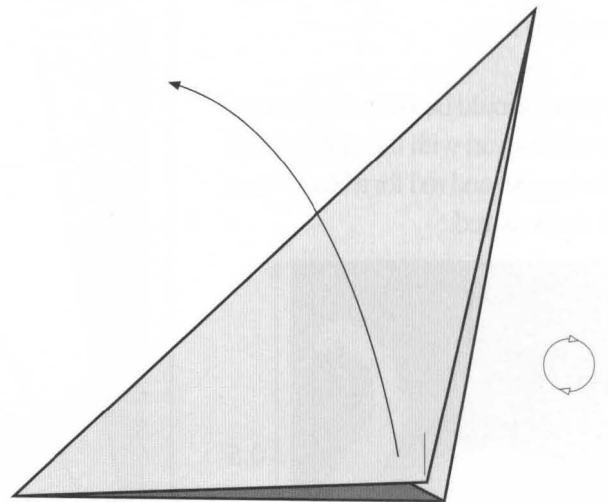

6 

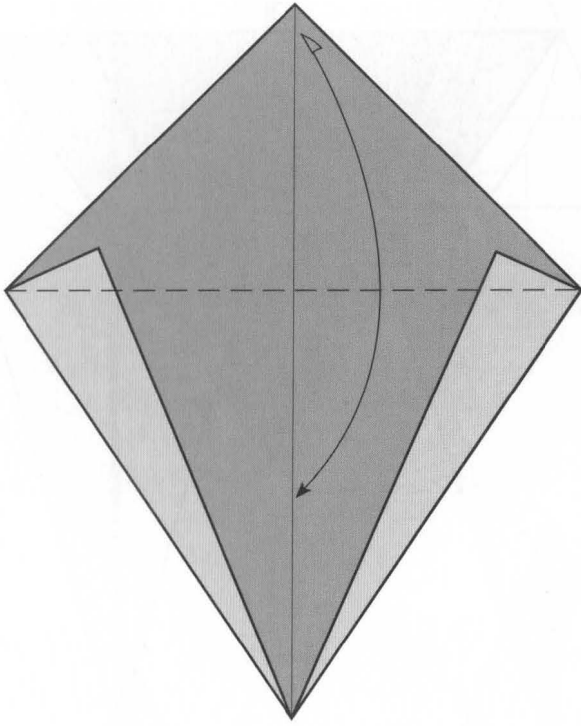

7

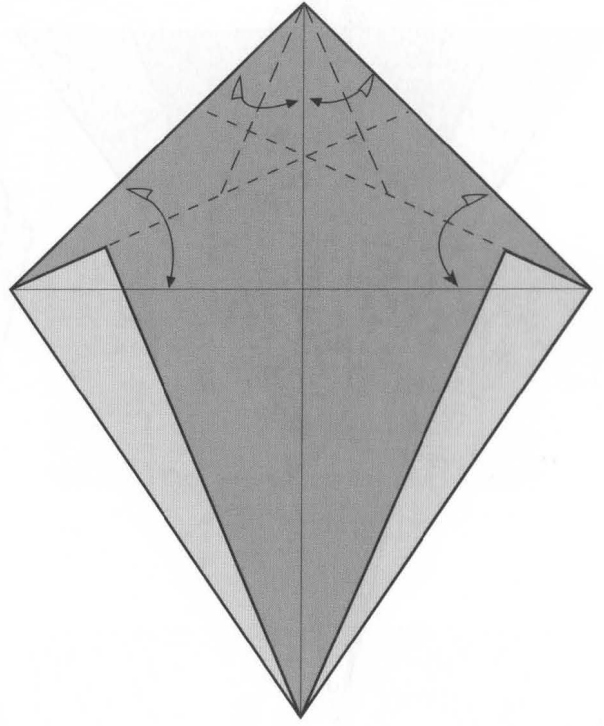

8

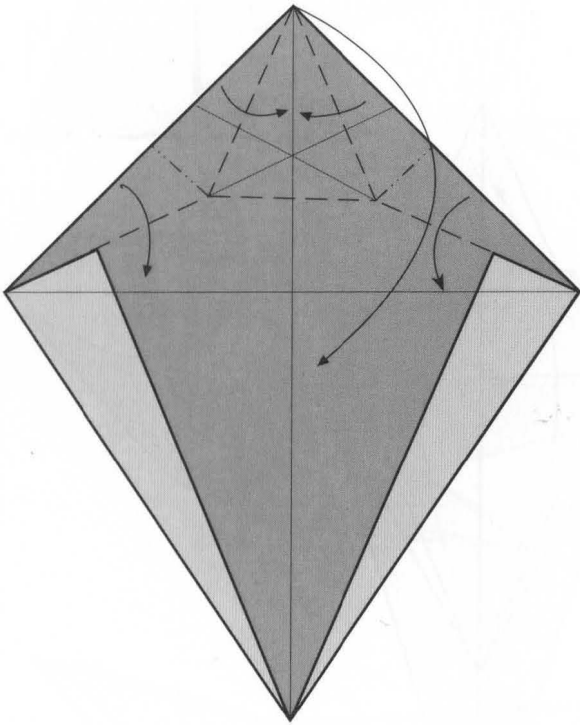

9

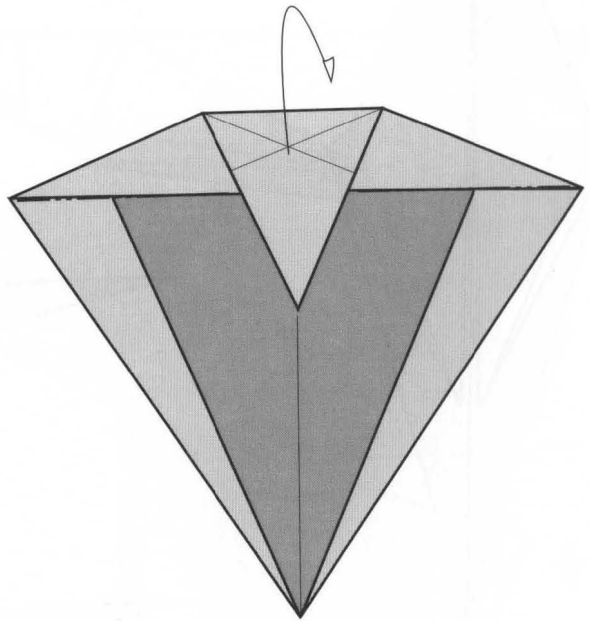

10

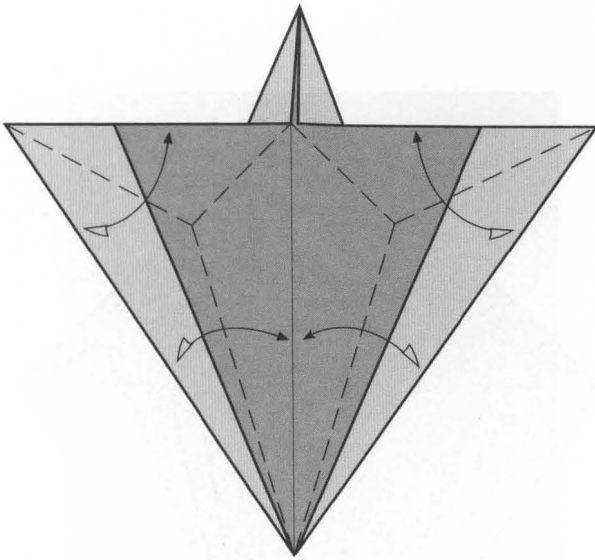

11

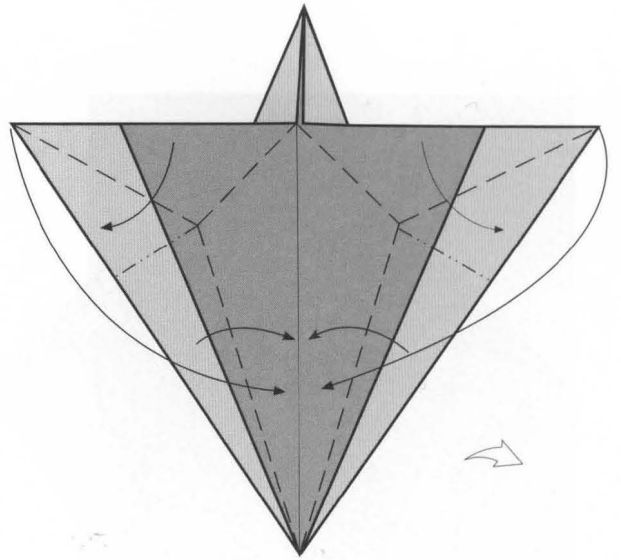

12

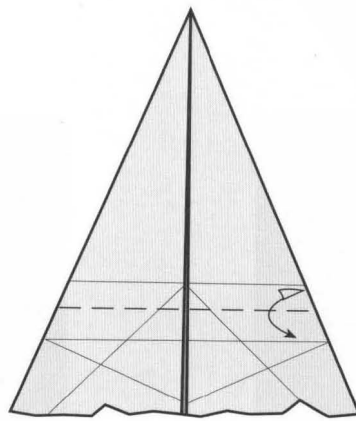

14

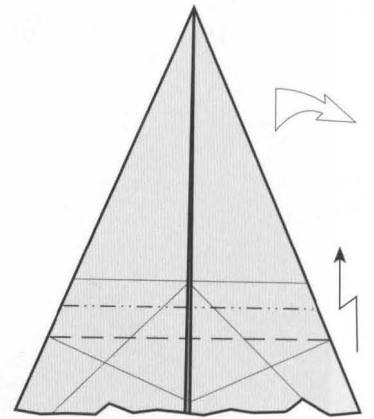

15

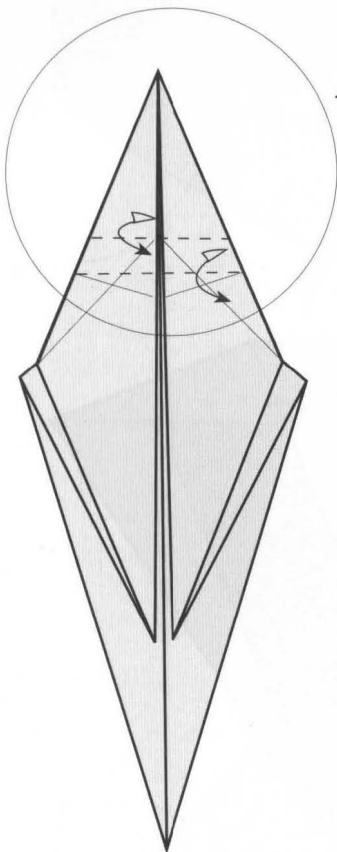

13

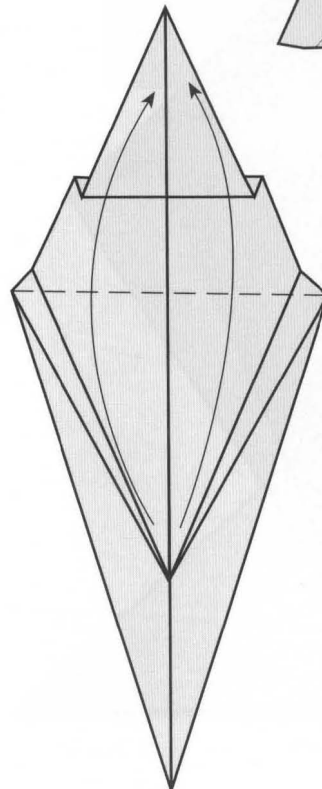

16

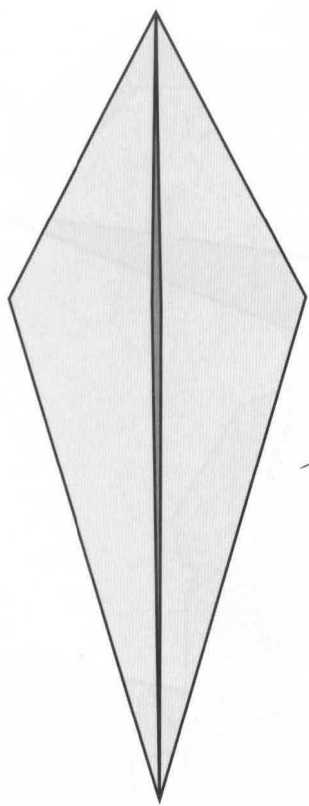

17

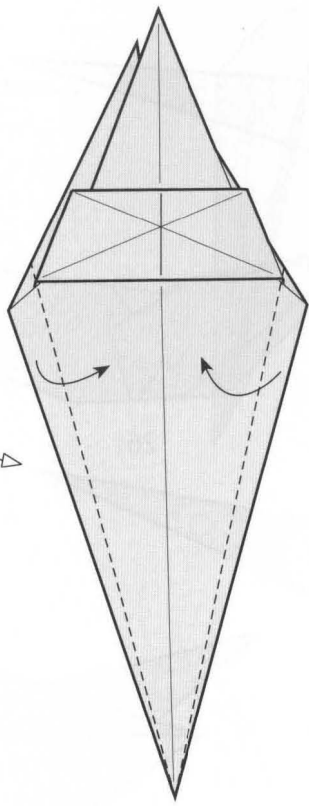

18

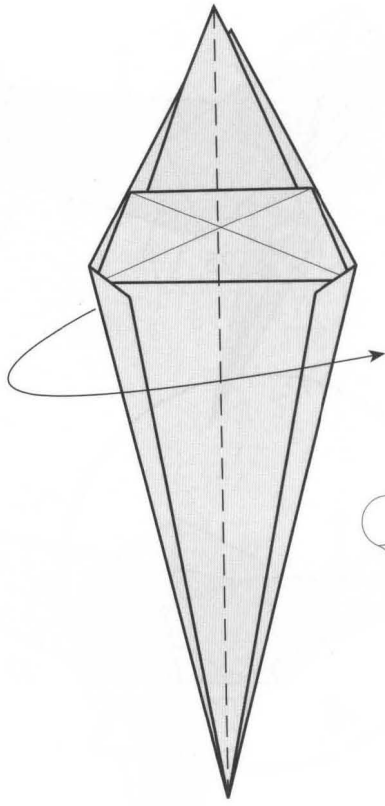

19

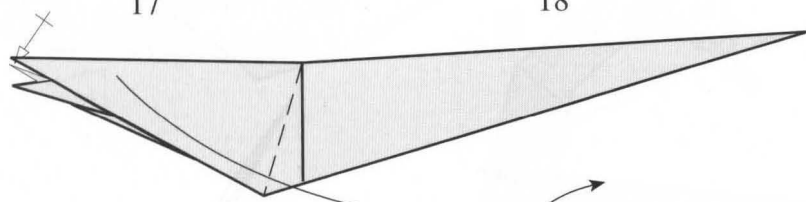

20

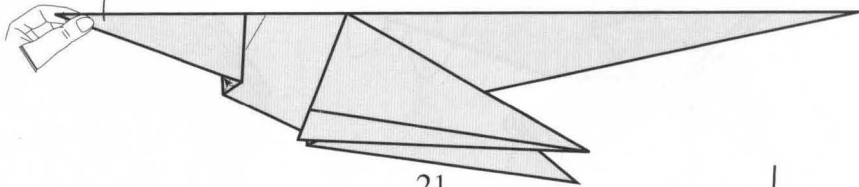
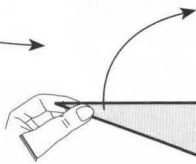

21

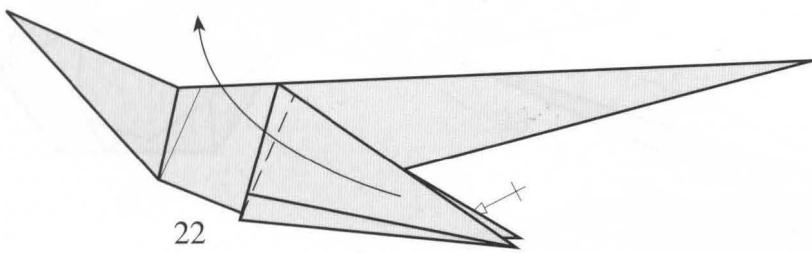

22

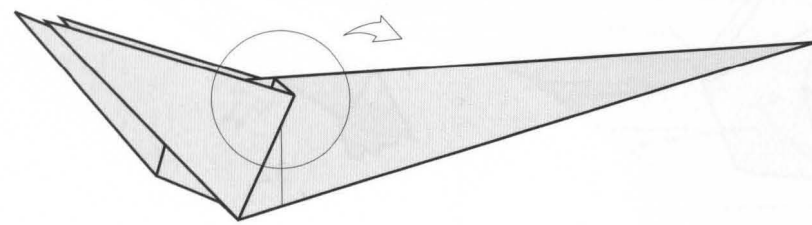

23

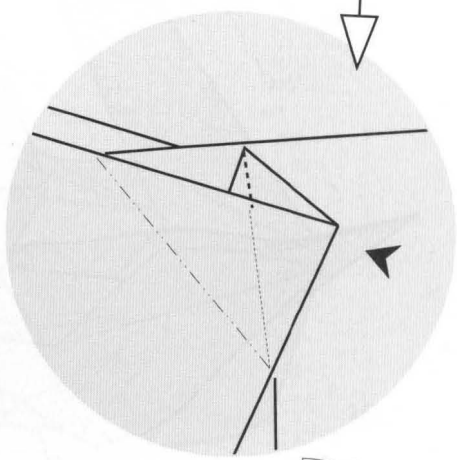

24



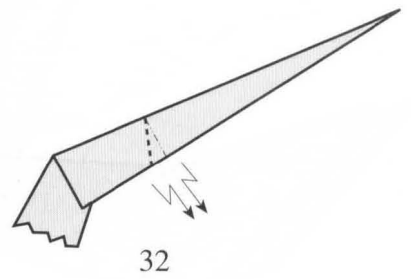
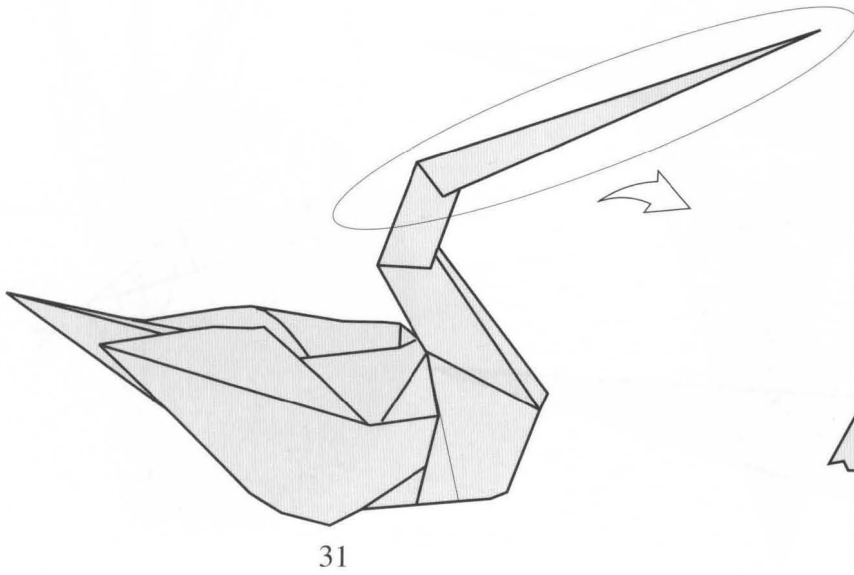
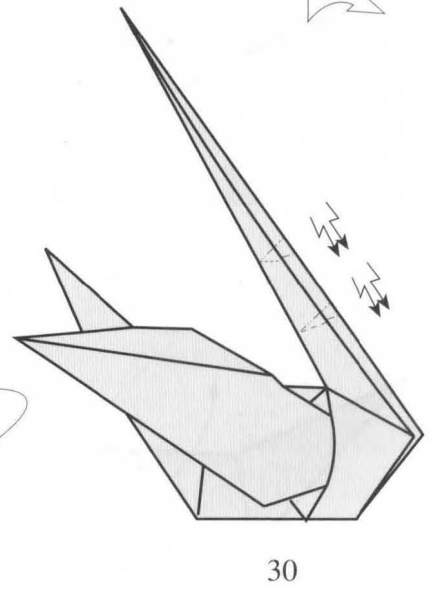
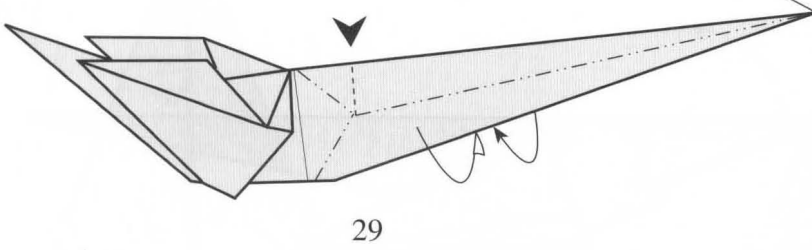
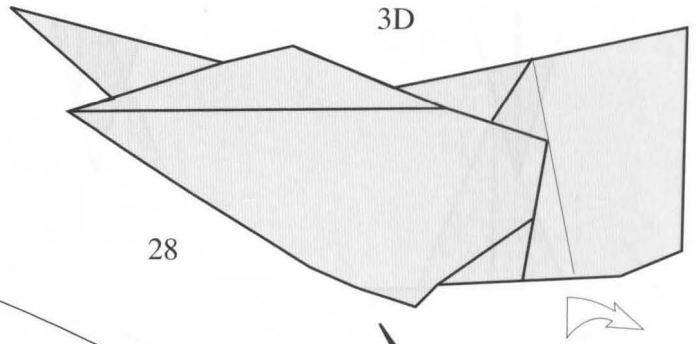
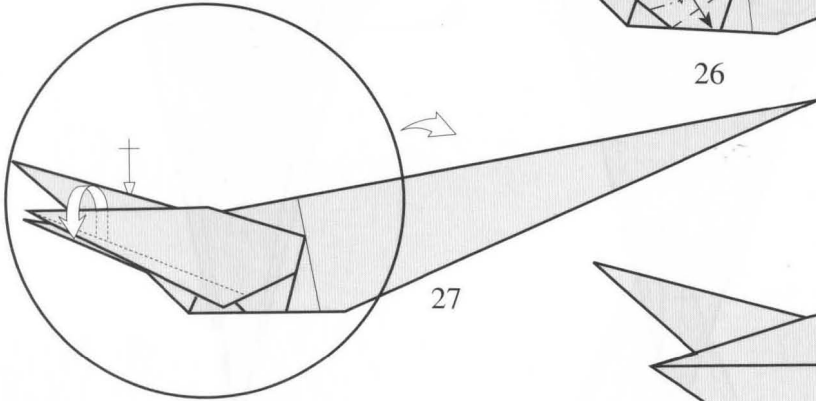
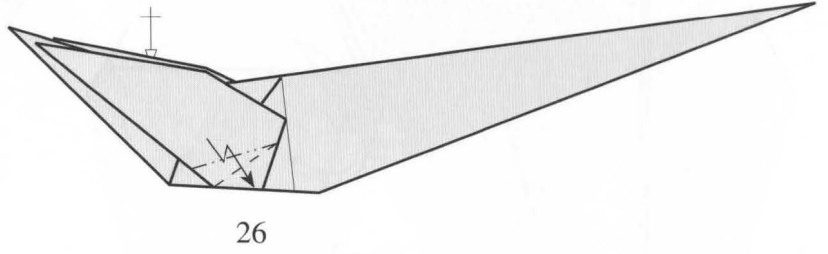
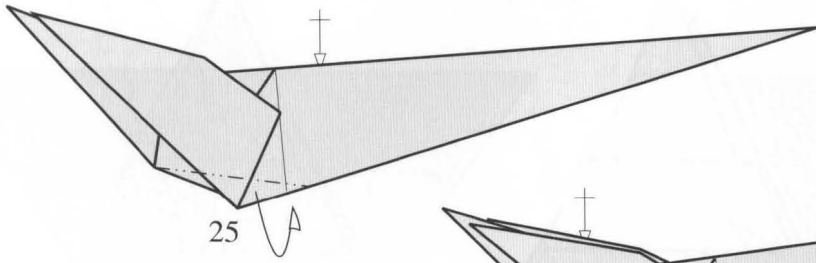

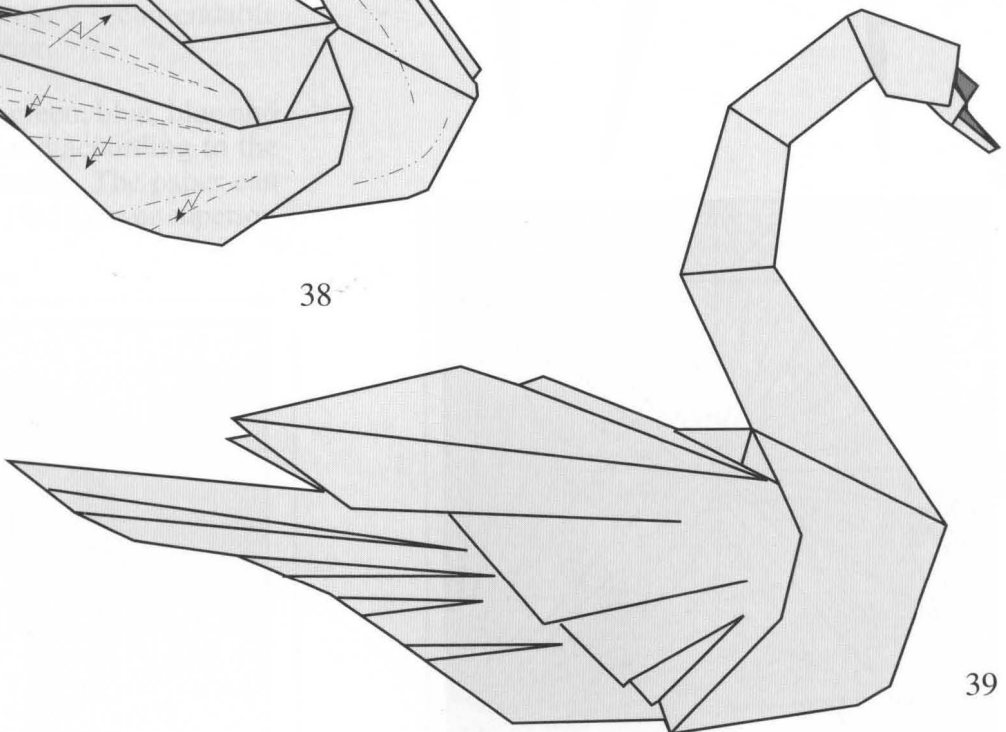
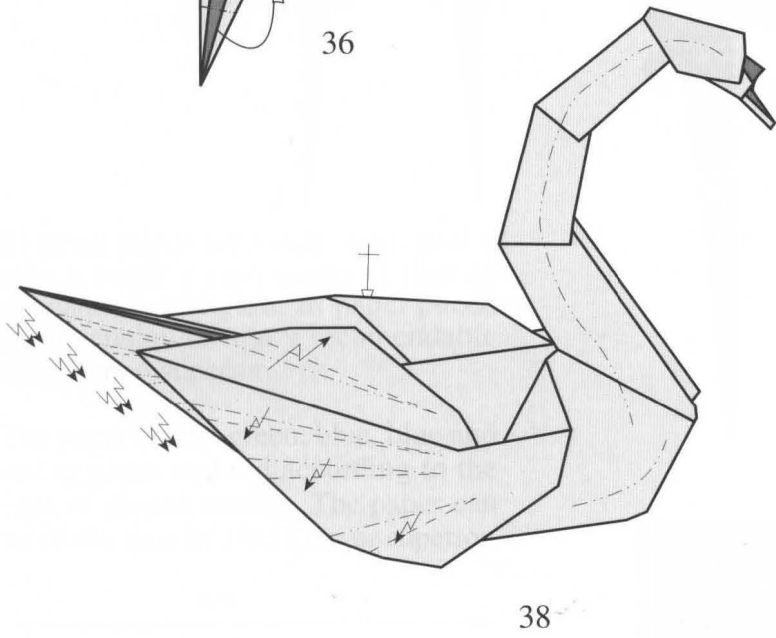
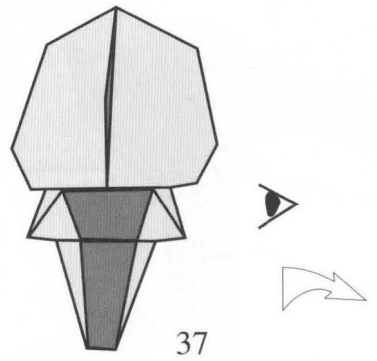
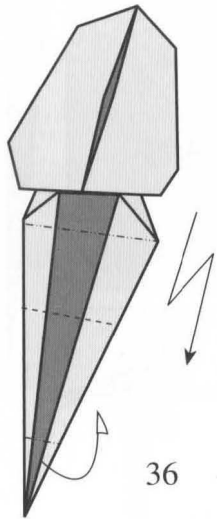
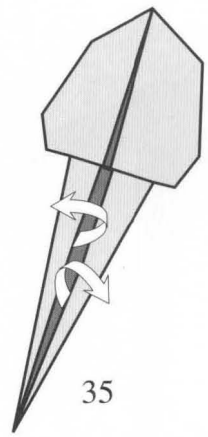
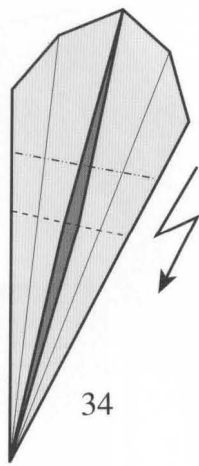
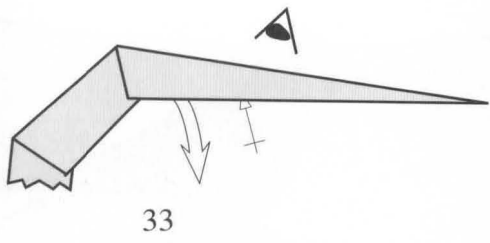

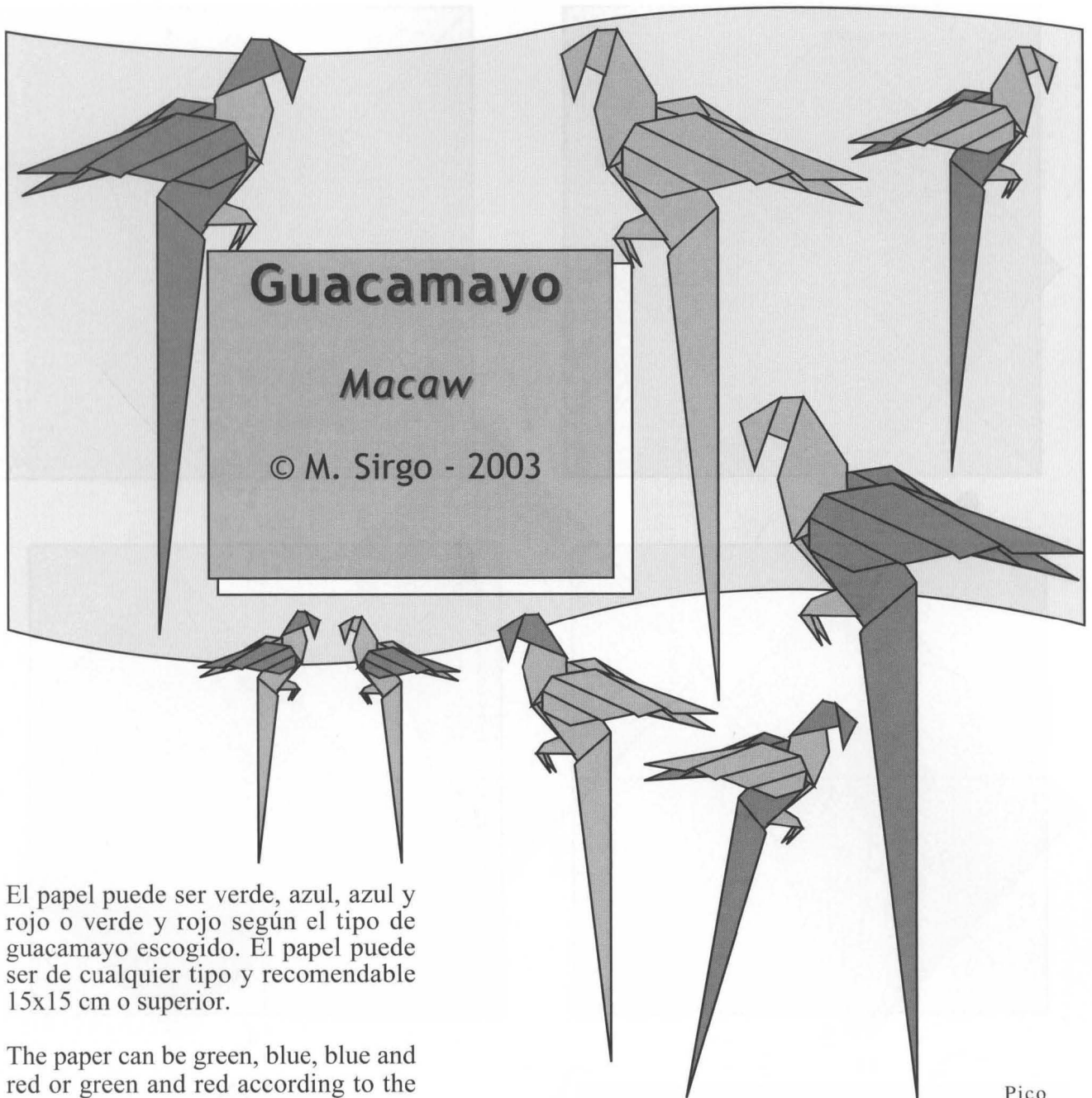

El papel puede ser verde, azul, azul y rojo o verde y rojo según el tipo de guacamayo escogido. El papel puede ser de cualquier tipo y recomendable 15x15 cm o superior.

The paper can be green, blue, blue and red or green and red according to the type of chosen macaw. The paper can be of any type of 15x15 cm or superior.

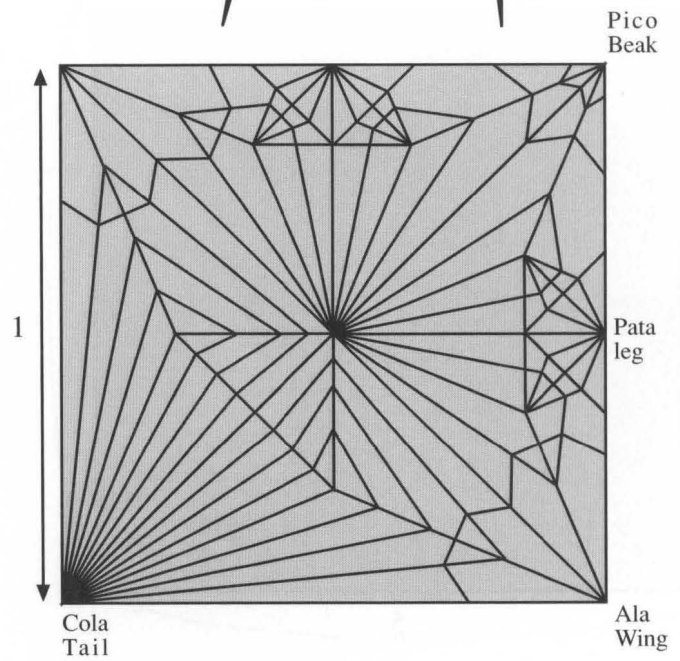
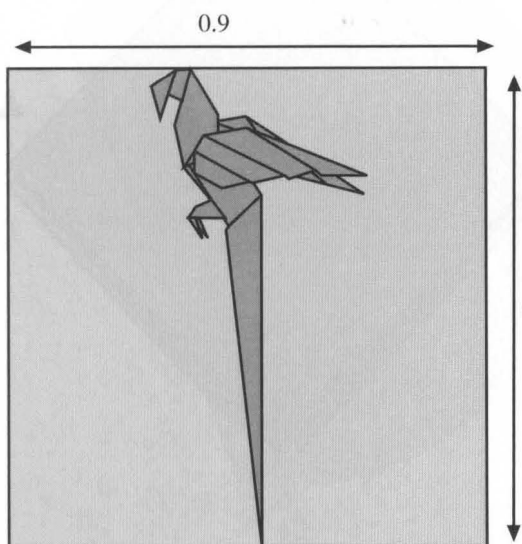

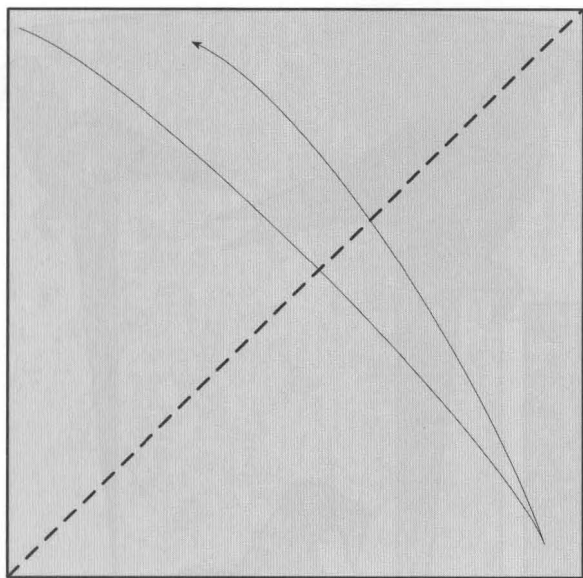

1

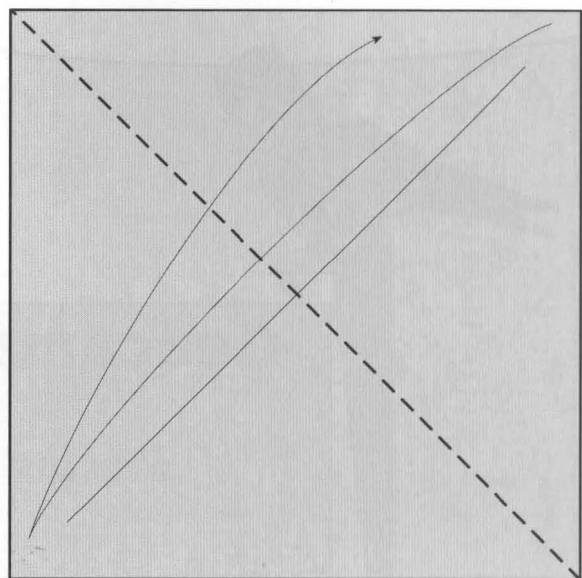

2

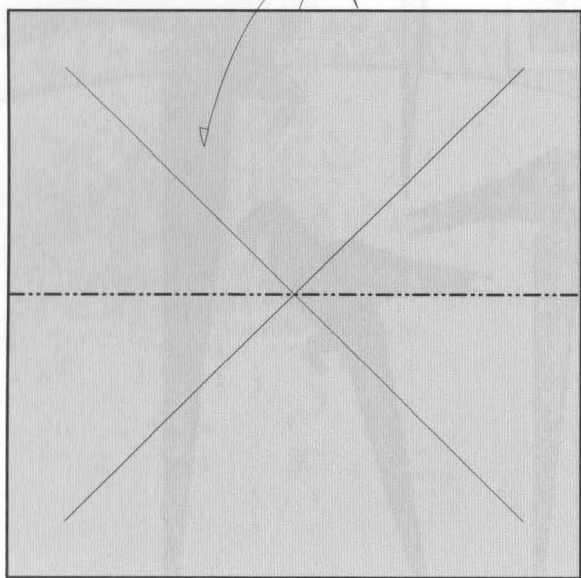

3

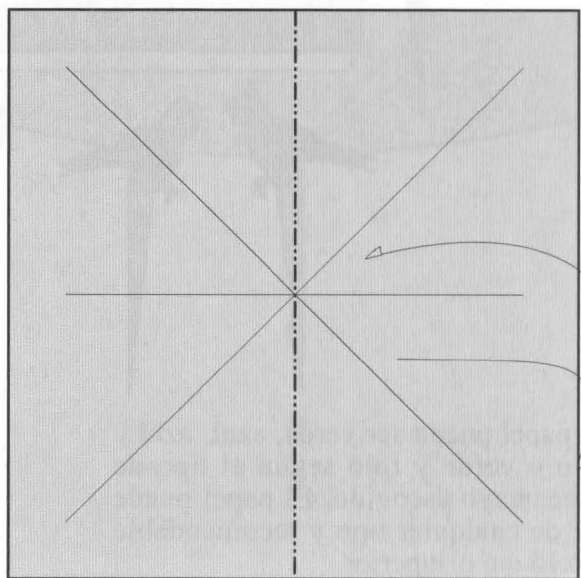

4

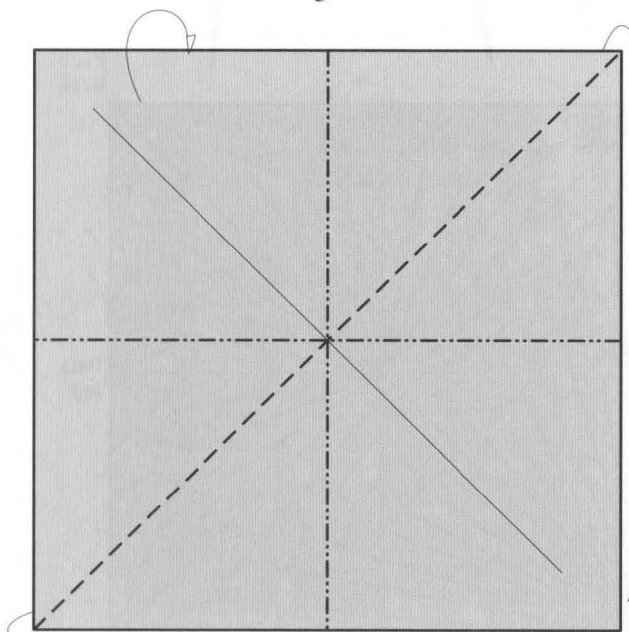

5

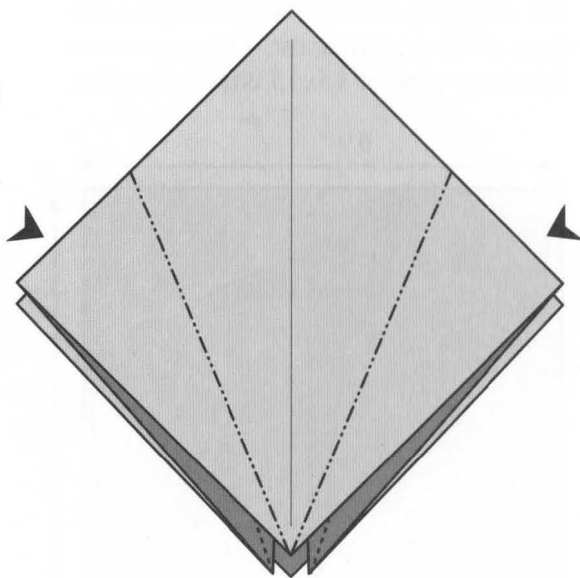

6

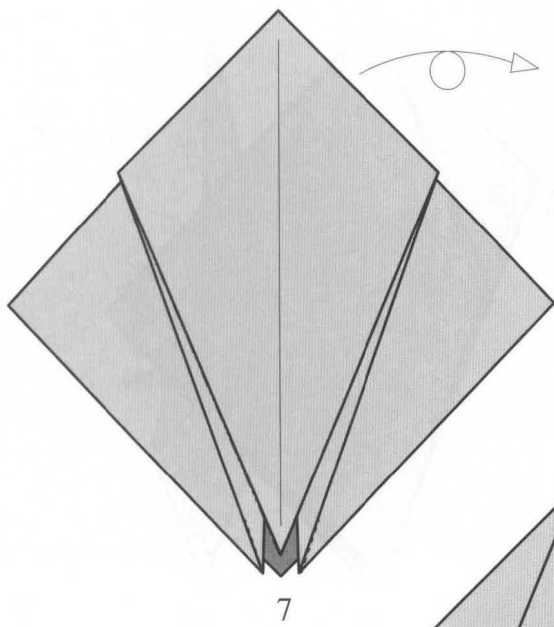

7

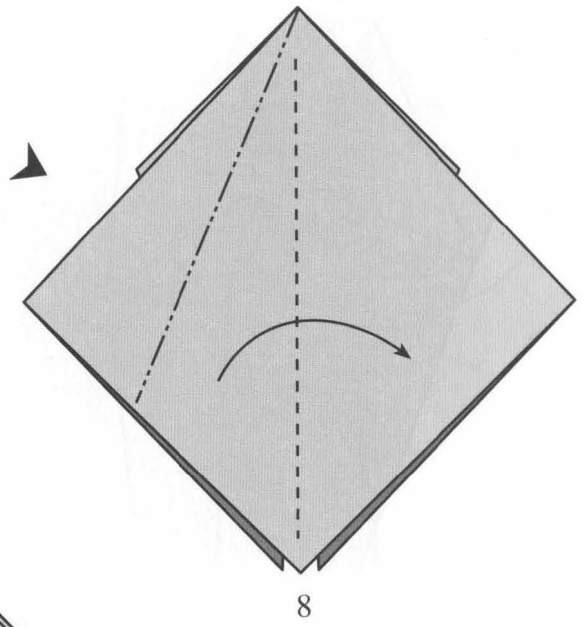

8

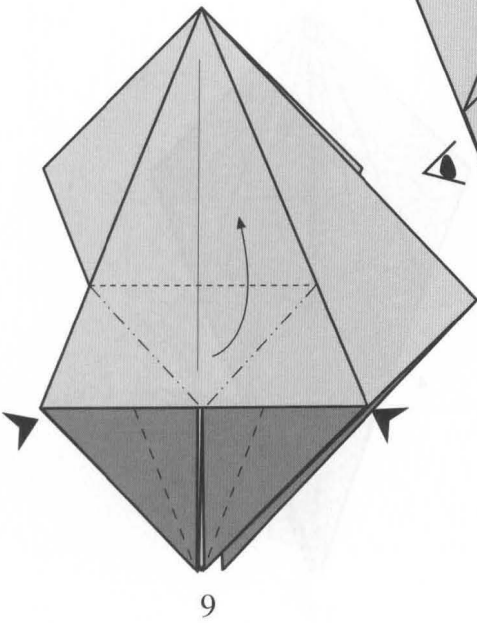

9

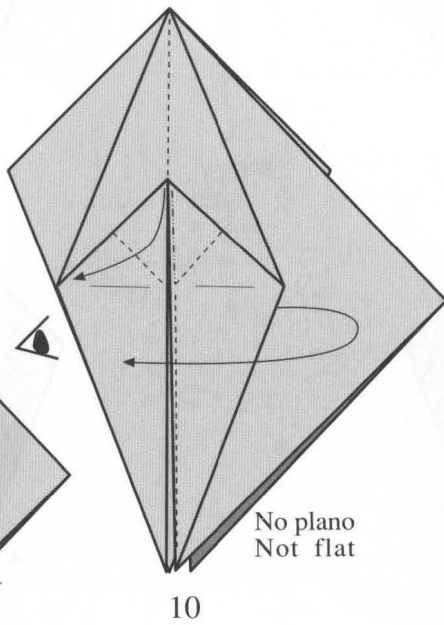

10

No plano
Not flat

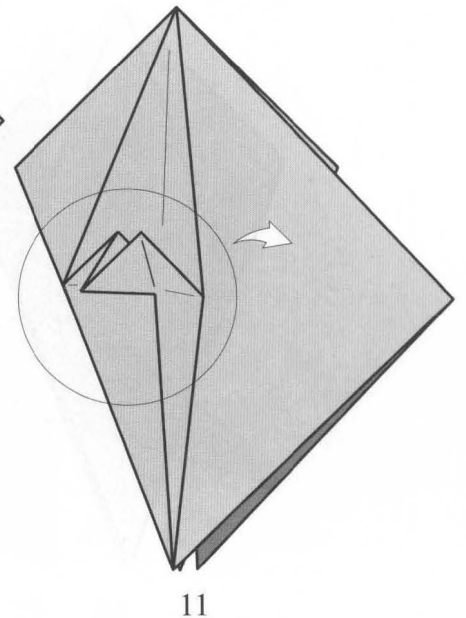

11

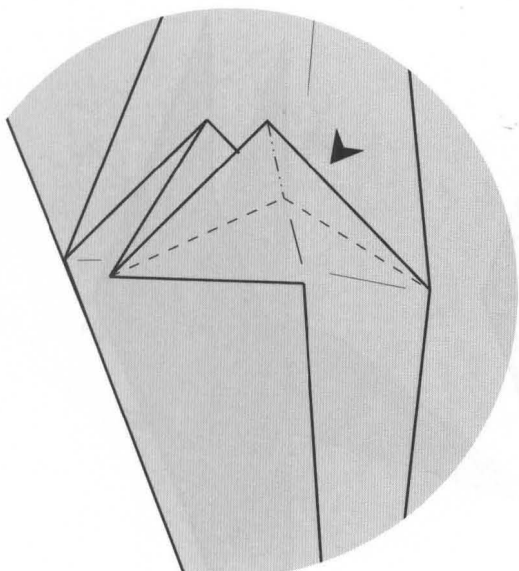

12

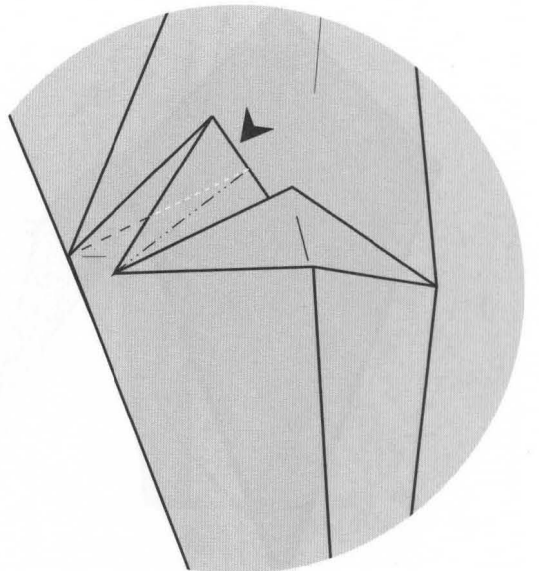

13

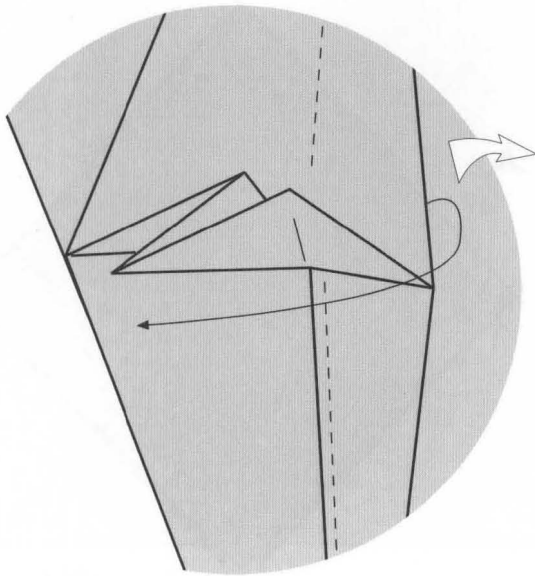

14

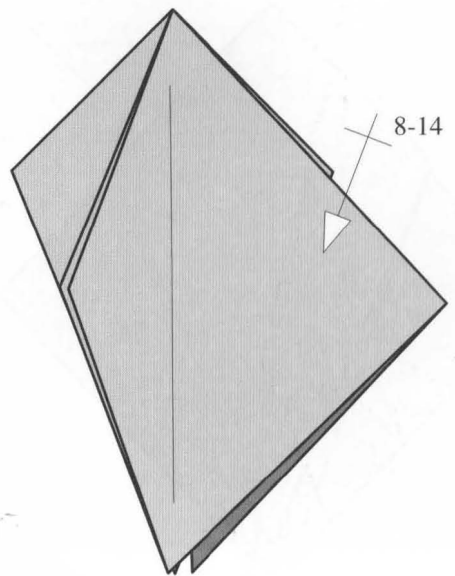

15

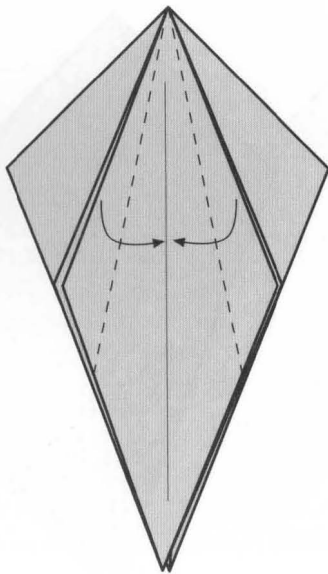

16

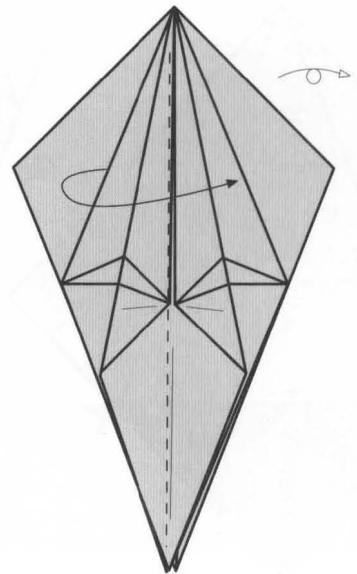

17

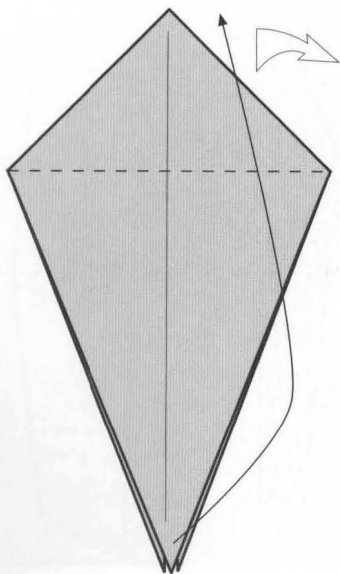

18

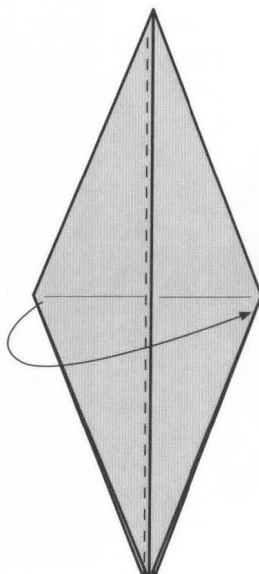

19

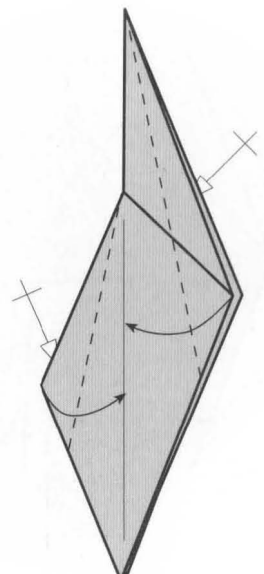

20

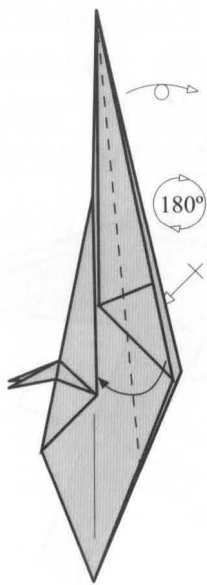

21

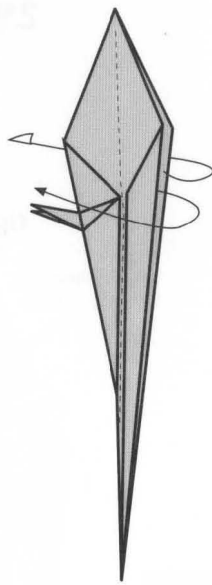

22

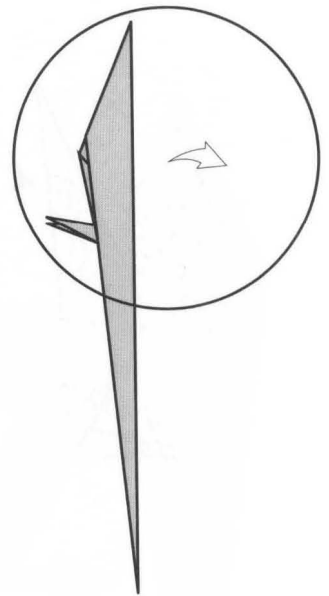

23

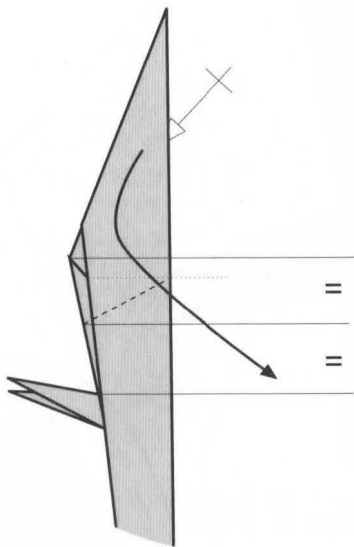

24

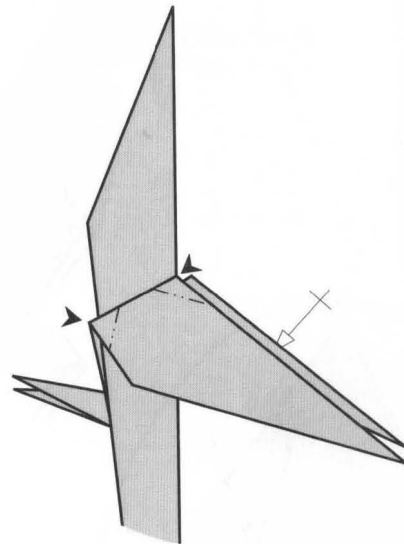

25

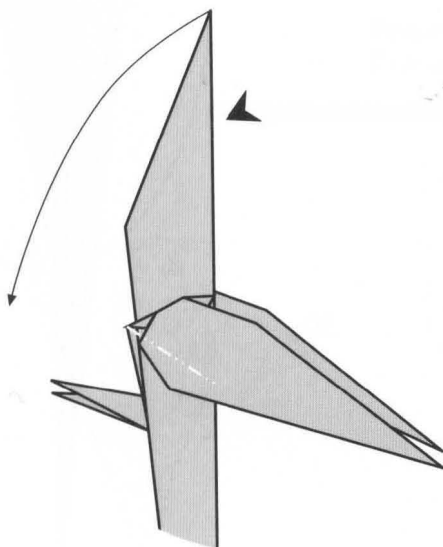

26

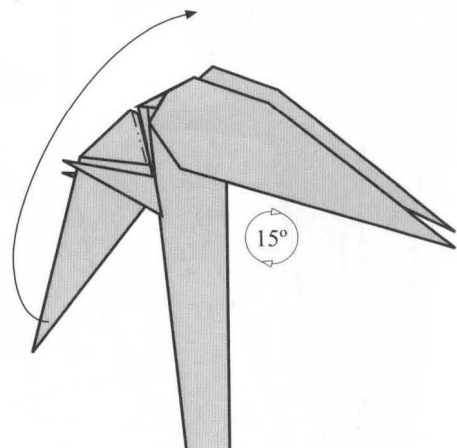

27

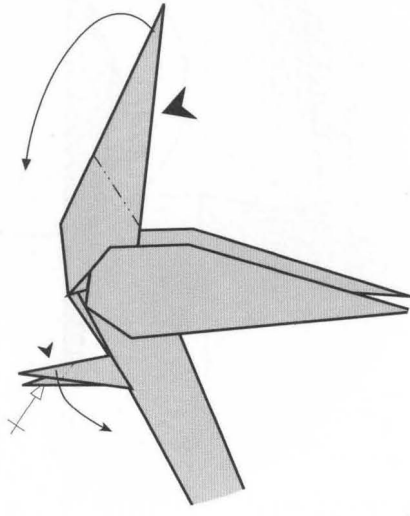

28

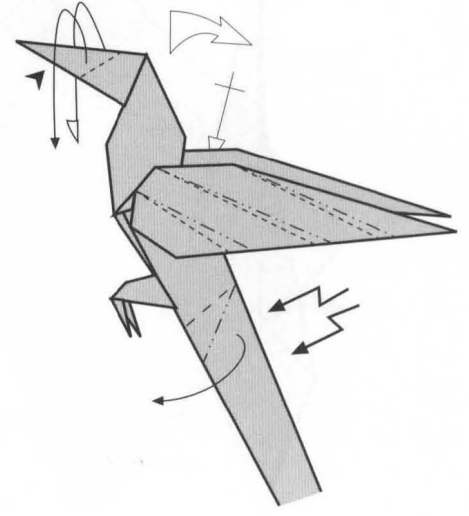

29

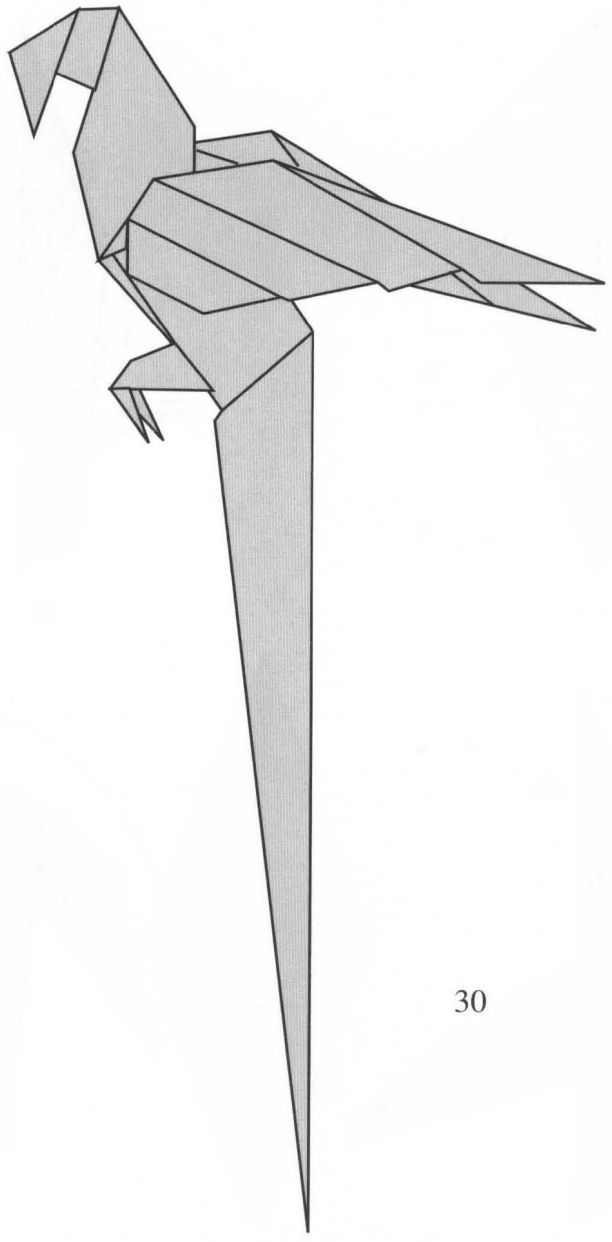

30

Guacamayos bicolores
Variantes diversas
Bicolor macaws
Diverse variants

Estudios de J. C. Borrego y M. Sirgo

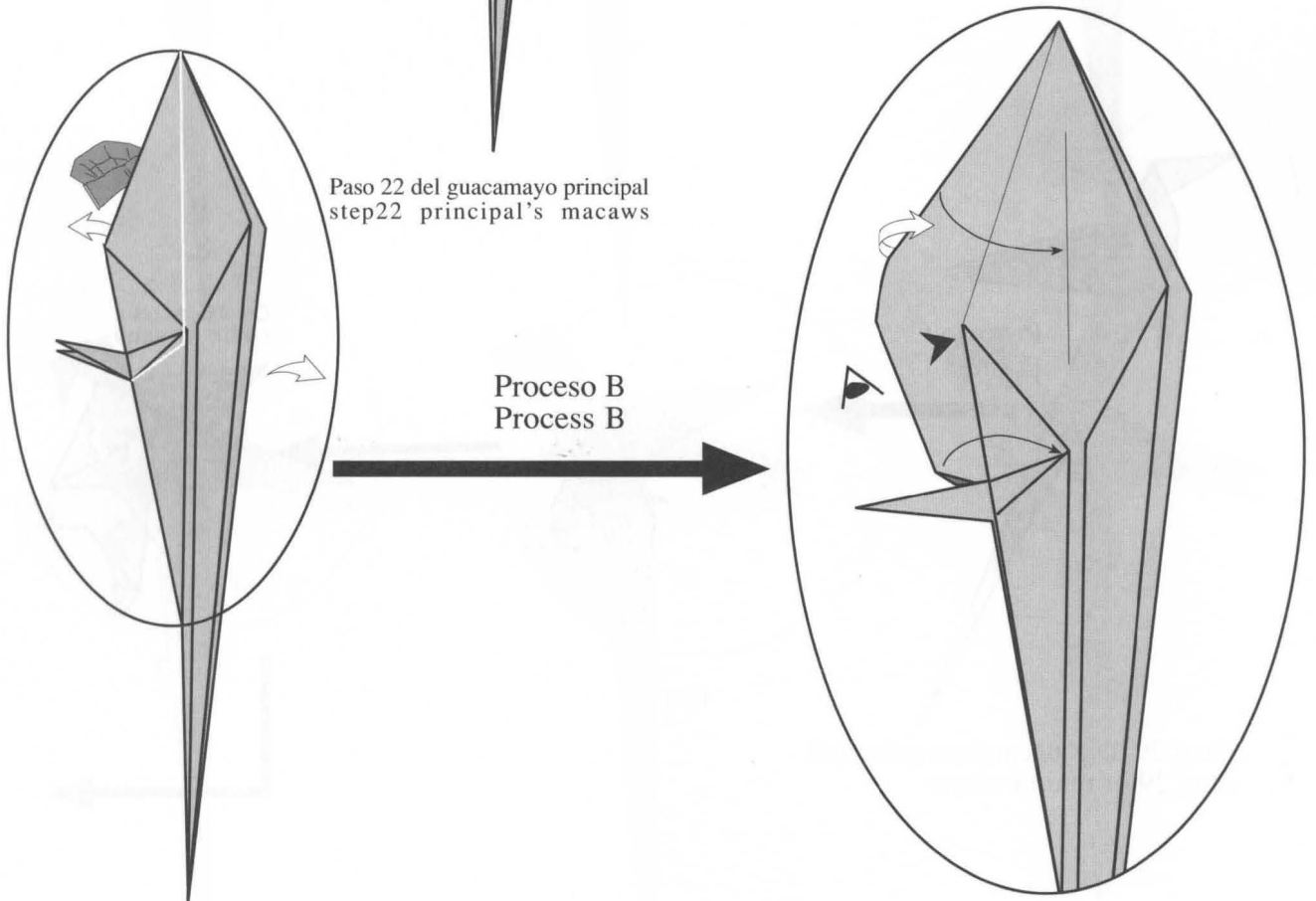
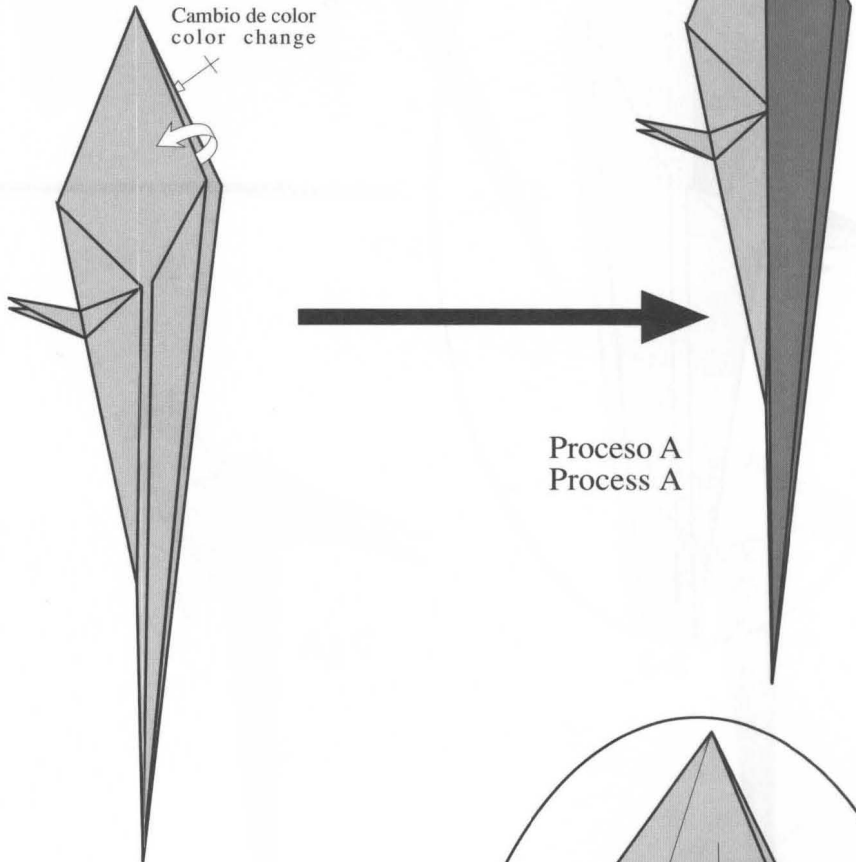

Paso 22 del guacamayo principal
step22 principal's macaws

B-1

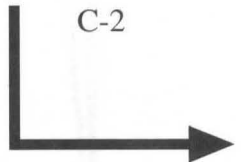
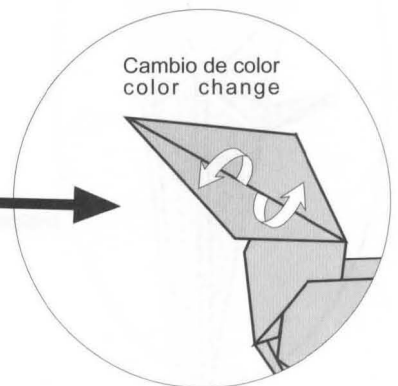
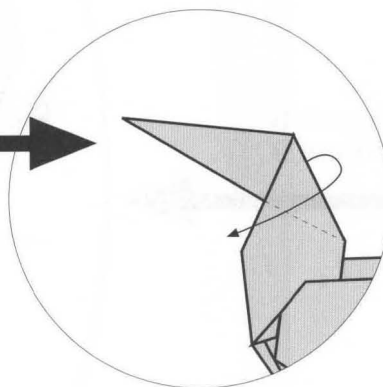
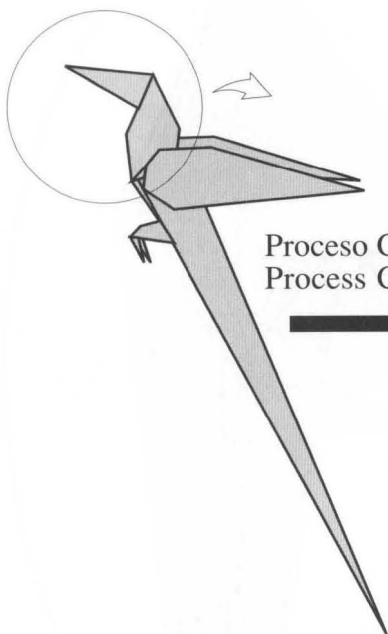
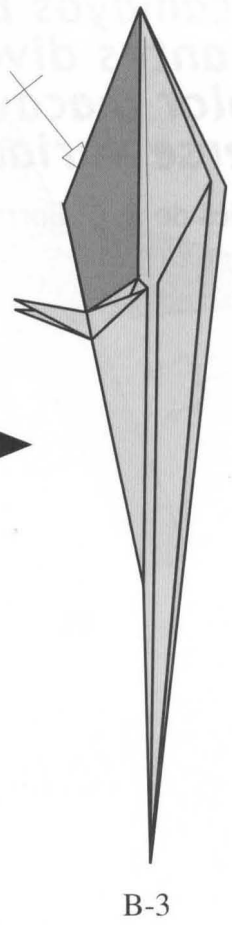
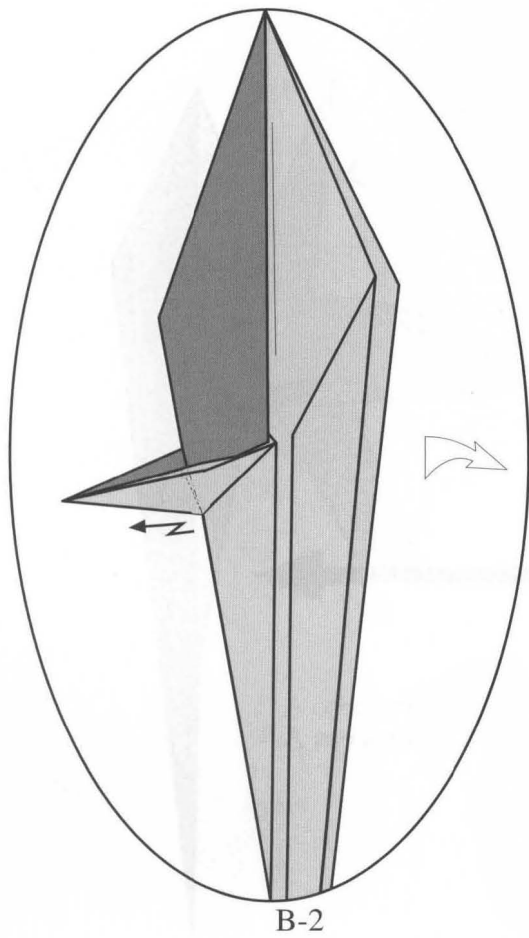

Paso 29 del guacamayo principal
Step 29 of main macaw

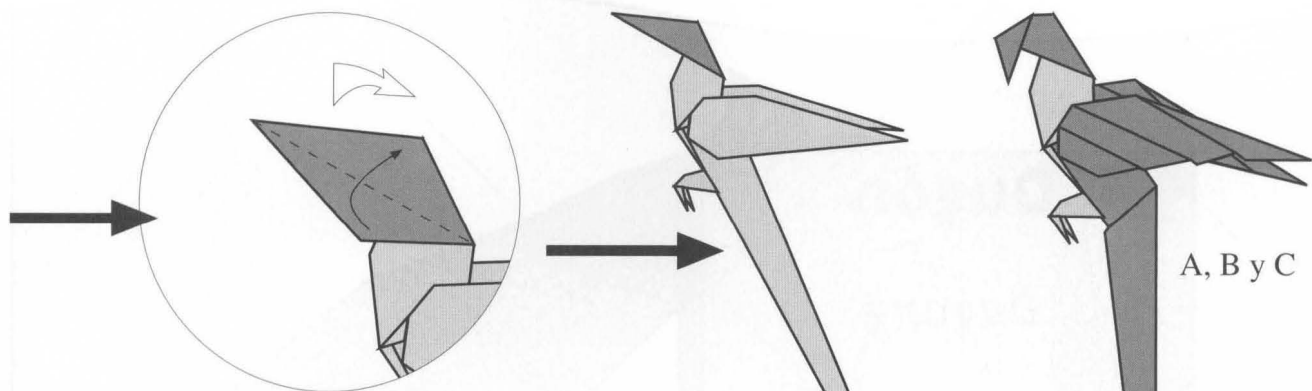

C-3

C-4

A, B y C

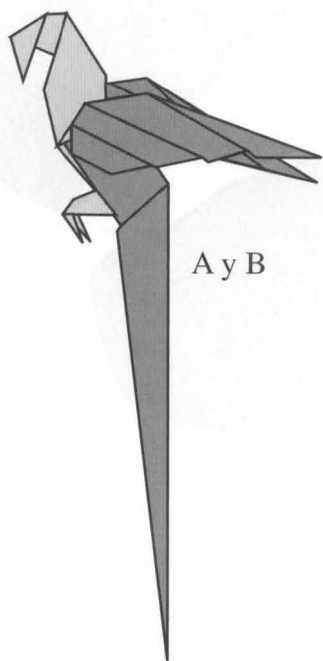

AyB

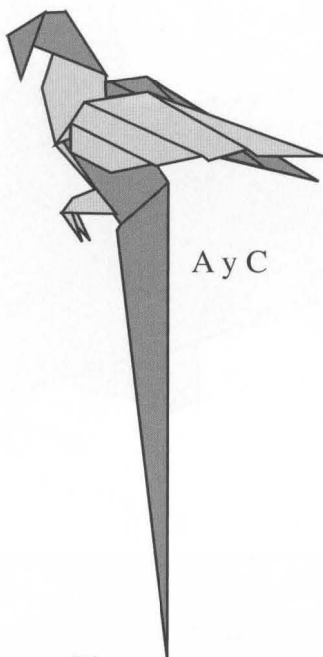

AyC

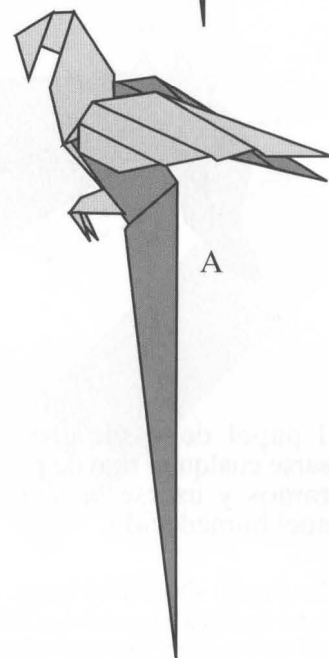

A

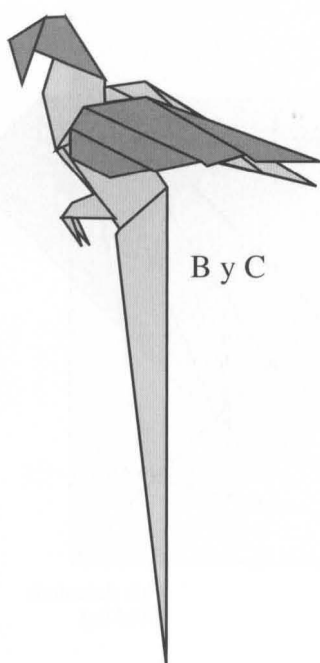

ByC

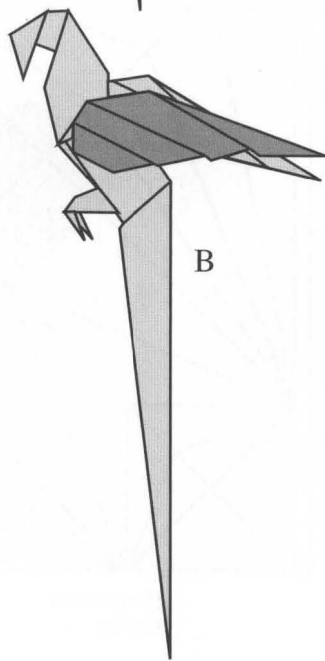

B

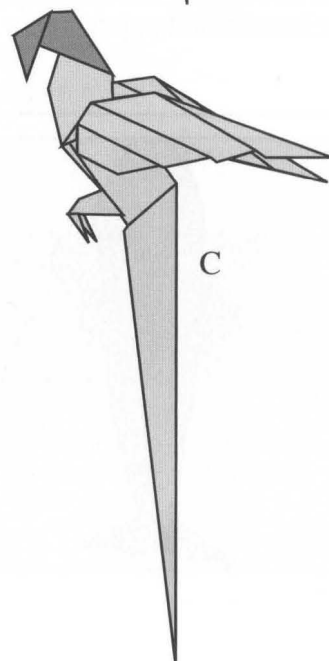

C

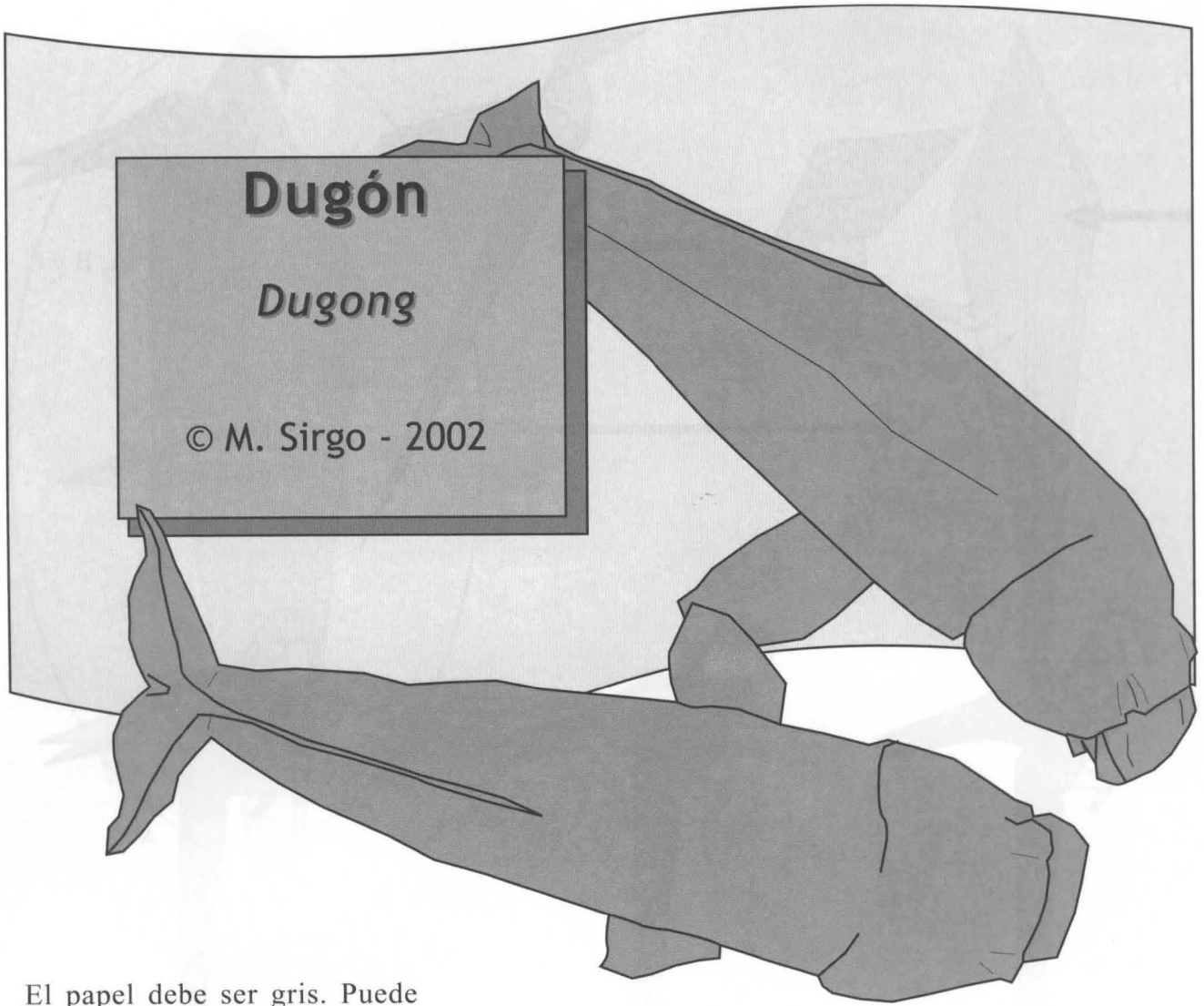

El papel debe ser gris. Puede usarse cualquier tipo de papel, 120 gramos y usarse la técnica del papel humedecido.

The paper should be gray. Any paper type can be used, 120 grams and to be used the technique of the humidified paper.

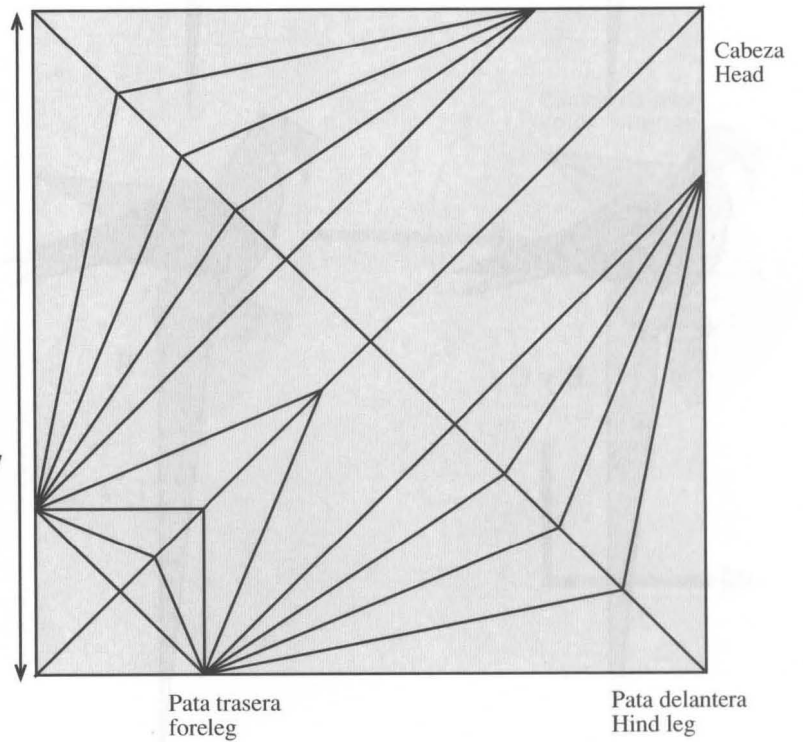
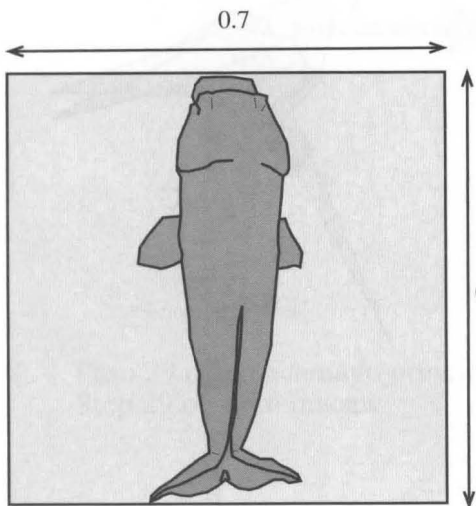

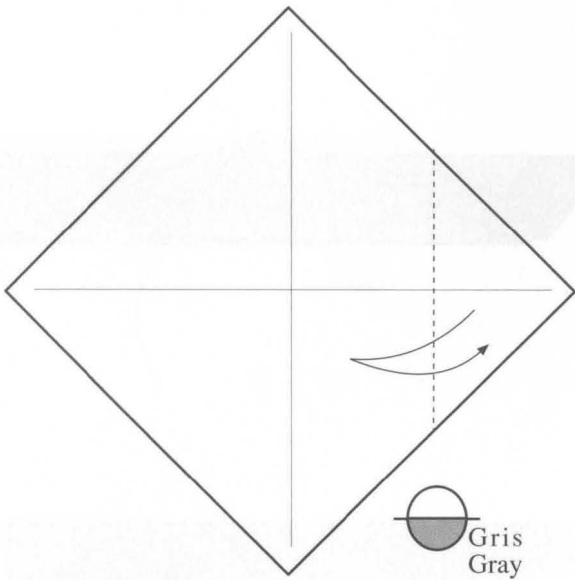

1

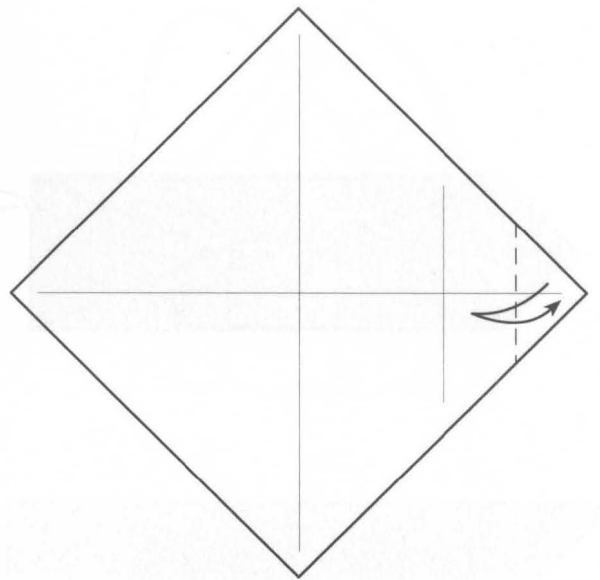

2

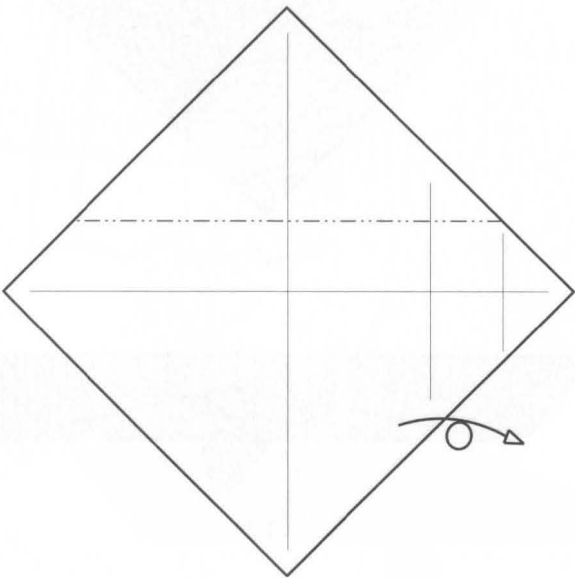

3

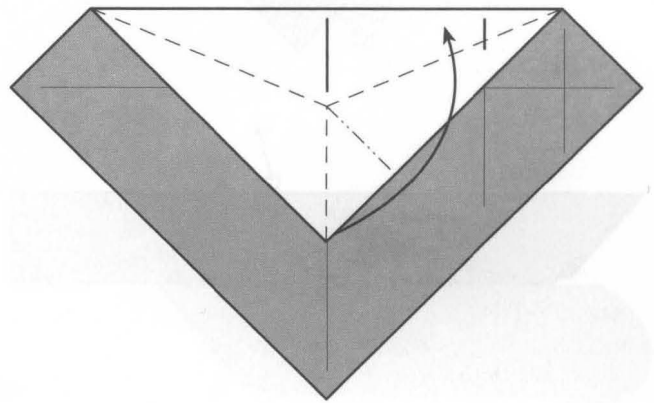

4

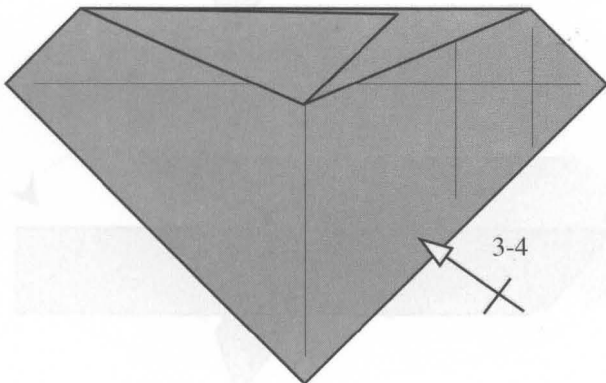

5

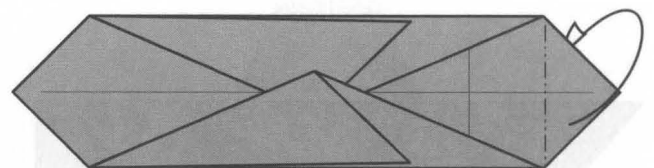

6

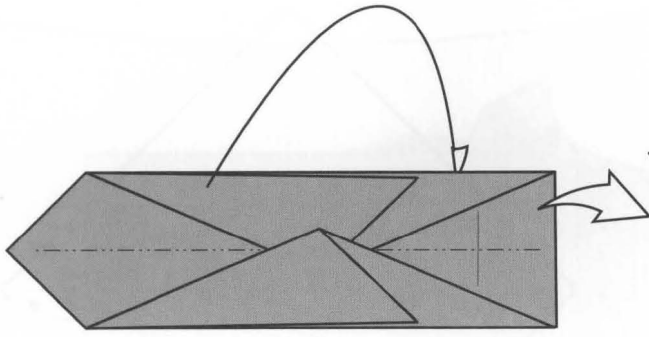

7

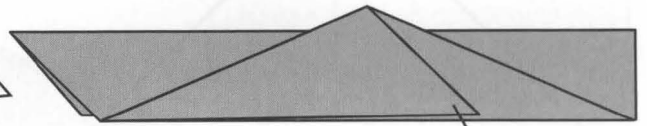

8

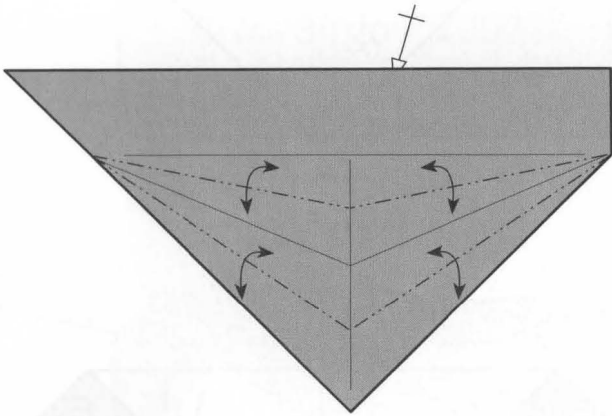

9

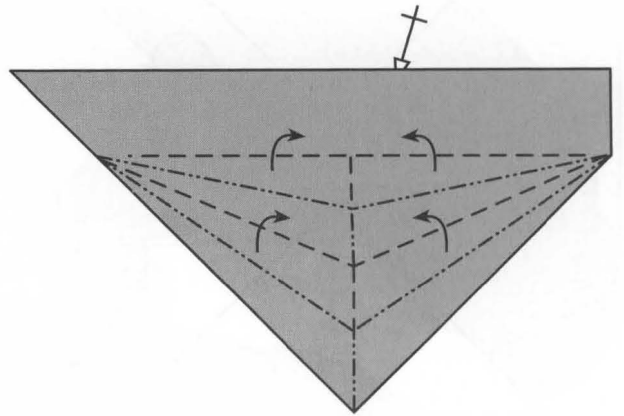

10

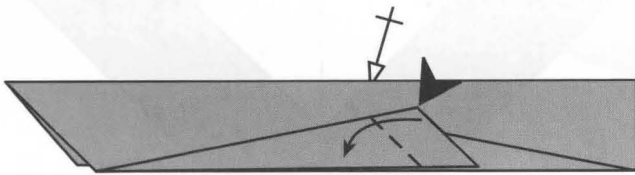

11

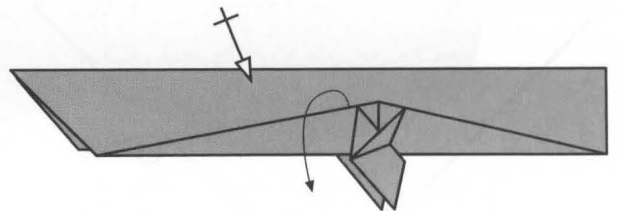

12

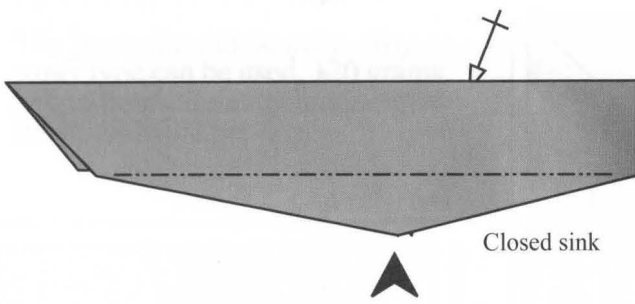

Closed sink

13

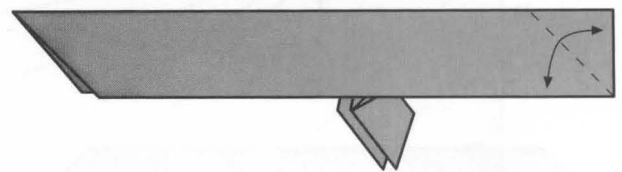

14

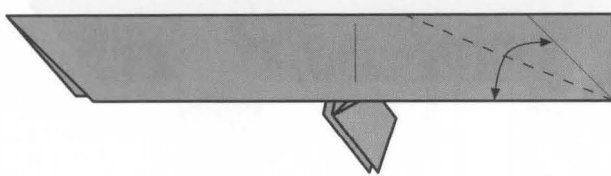

15

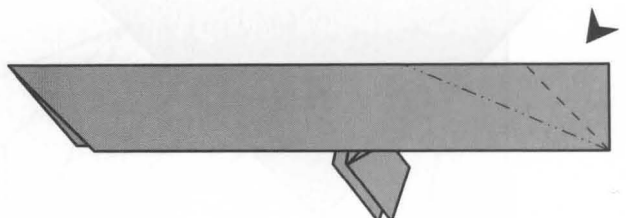

16

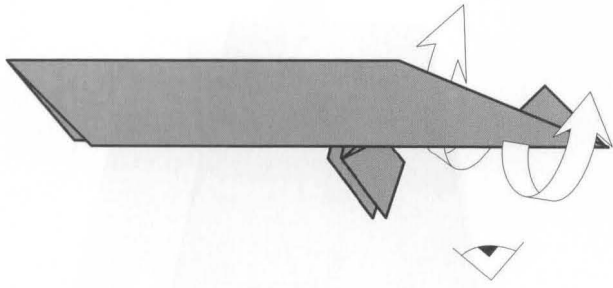

17

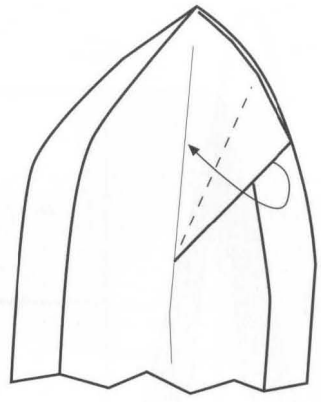

18

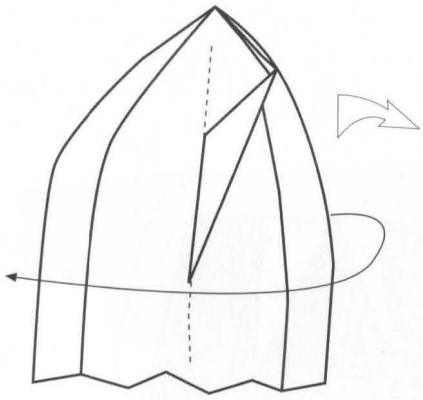

19

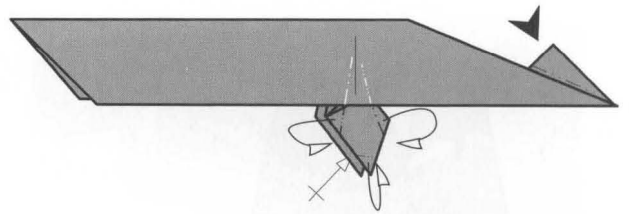

20

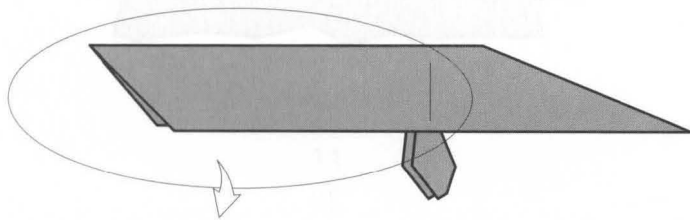

21

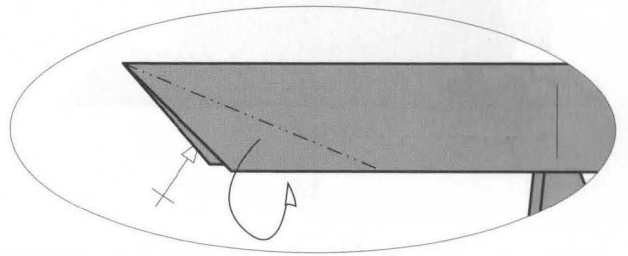

22

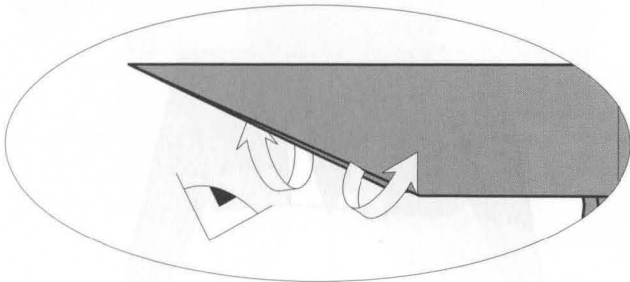

23

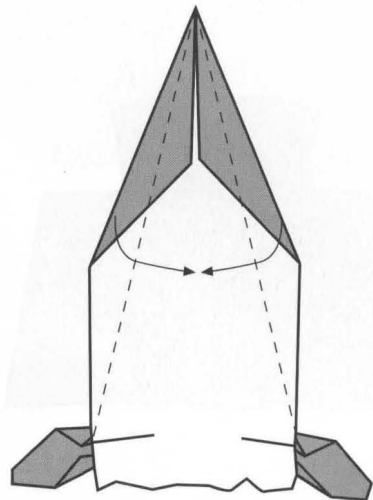

24

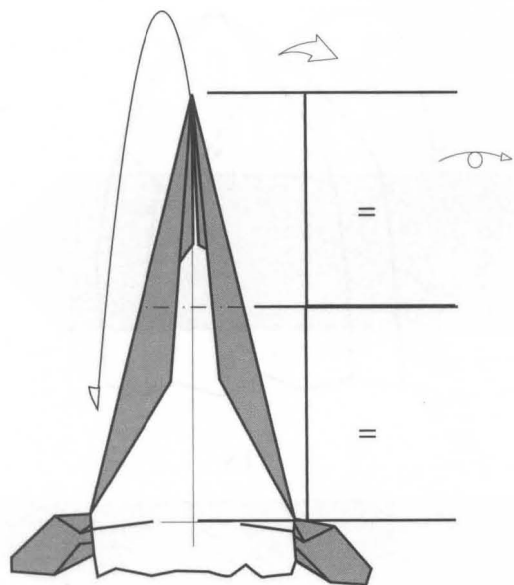

25

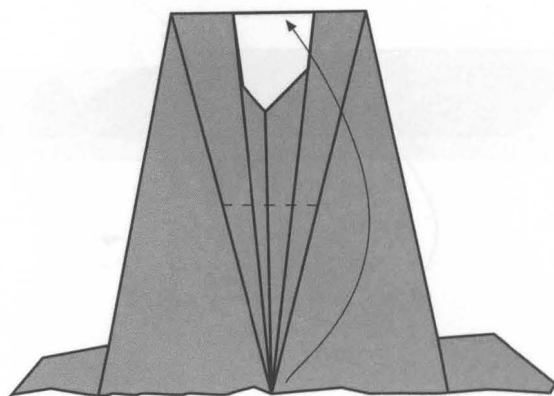

26

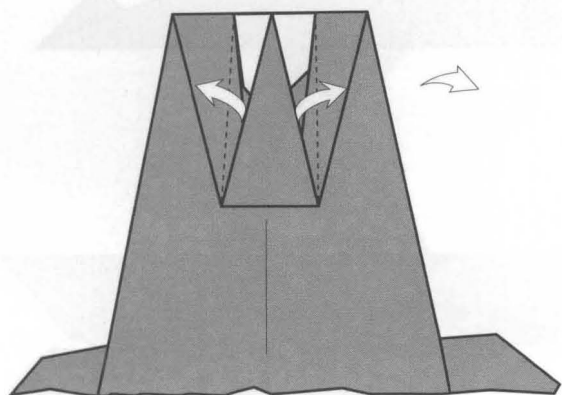

27

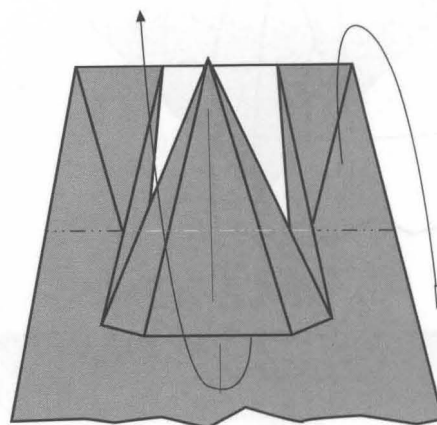

28

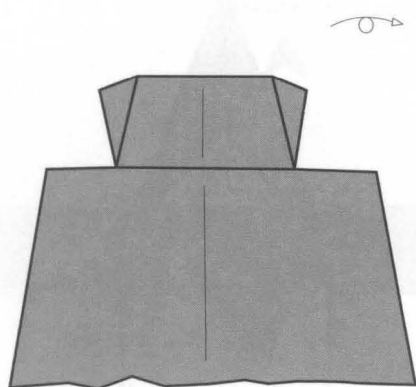

29

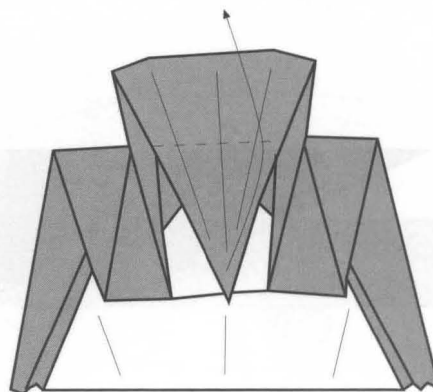

30

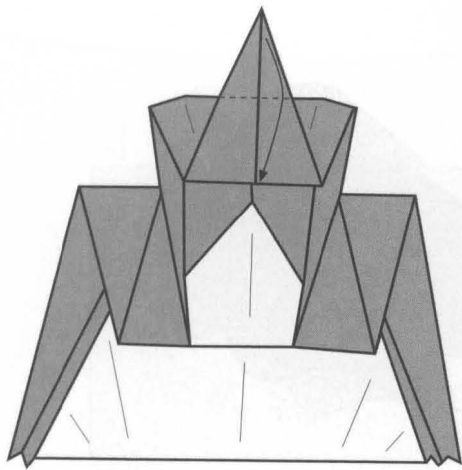

31

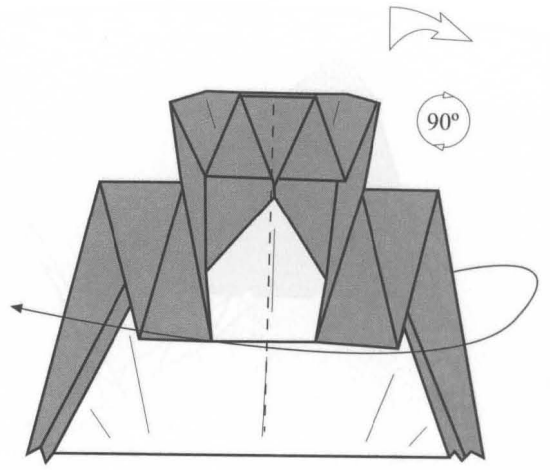

32

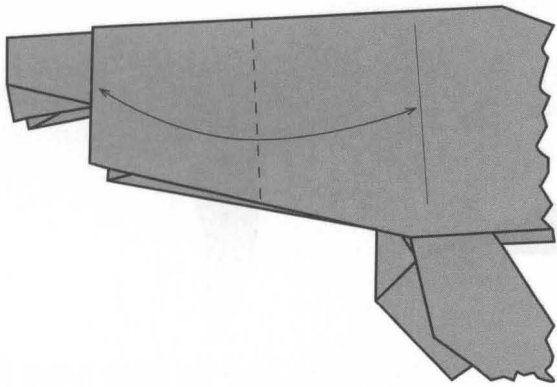

33

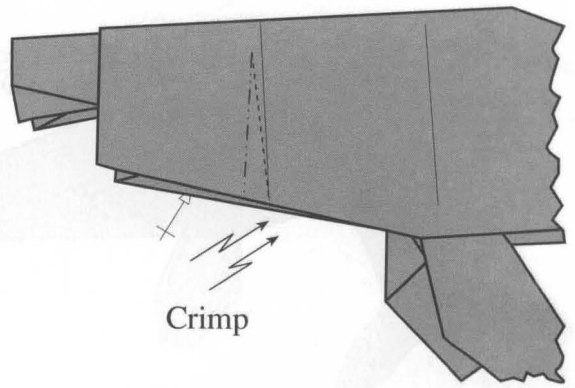

34

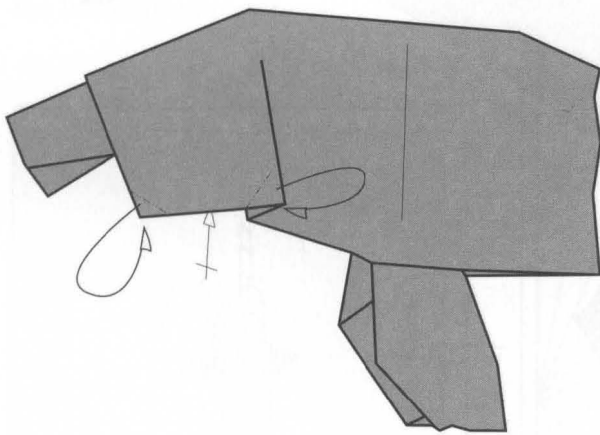

35

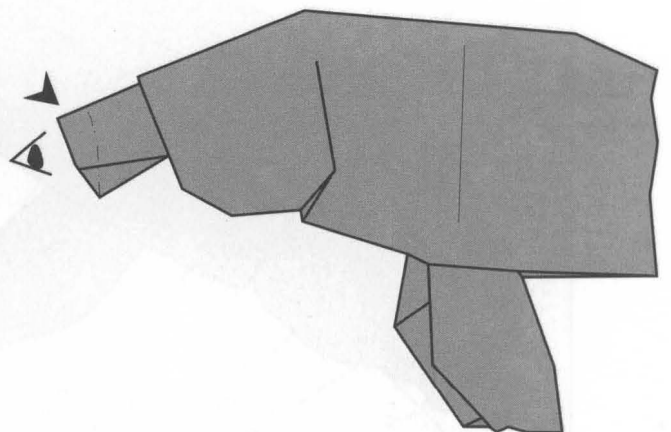

36

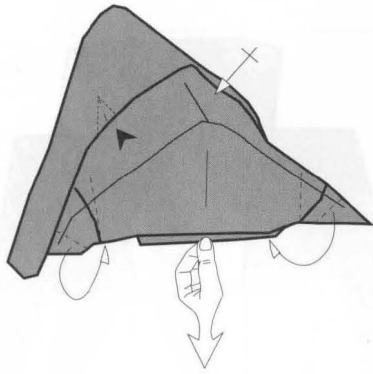

37

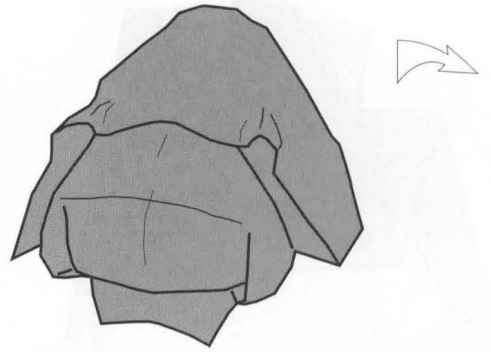

38

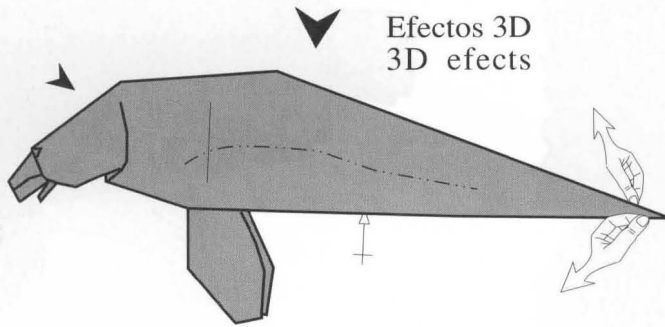

39

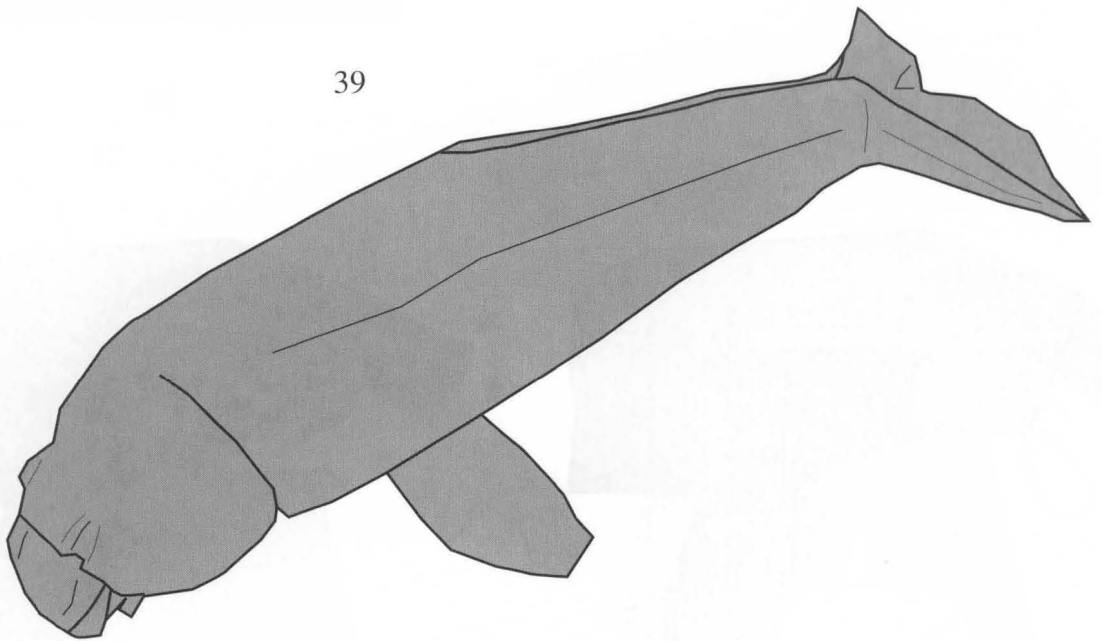

40

42

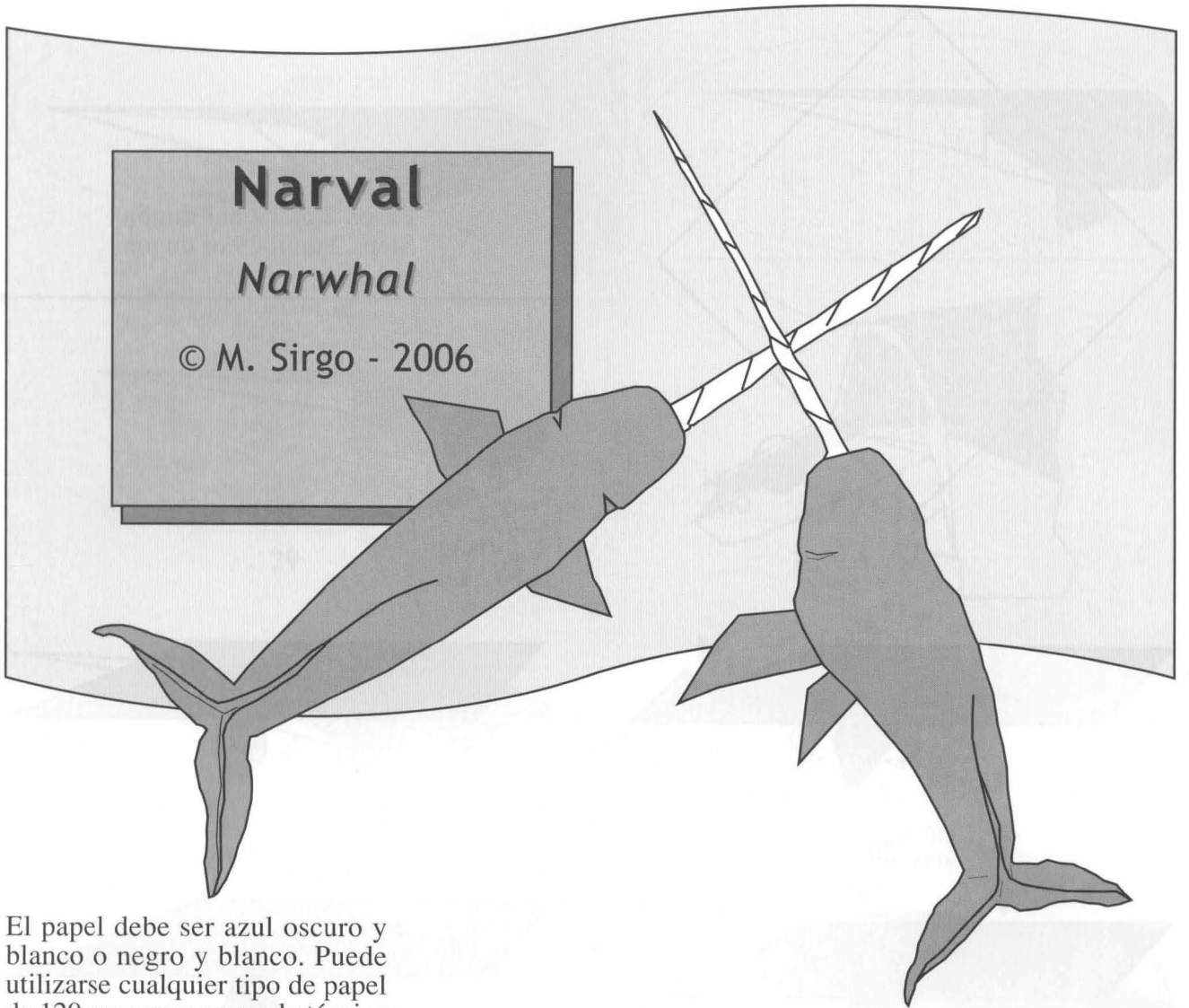

El papel debe ser azul oscuro y blanco o negro y blanco. Puede utilizarse cualquier tipo de papel de 120 gramos y usarse la técnica del papel humedecido.

The paper should be dark blue and white or black and white. Any paper type can be used, 120 grams and to be used the technique of the humidified paper.

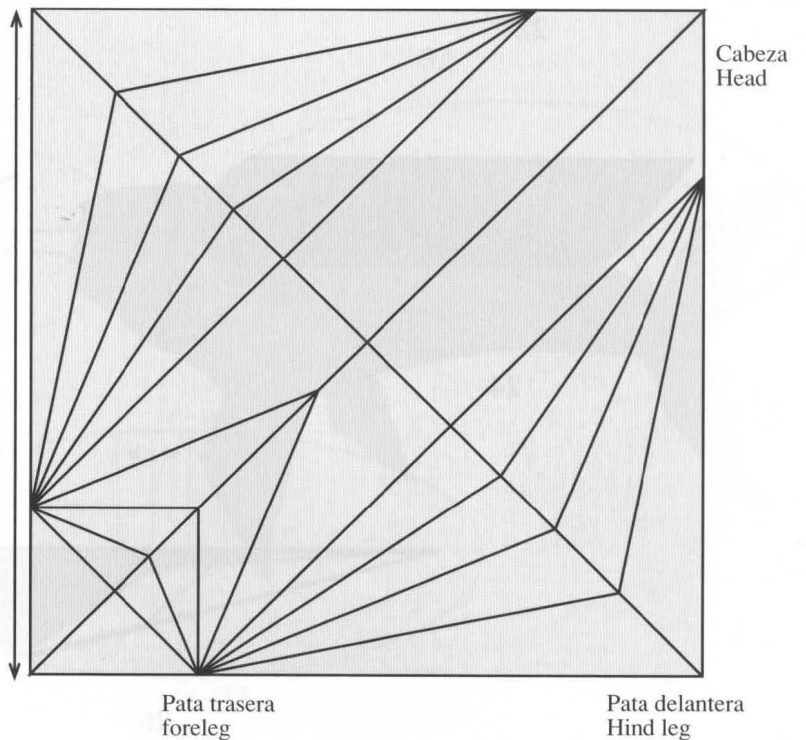
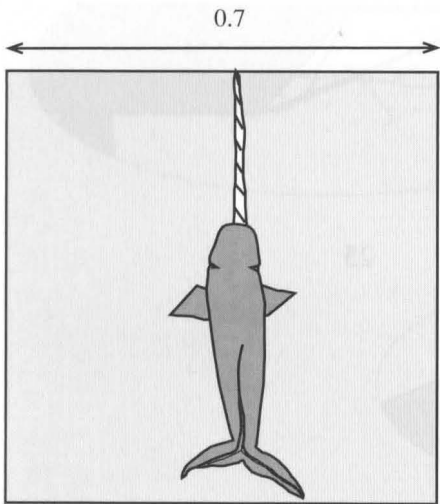

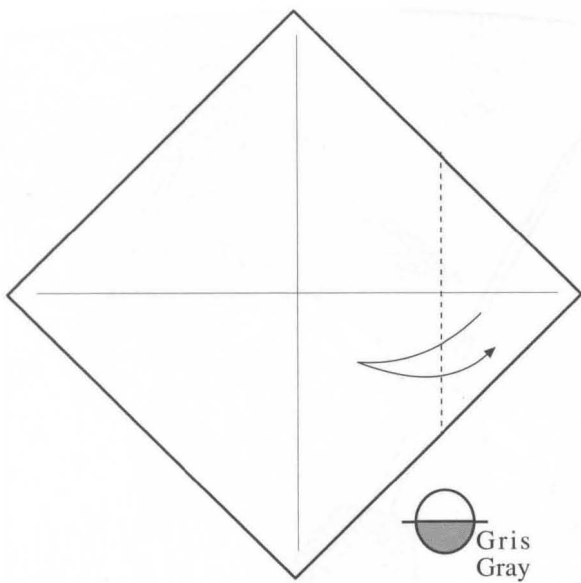

1

Pasos 2 al 19 del dugón
Steps 2 until 19 of dugon

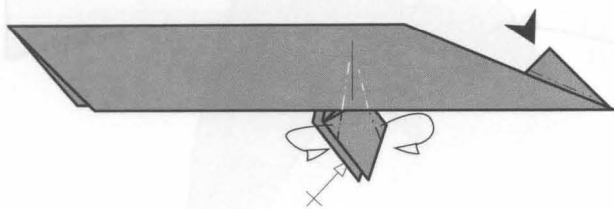

20

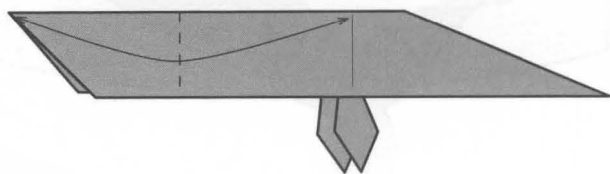

21

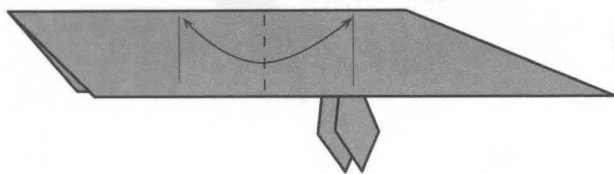

22

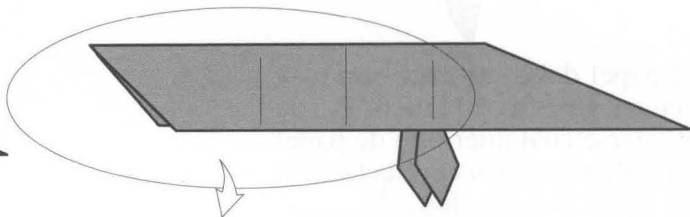

23

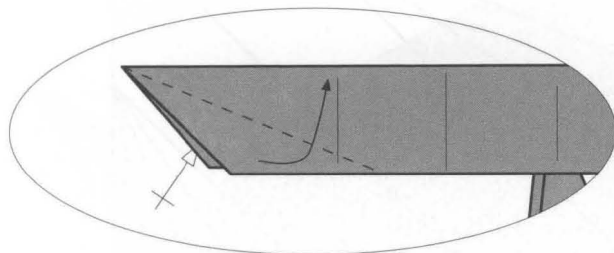

24

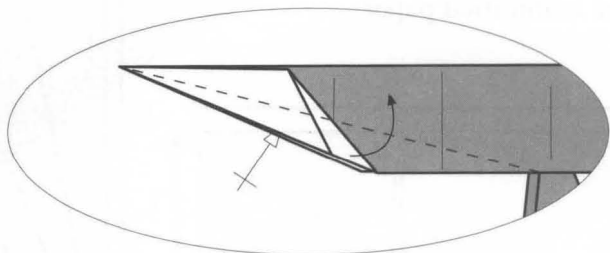

25

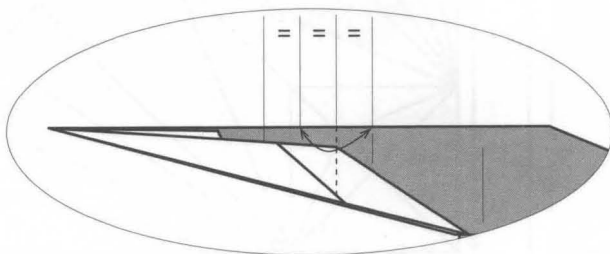

26

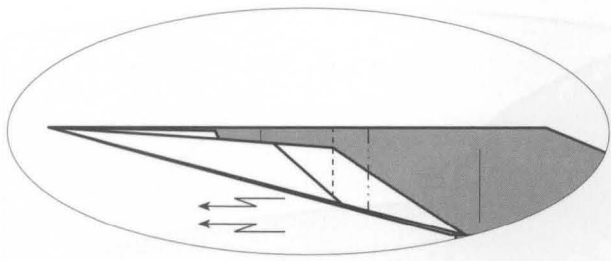

27

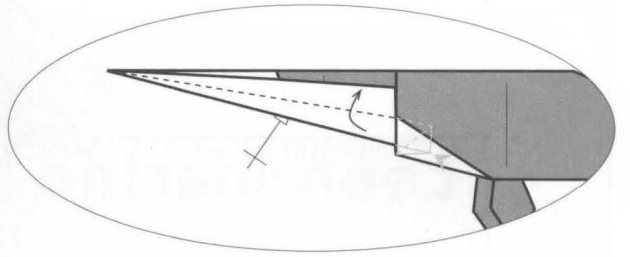

28

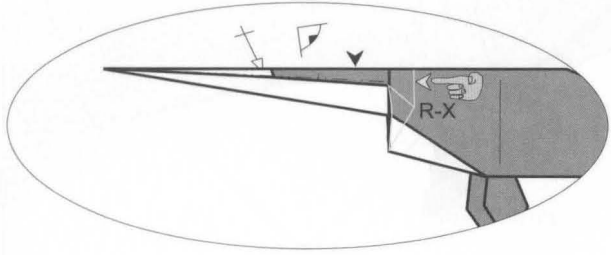

29

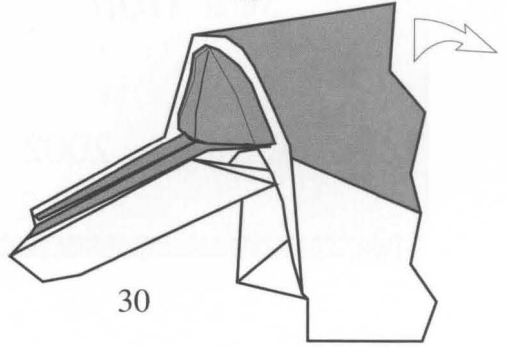

30

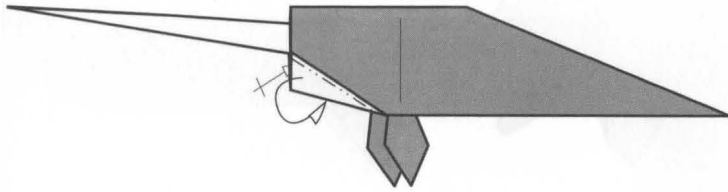

31

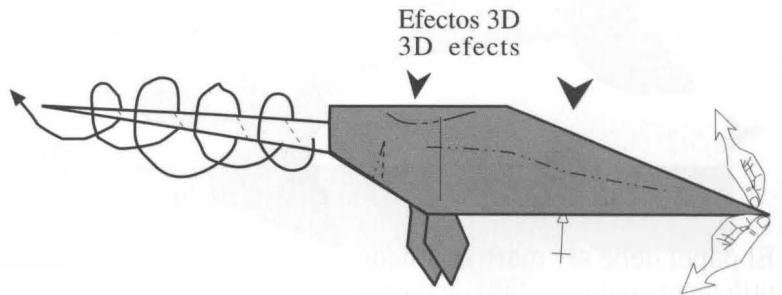

32

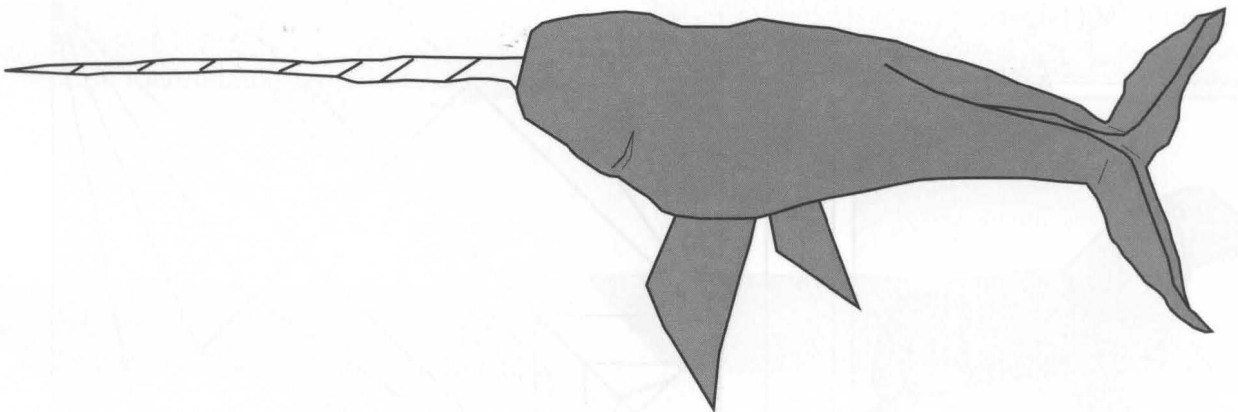

33

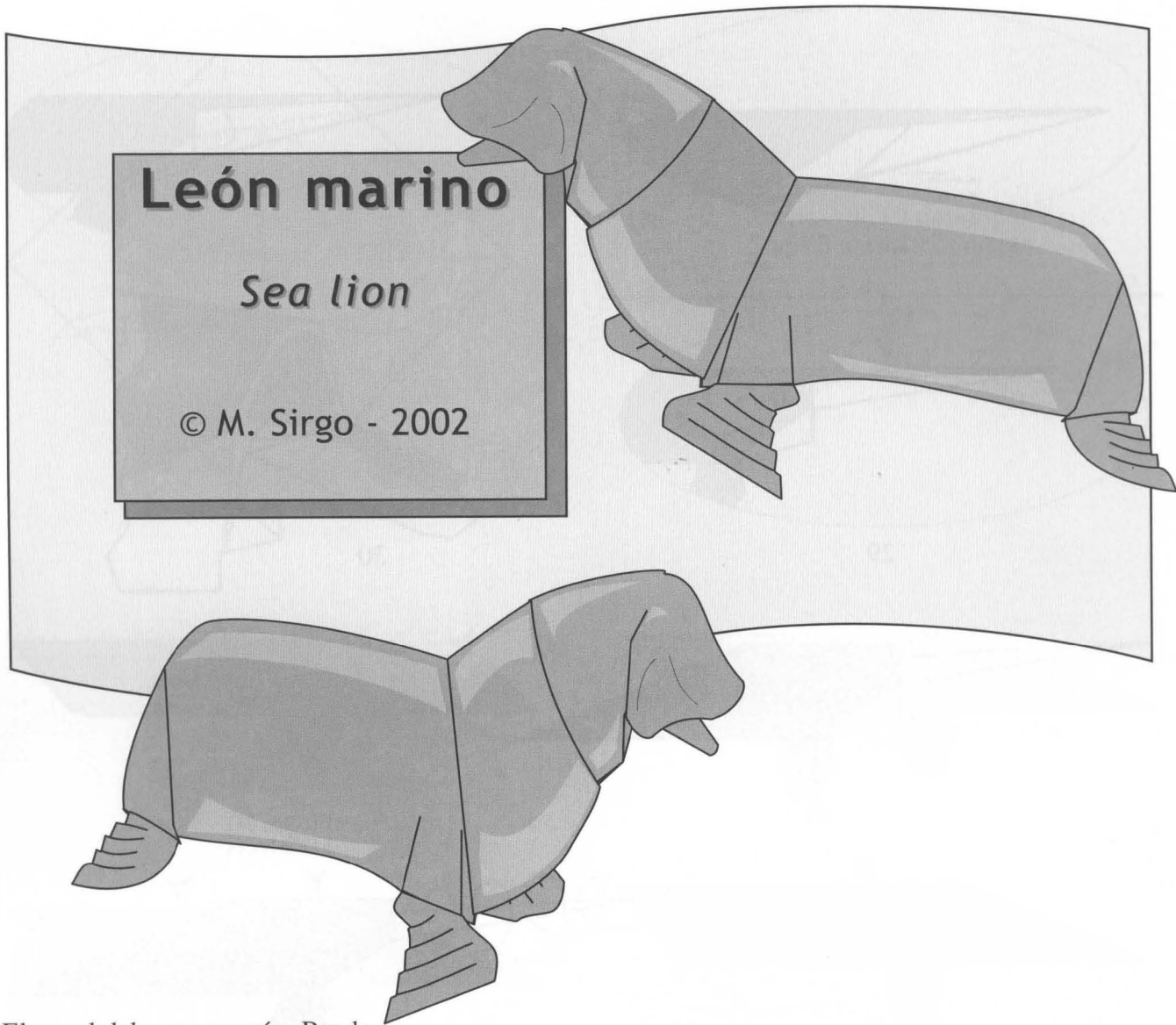

León marino
Sea lion
 © M. Sirgo - 2002

El papel debe ser marrón. Puede utilizarse cualquier tipo de papel, de 120 gramos y usarse la técnica del papel humedecido.
 The paper should be brown. Any paper type can be used, 120 grams and to be used the technique of the humidified paper.

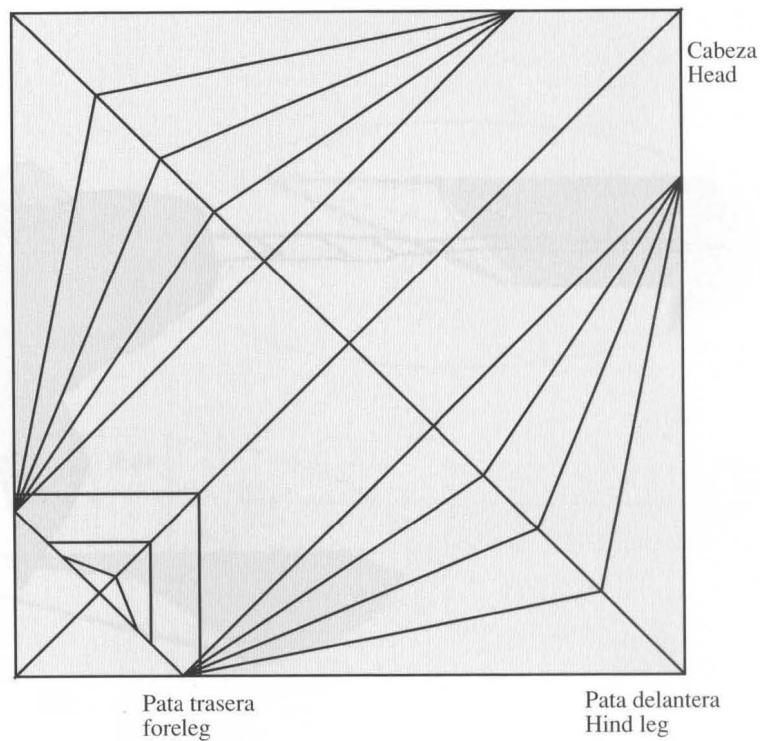
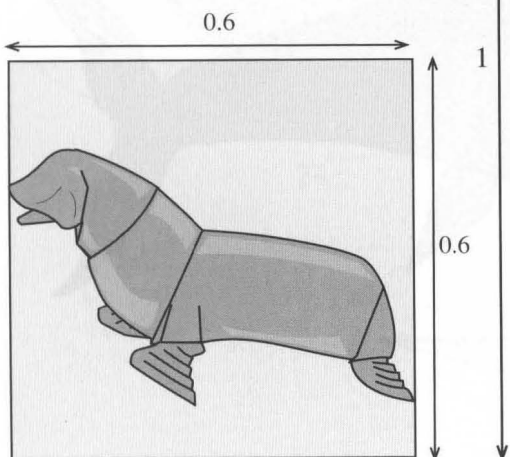

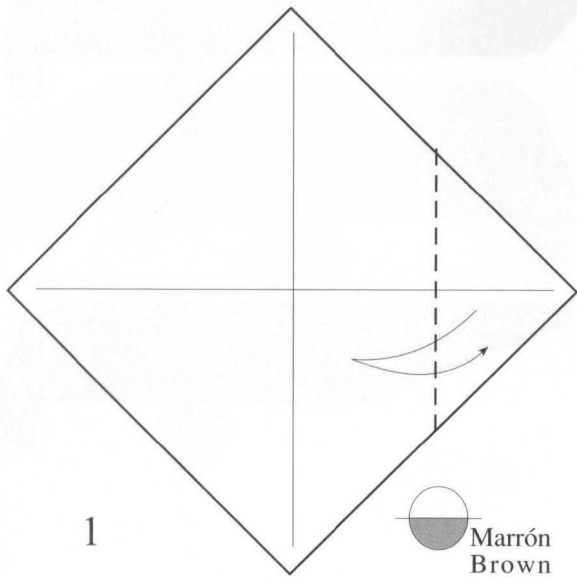

Pasos 2 al 13 del dugón
Steps 2 until 13 of dugón

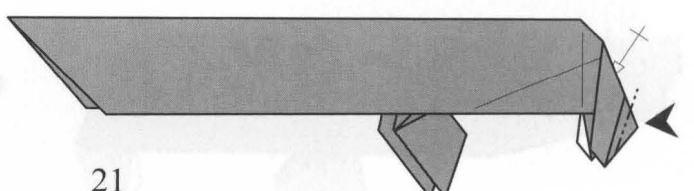
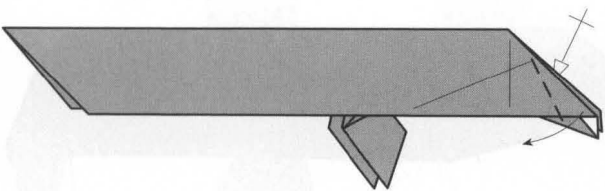
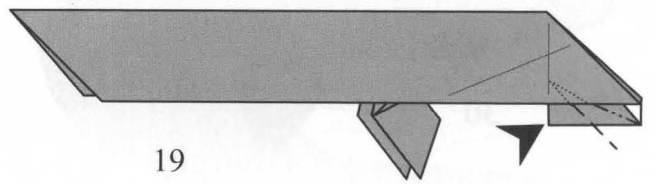
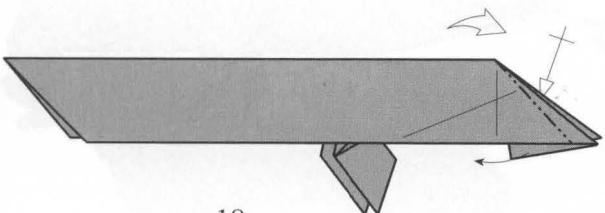
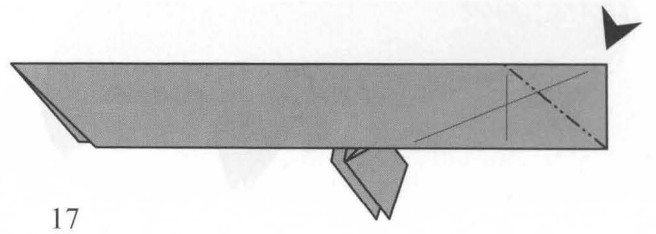
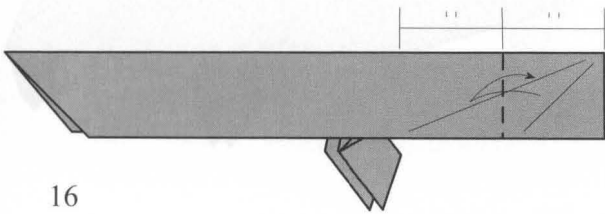
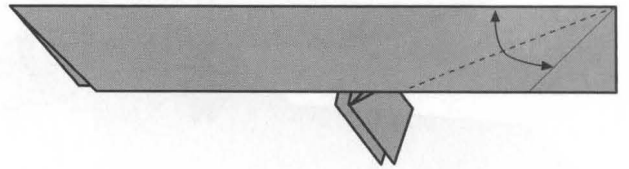
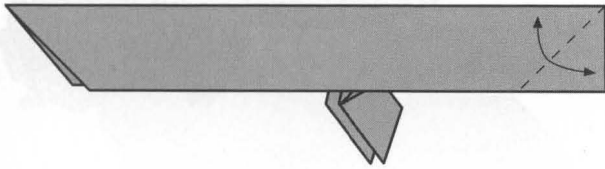

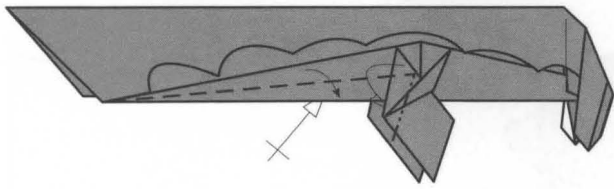

22

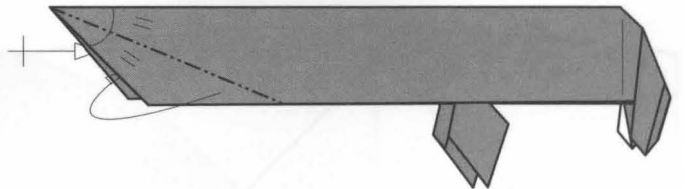

23

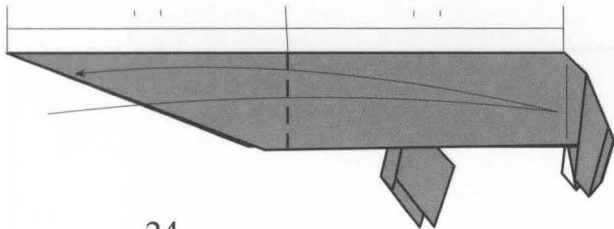

24

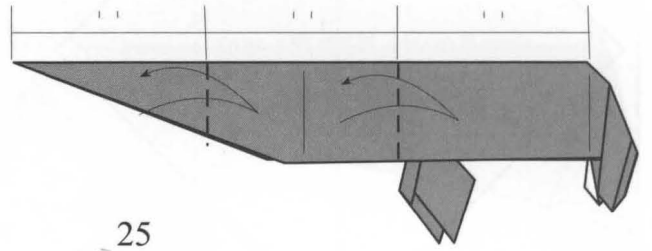

25

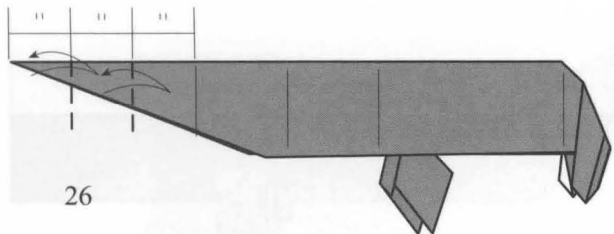

26

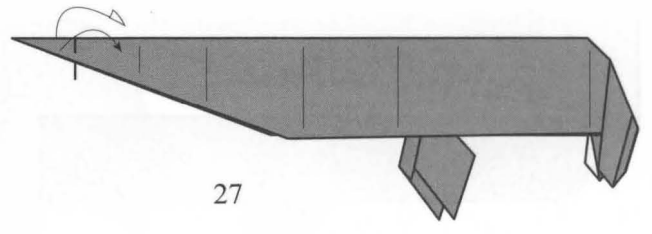

27

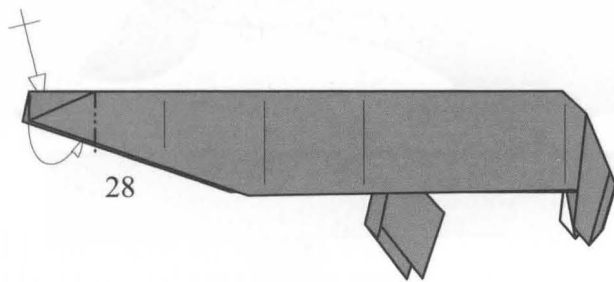

28

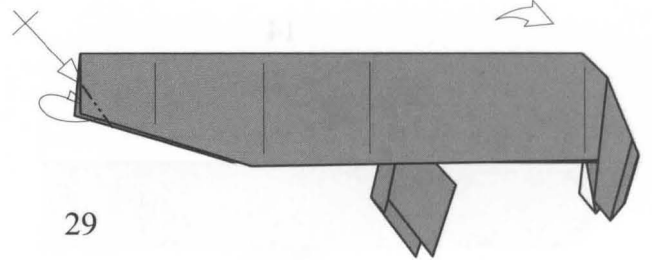

29

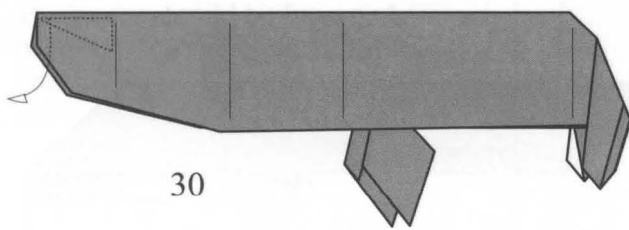

30

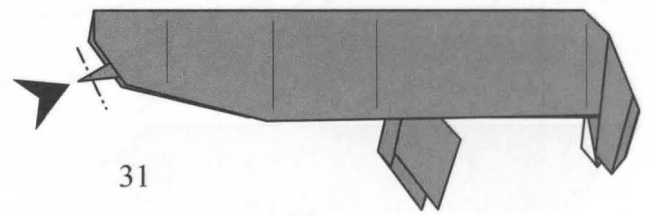

31

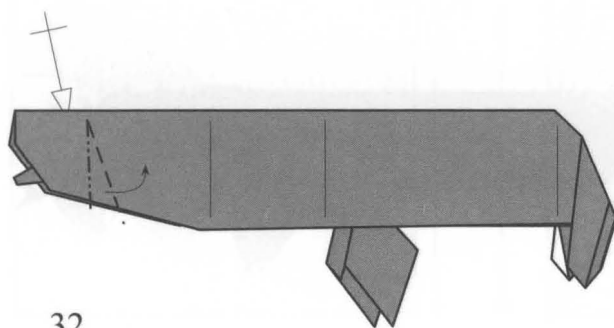

32

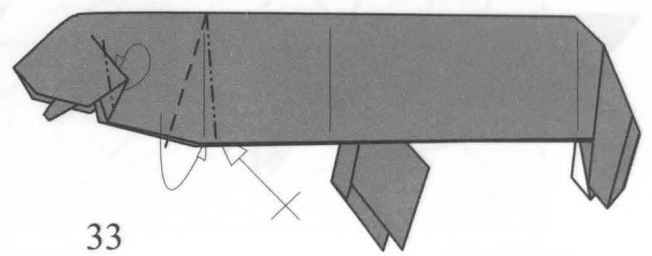

33

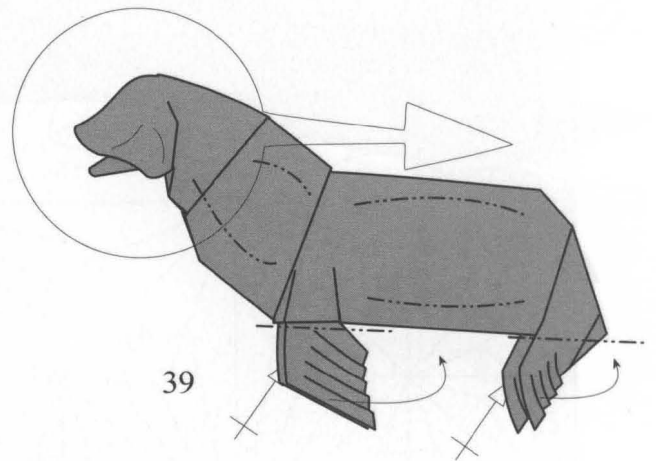
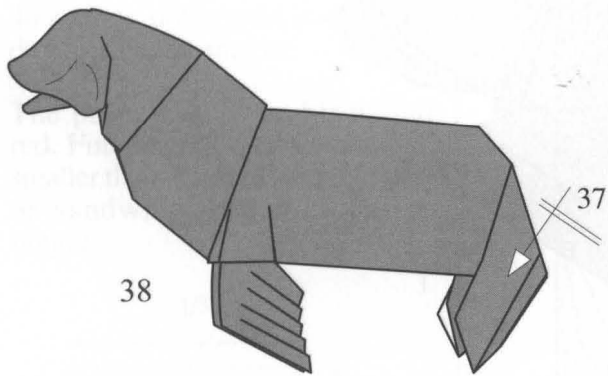
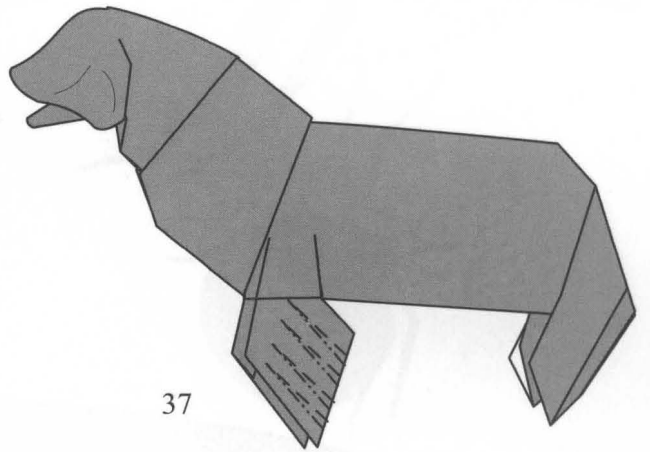
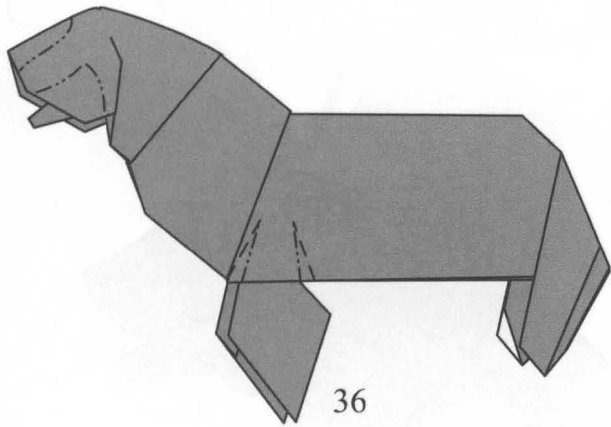
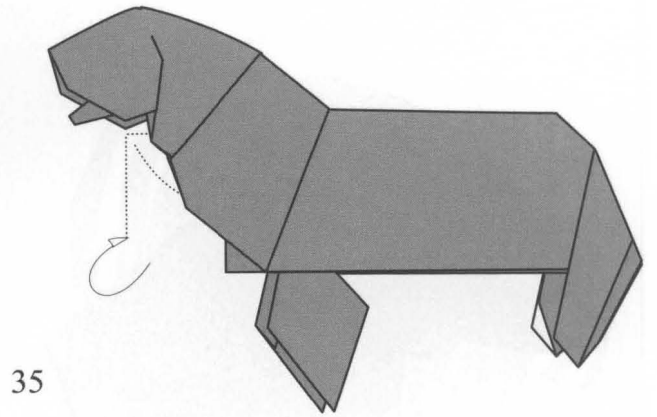
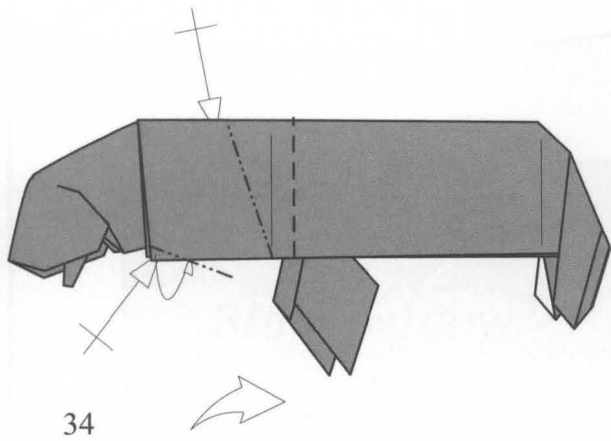

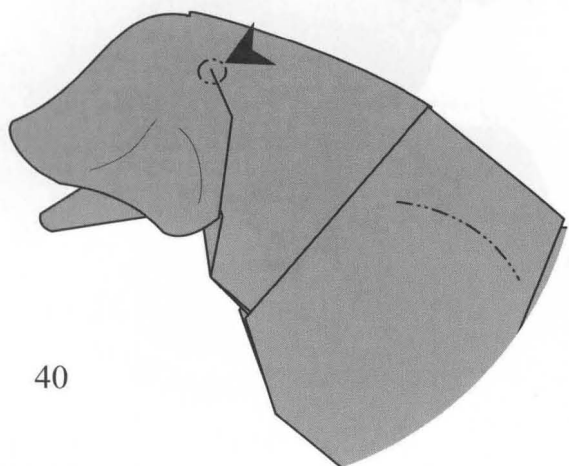

40

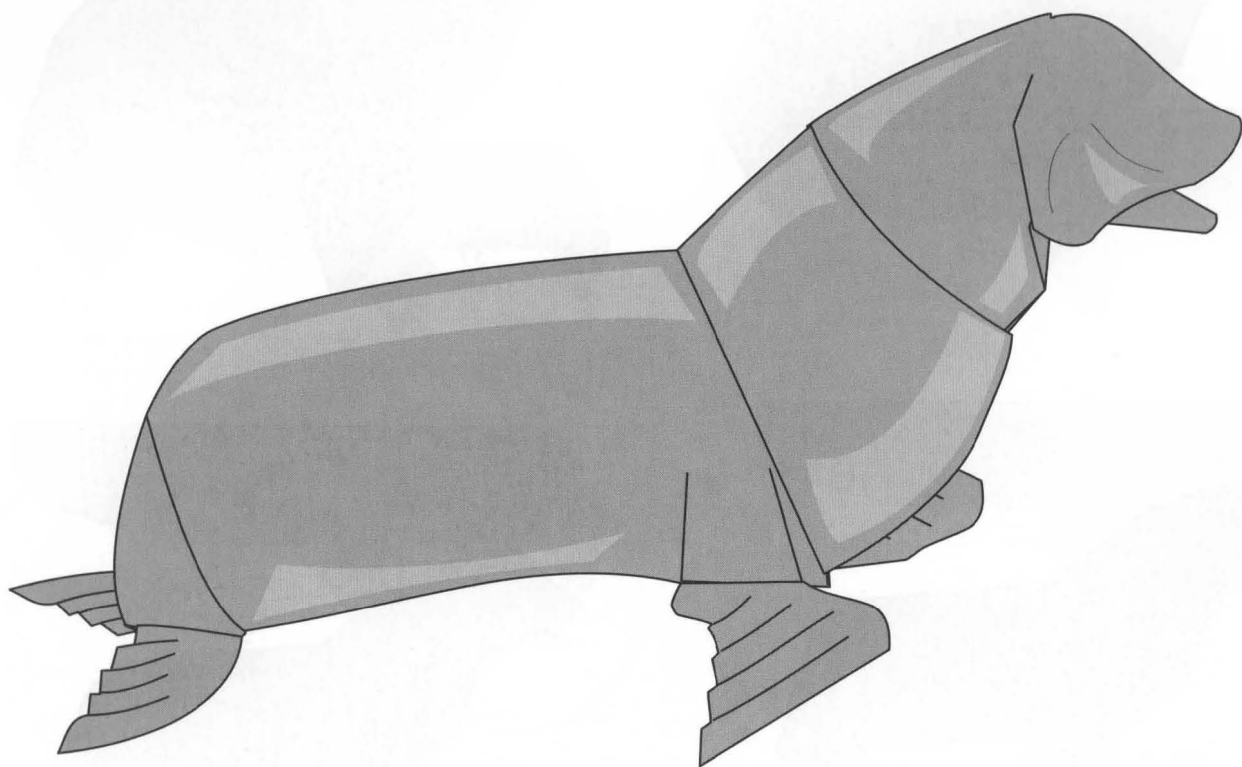

41

Viuda negra

Black widow

© M. Sirgo - 2001

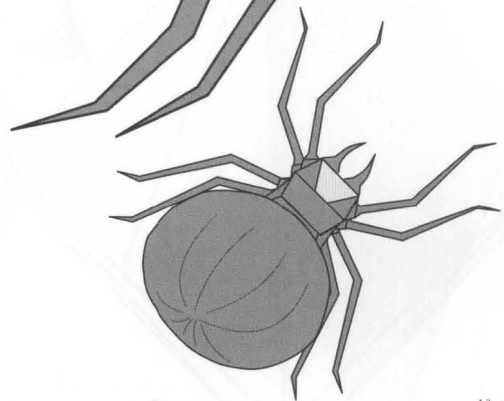
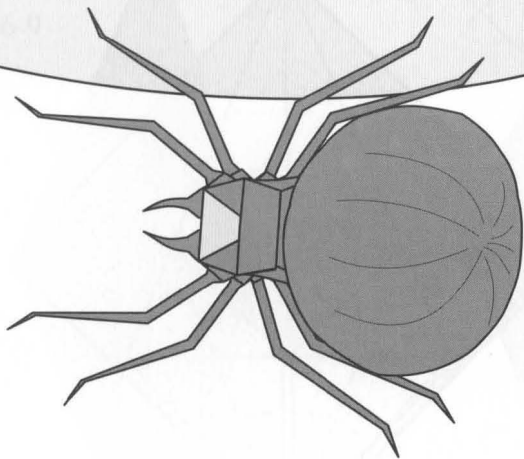
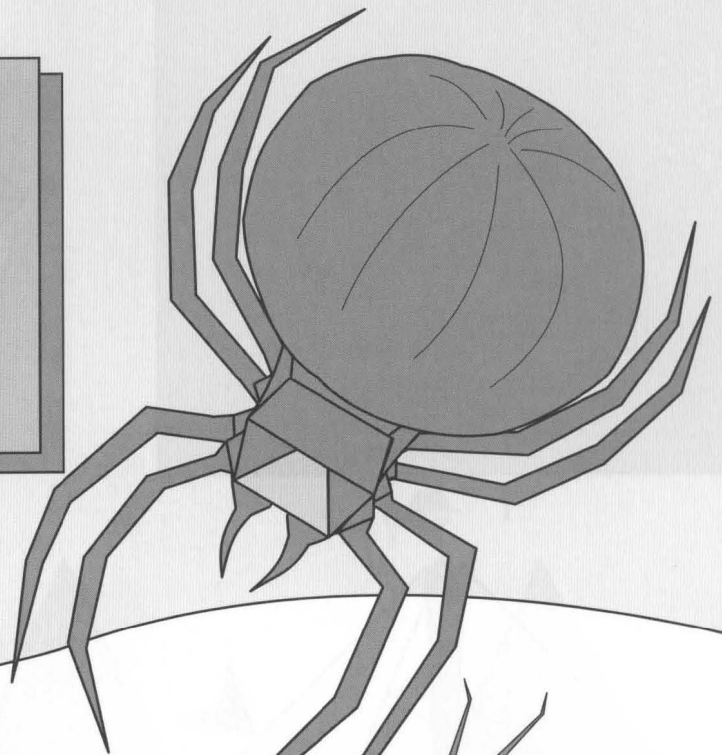

El papel debe ser negro y rojo. Se recomienda papel fino, menor de 40 gramos, doble seda, o sandwich de 15x15 cm o mayor.

The paper should be black and red. Fine paper is recommended, smaller than 40 grams, double silk, or sandwich of 15x15 cm or bigger..

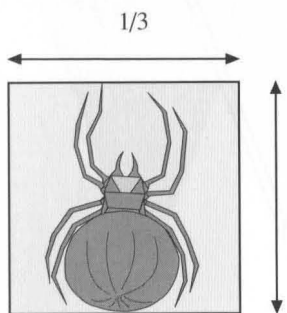
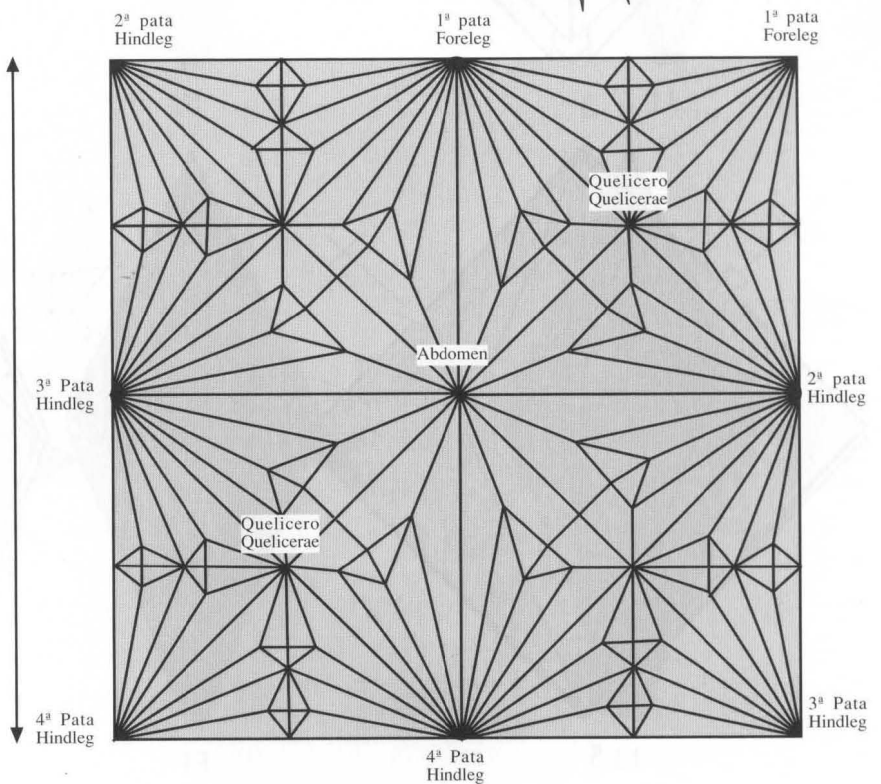

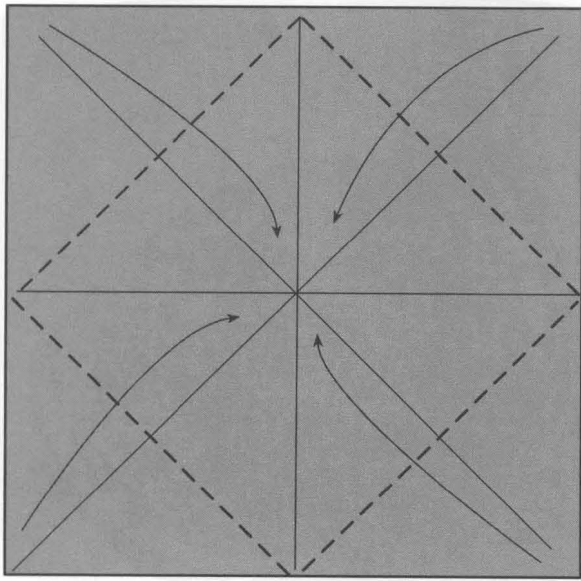

1

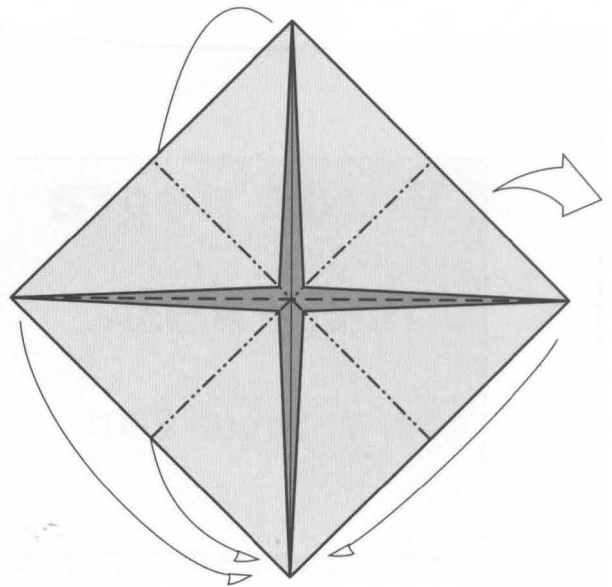

2

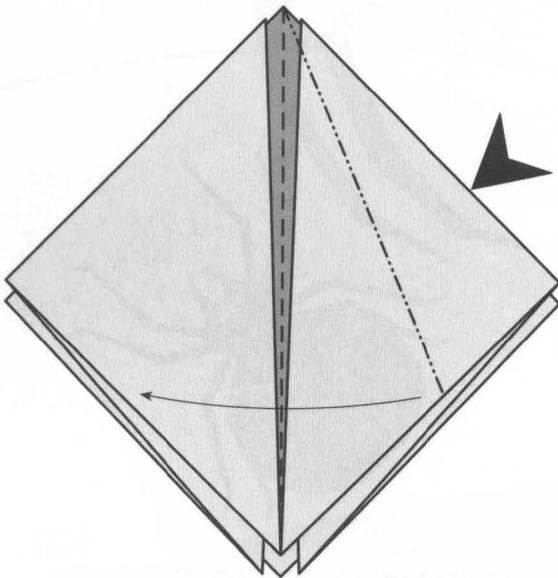

3

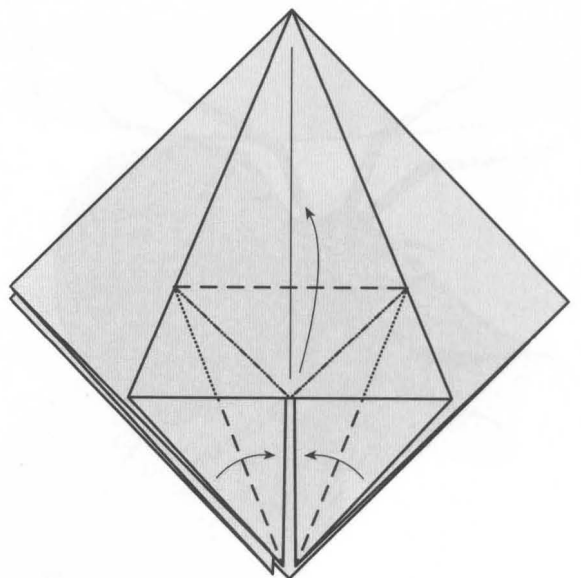

4

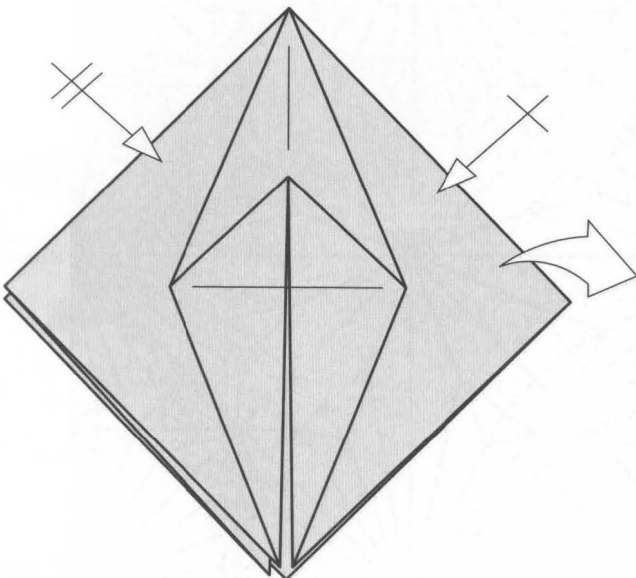

5

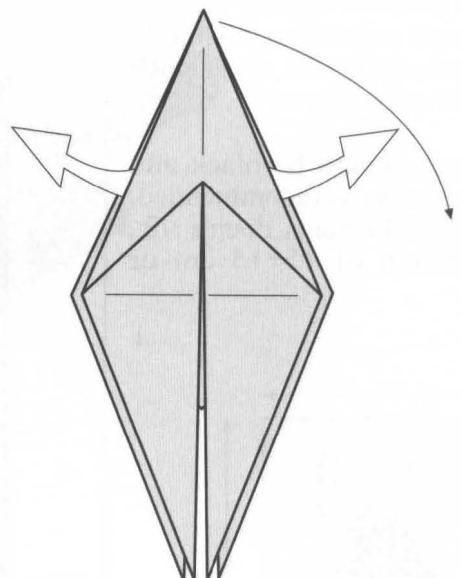

6

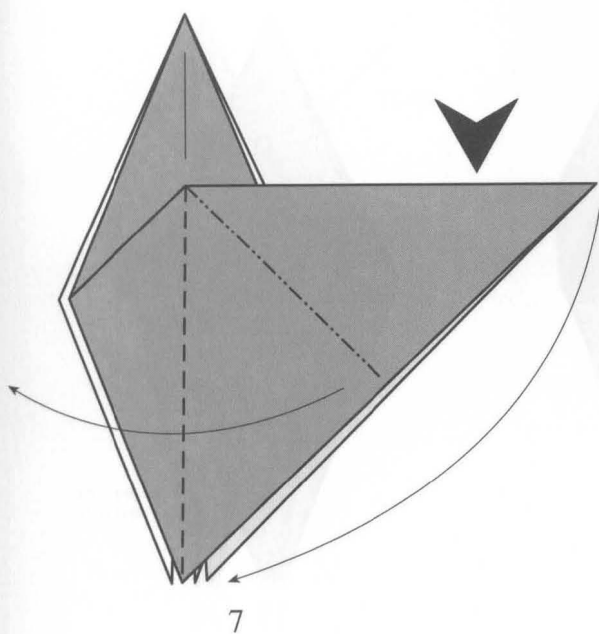

7

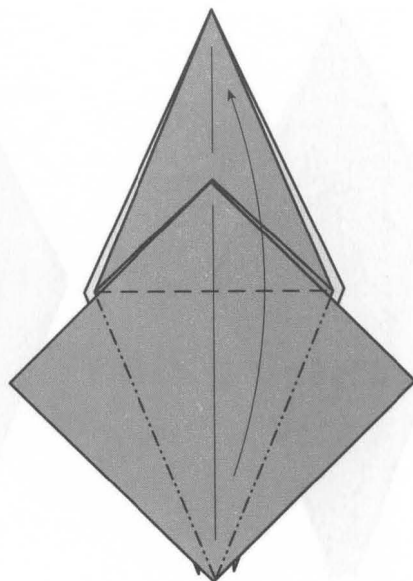

8

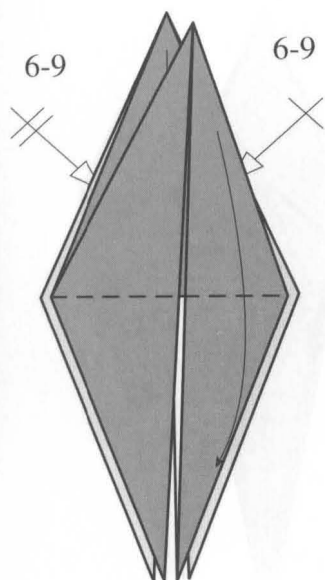

9

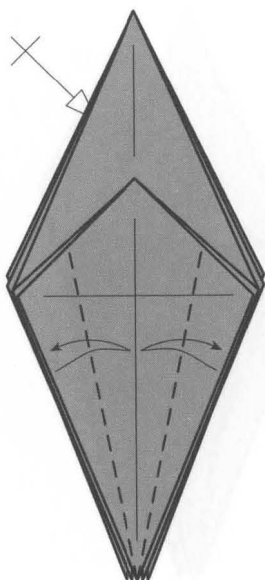

10

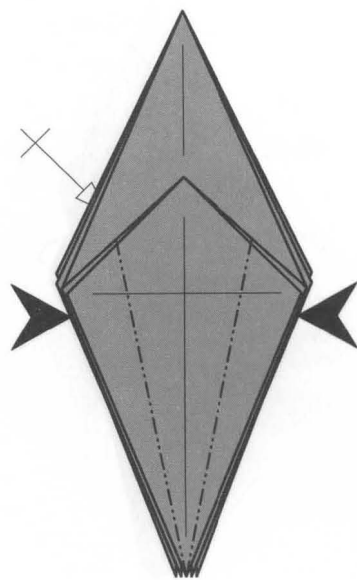

11

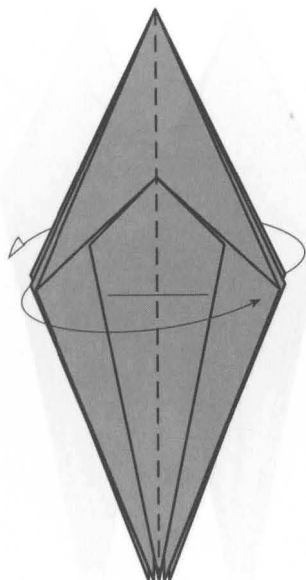

12

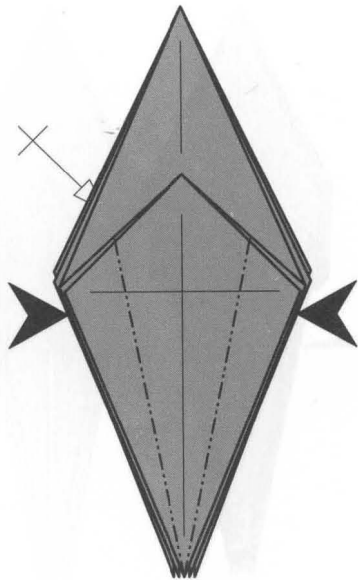

13

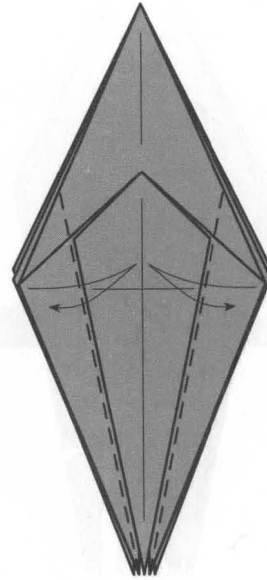

14

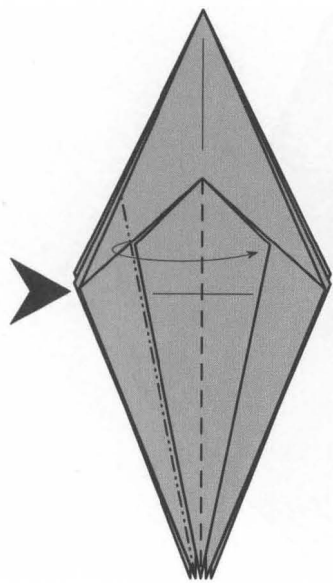

15

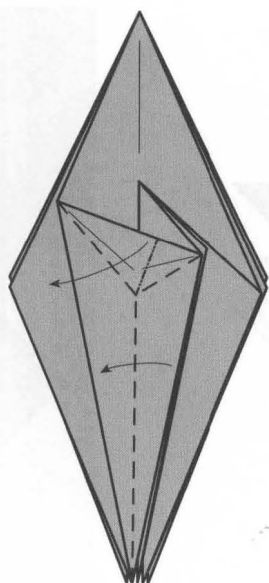

16

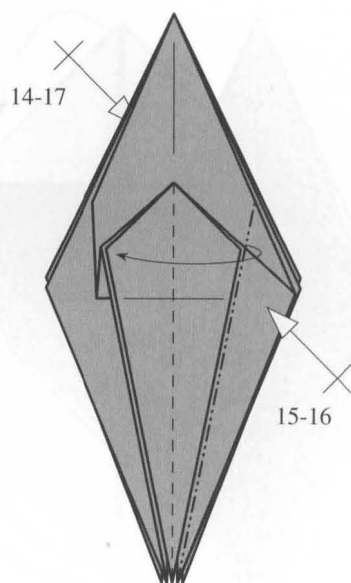

17

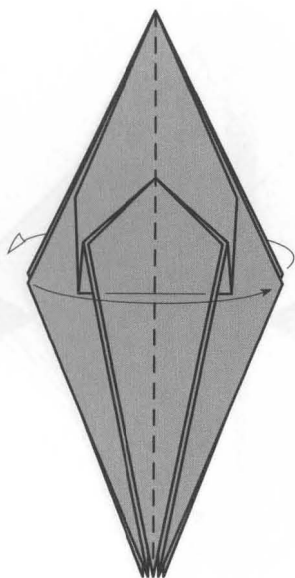

18

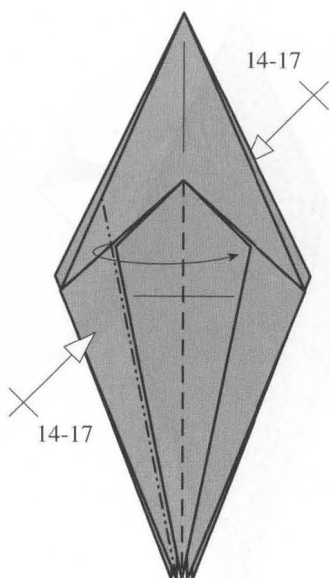

19

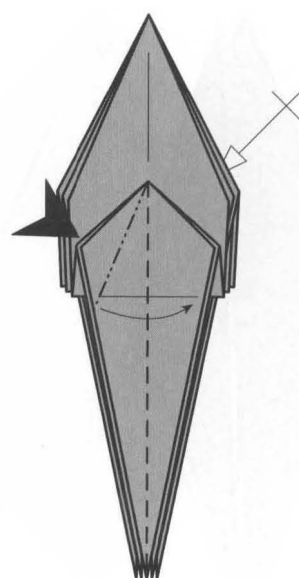

20

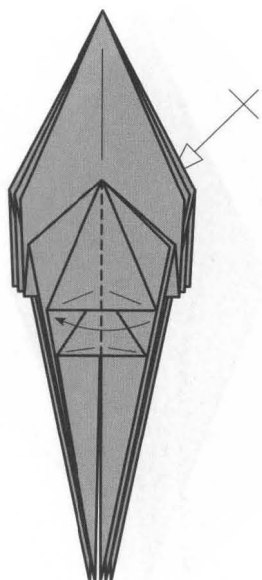

21

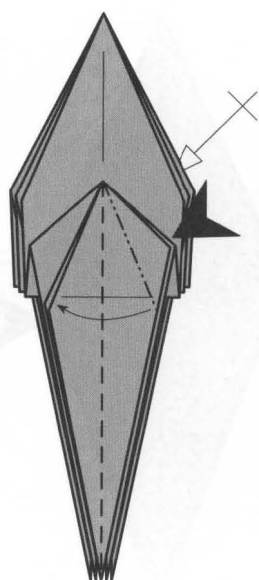

22

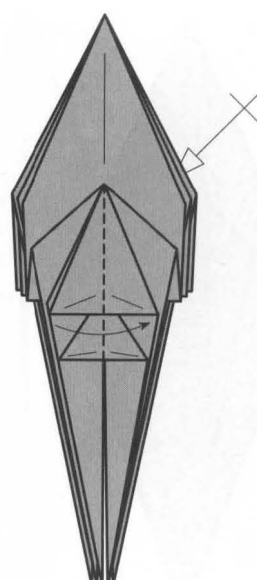

23

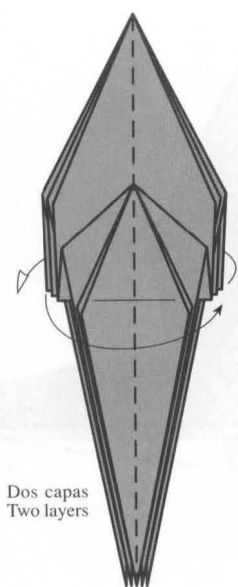

Dos capas
Two layers

24

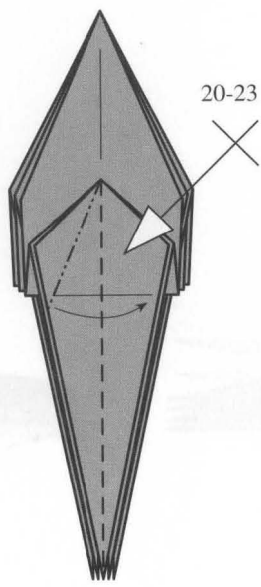

20-23

25

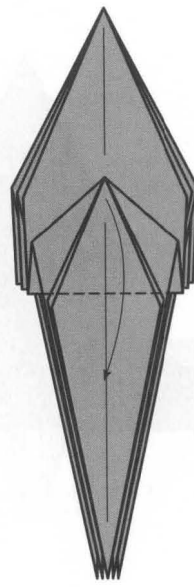

26

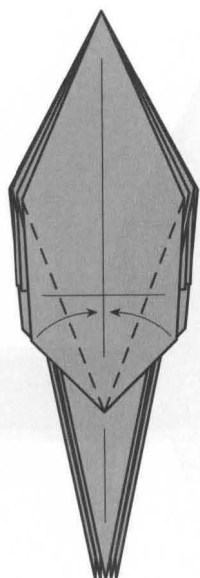

27

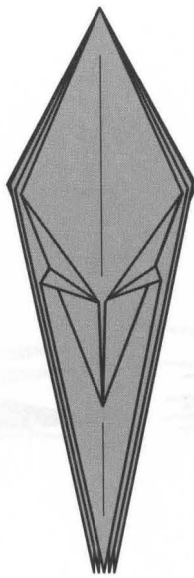

28

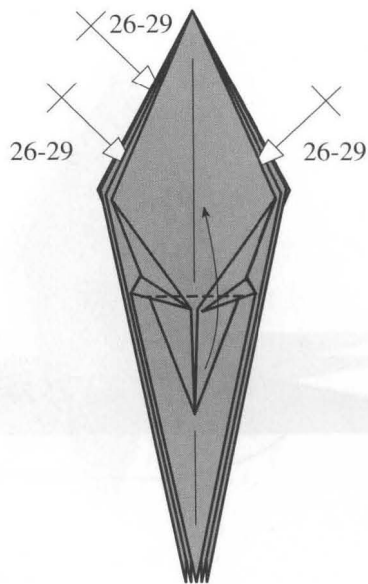

29

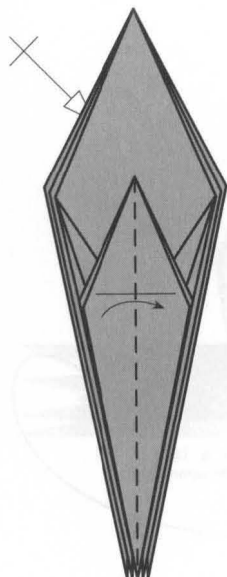

30

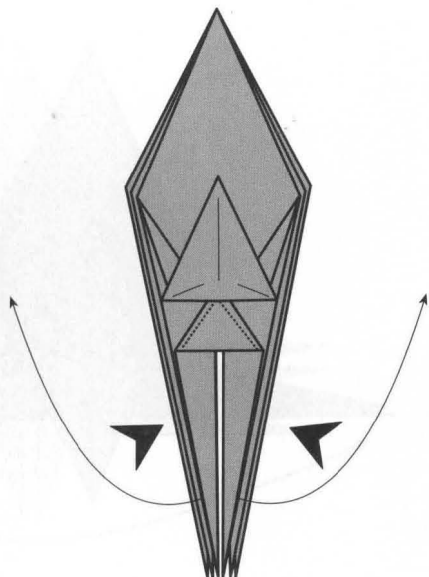

31

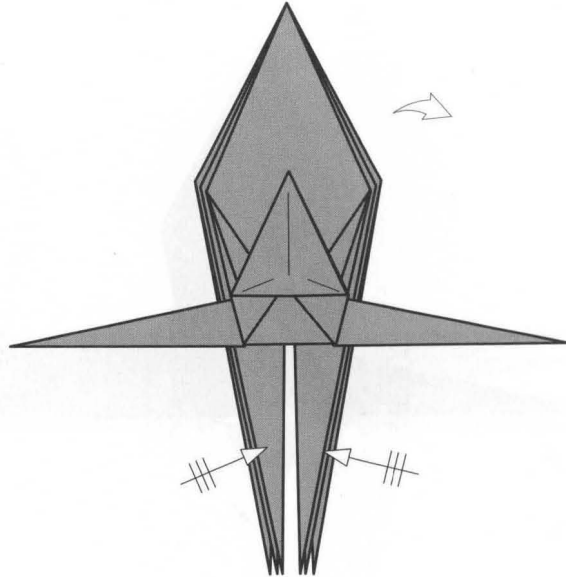

32

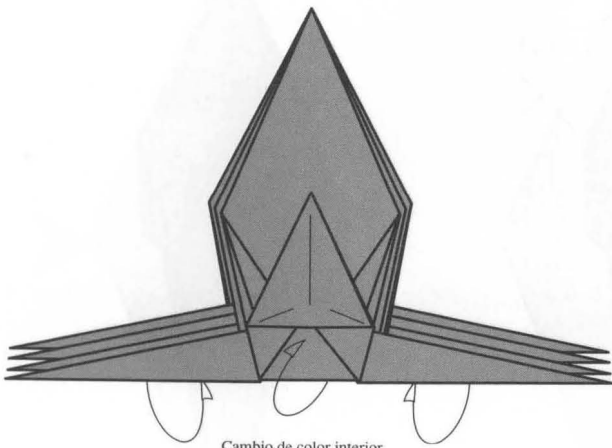

Cambio de color interior
Internal color change

33

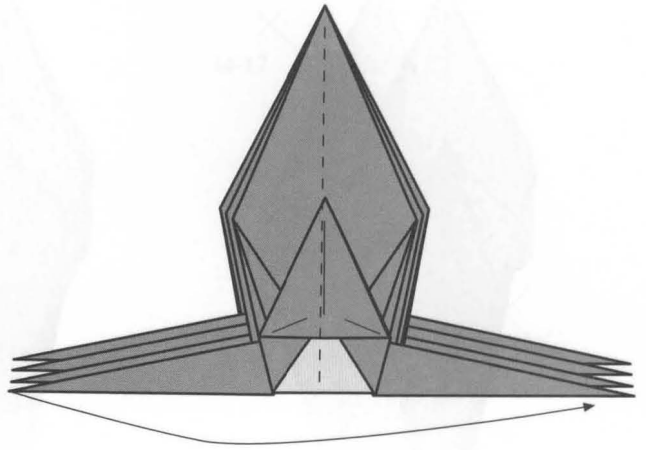

34

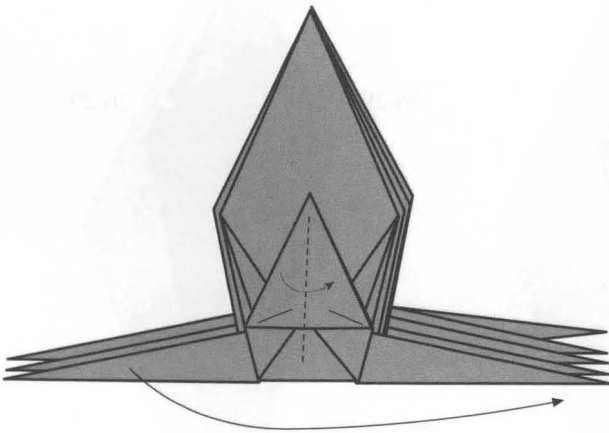

35

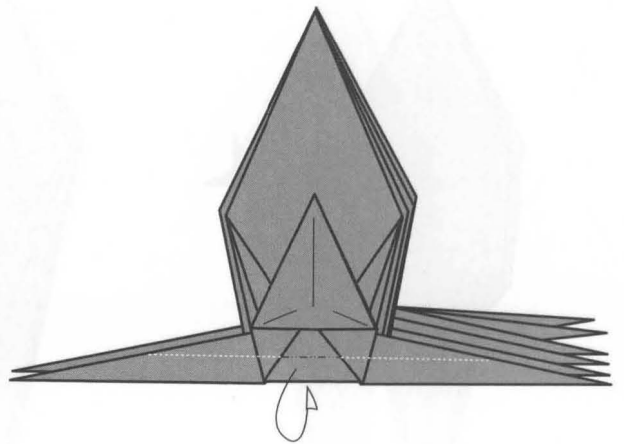

36

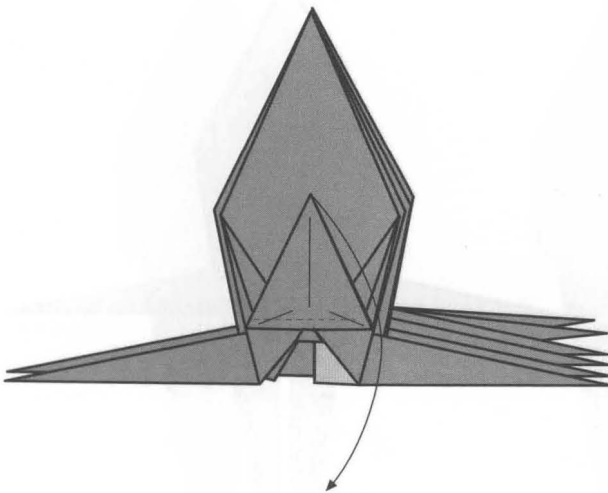

37

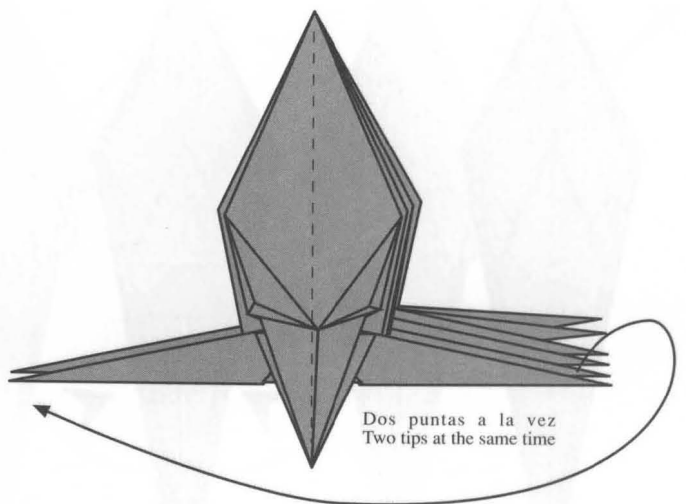

Dos puntas a la vez
Two tips at the same time

38

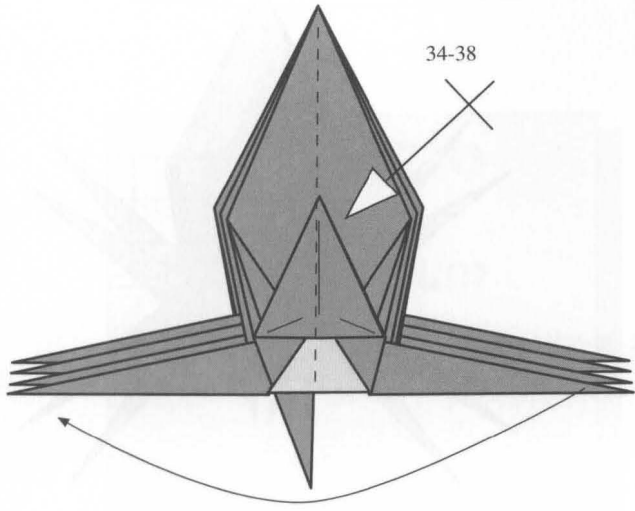

39

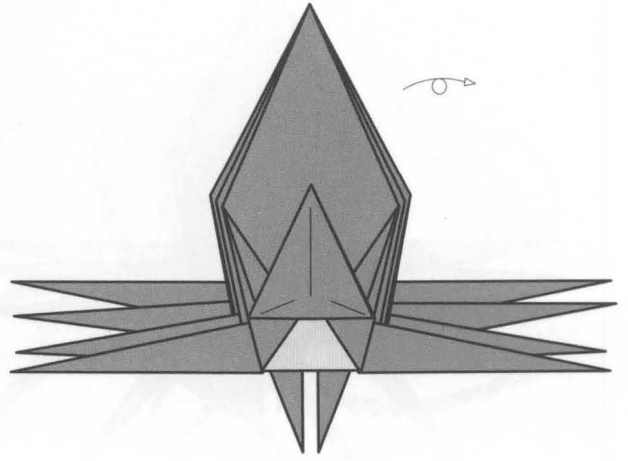

40

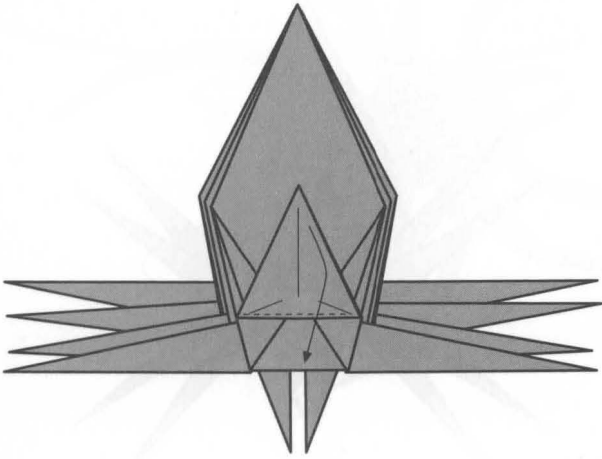

41

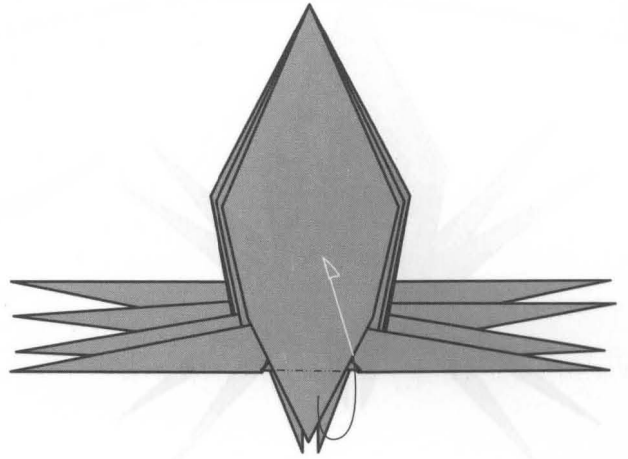

42

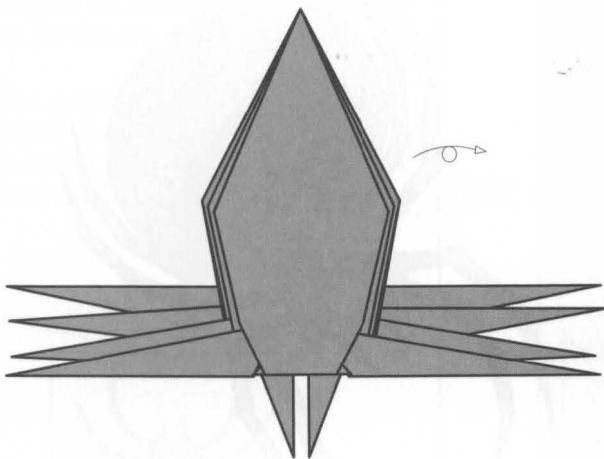

43

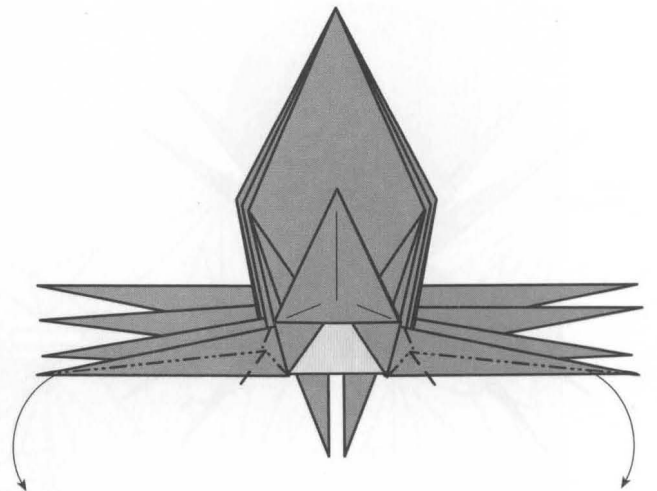

44

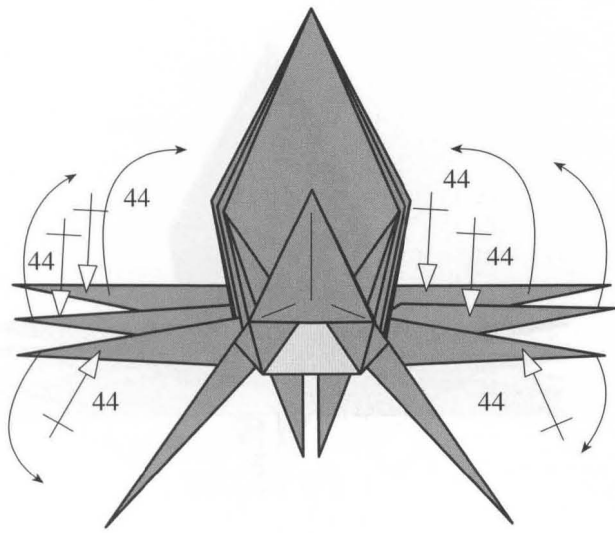

45

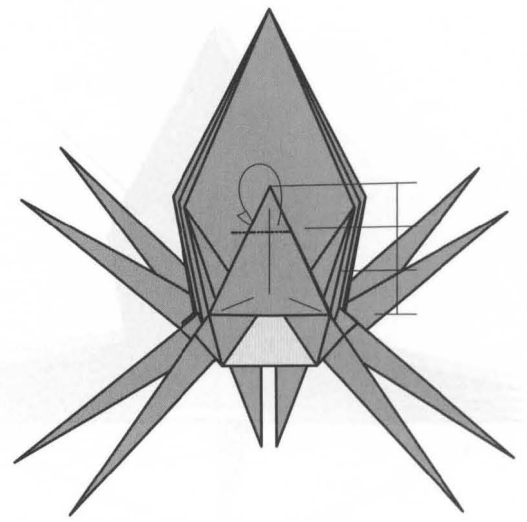

46

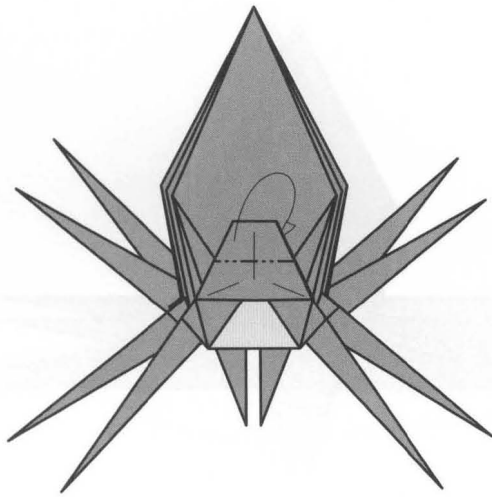

47

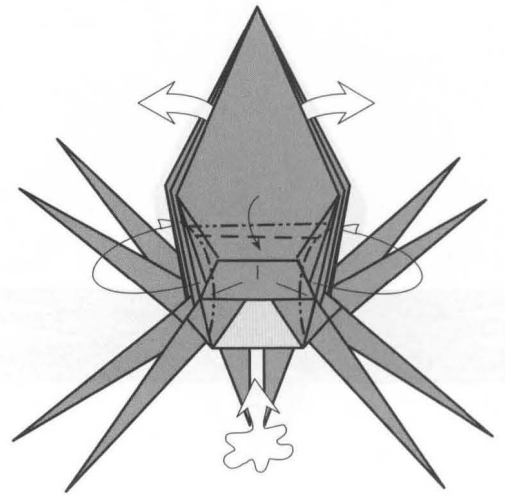

48

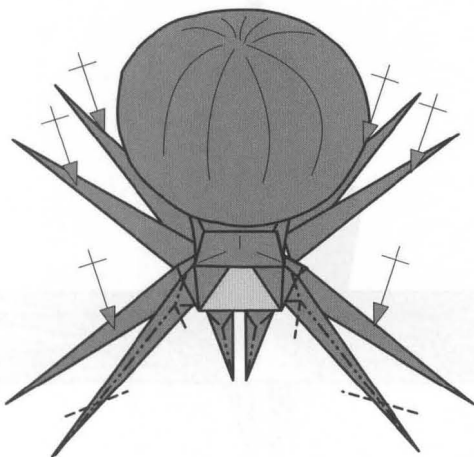

49

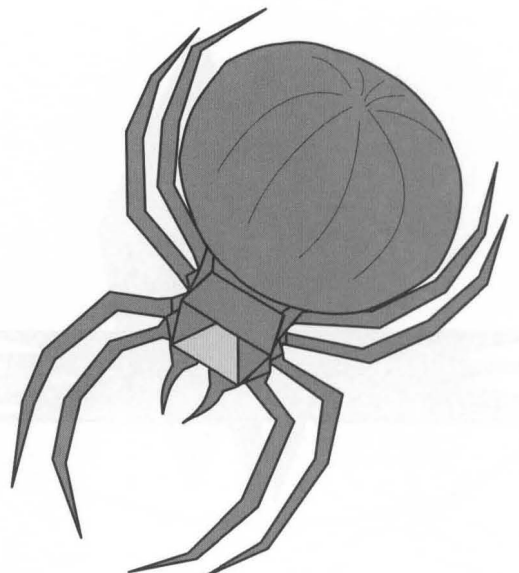

50

Falangio

Phalangium

© M. Sirgo - 2003

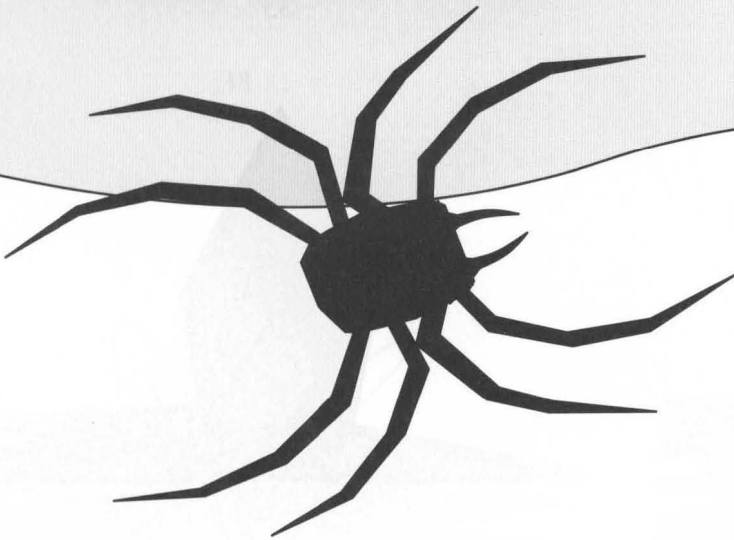
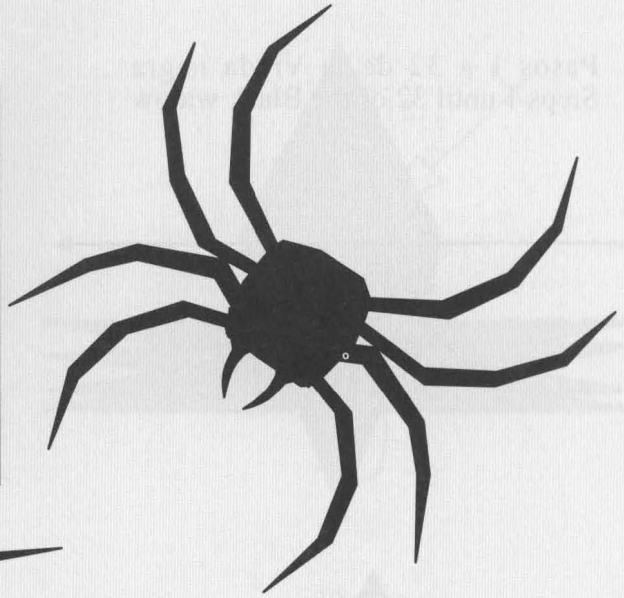

El papel debe ser negro. Se recomienda papel fino, menor de 30 gramos, doble seda, o *sandwich* de 20x20 cm o mayor.

The paper should be black. Fine paper is recommended, smaller than 30 grams, double silk, or *sandwich* of 20x20 cm or bigger.

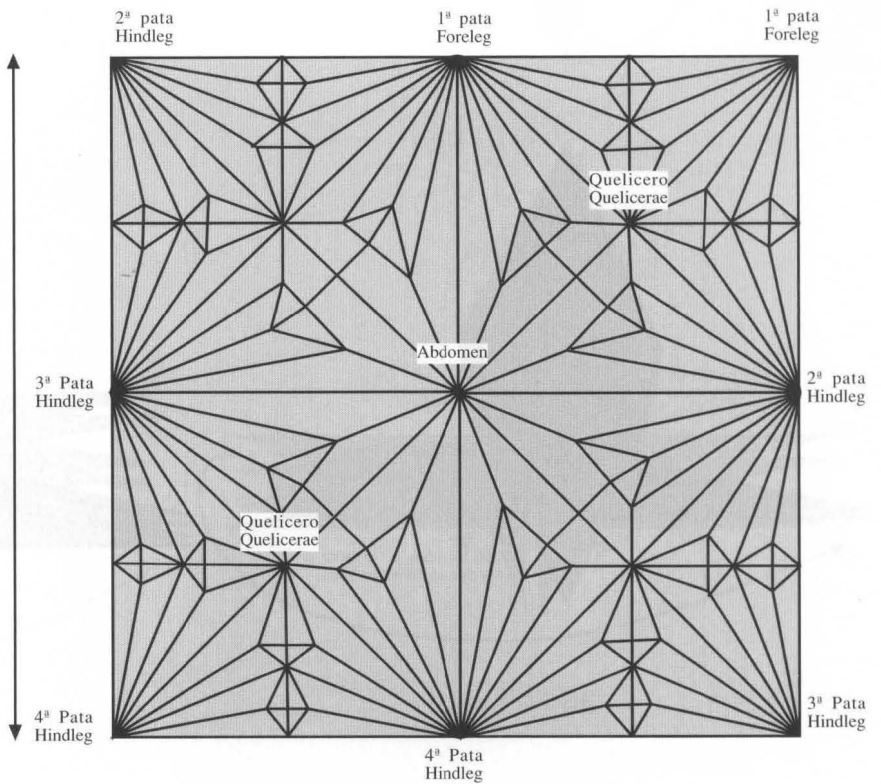
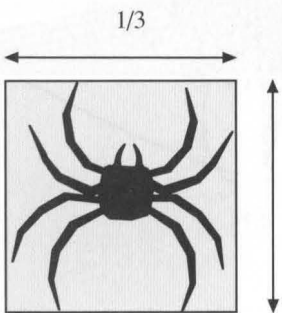

Pasos 1 a 32 de la Viuda negra
Steps 1 until 32 of the Black widow

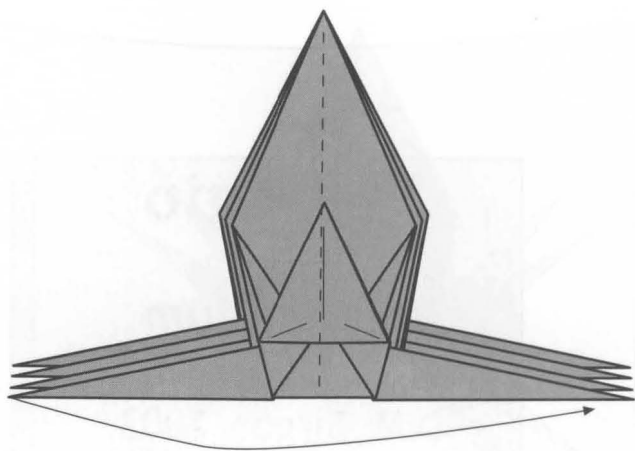

33

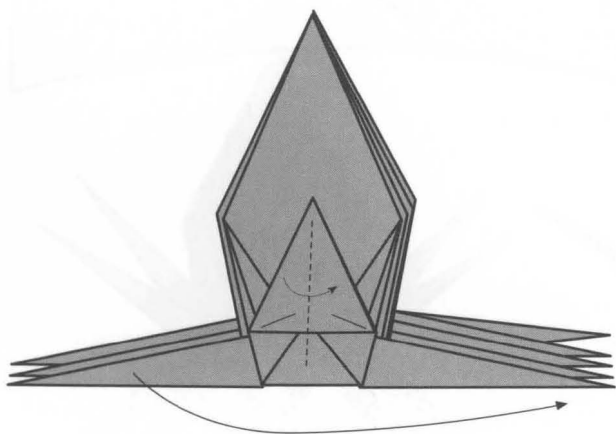

34

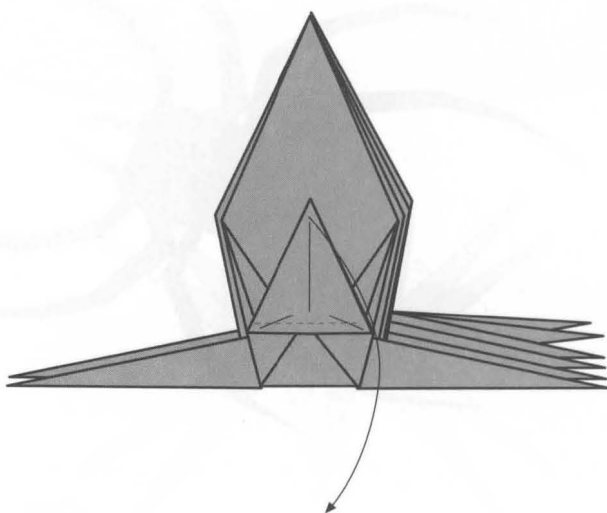

35

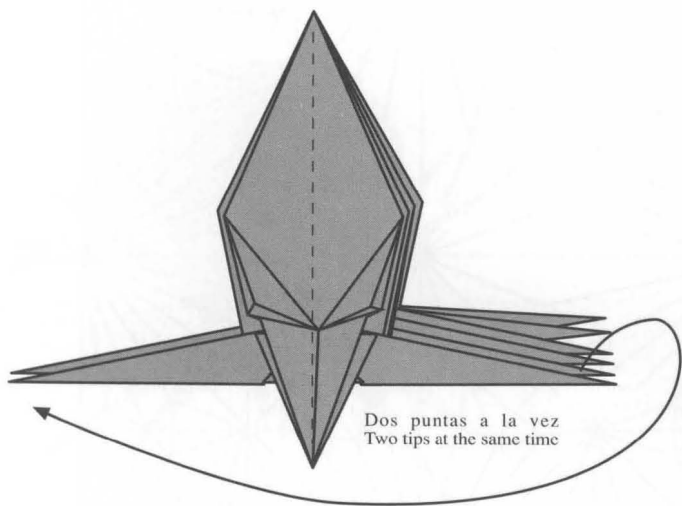

36

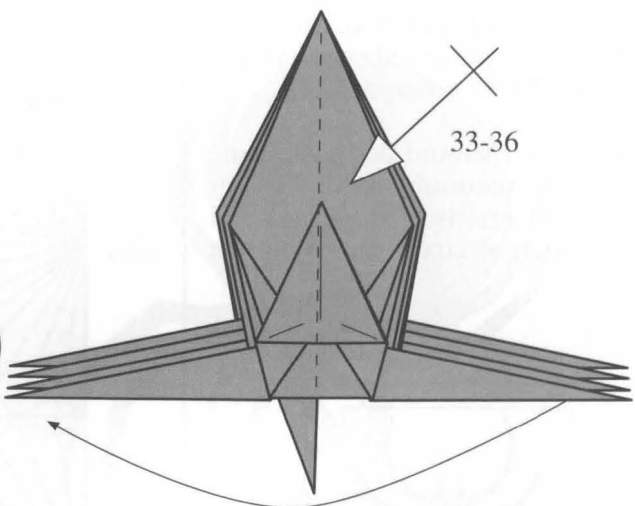

37

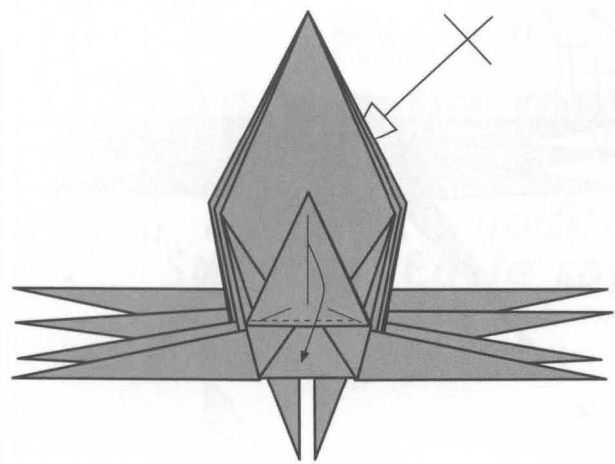

38

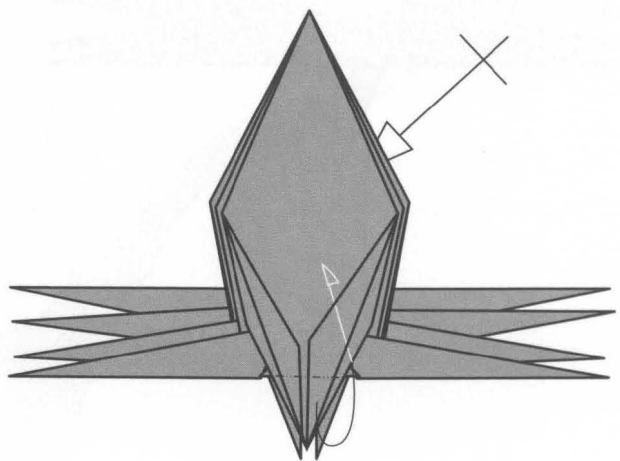

39

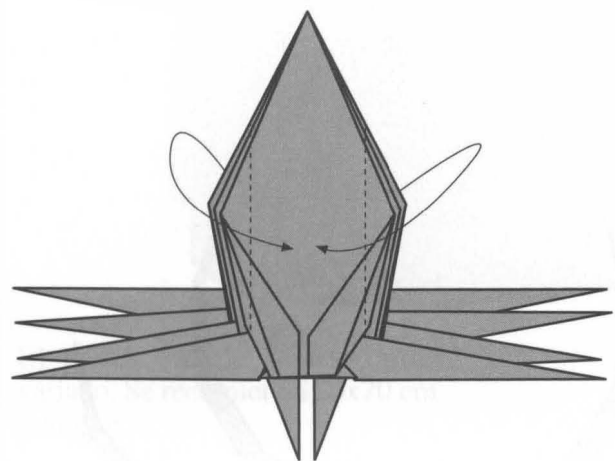

40

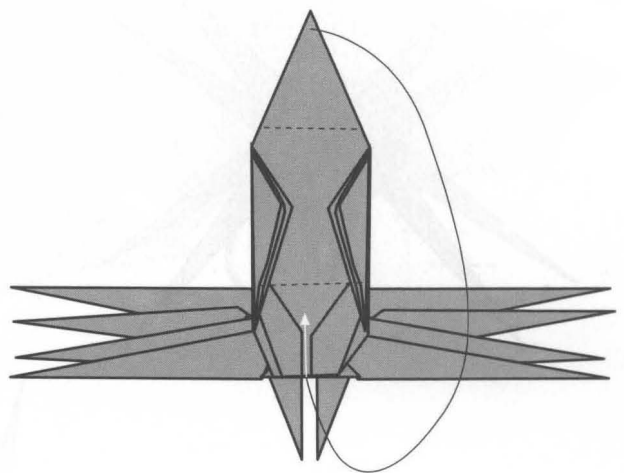

41

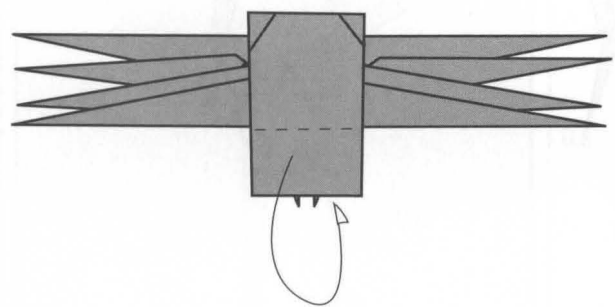

42

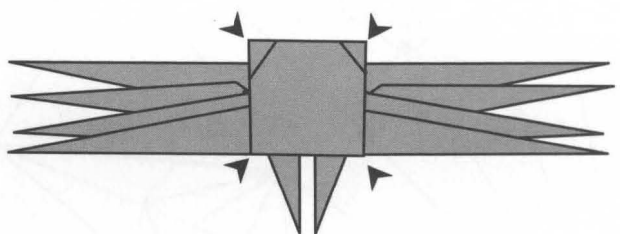

43

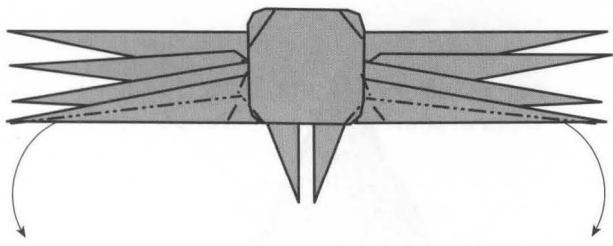

44

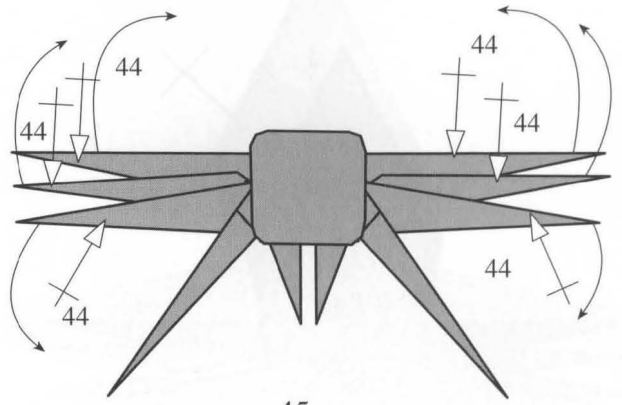

45

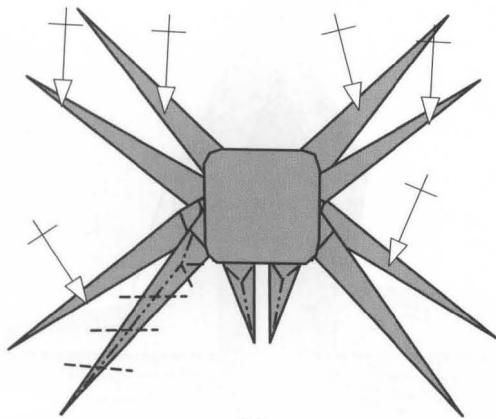

46

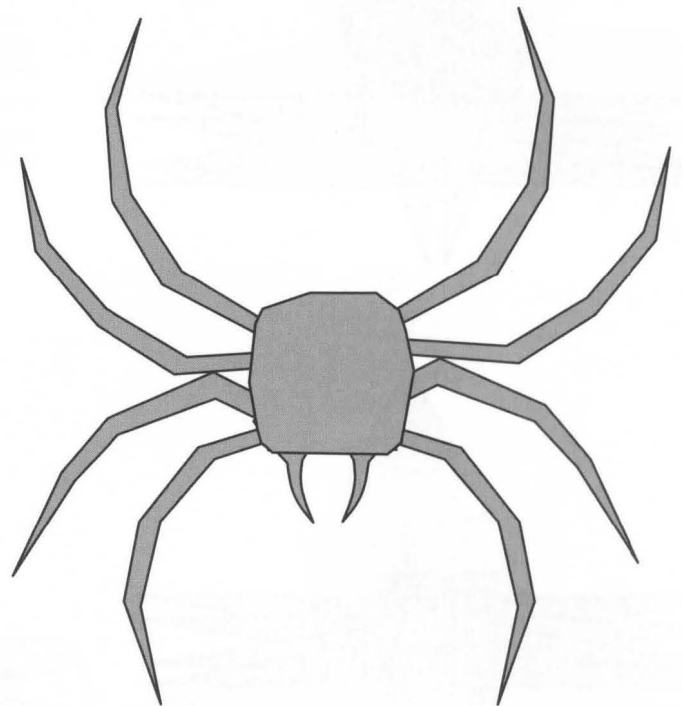

47

Raya Águila de mar

Myliobatis aquila
Stingray (Eagle ray)

© M. Sirgo - 2005

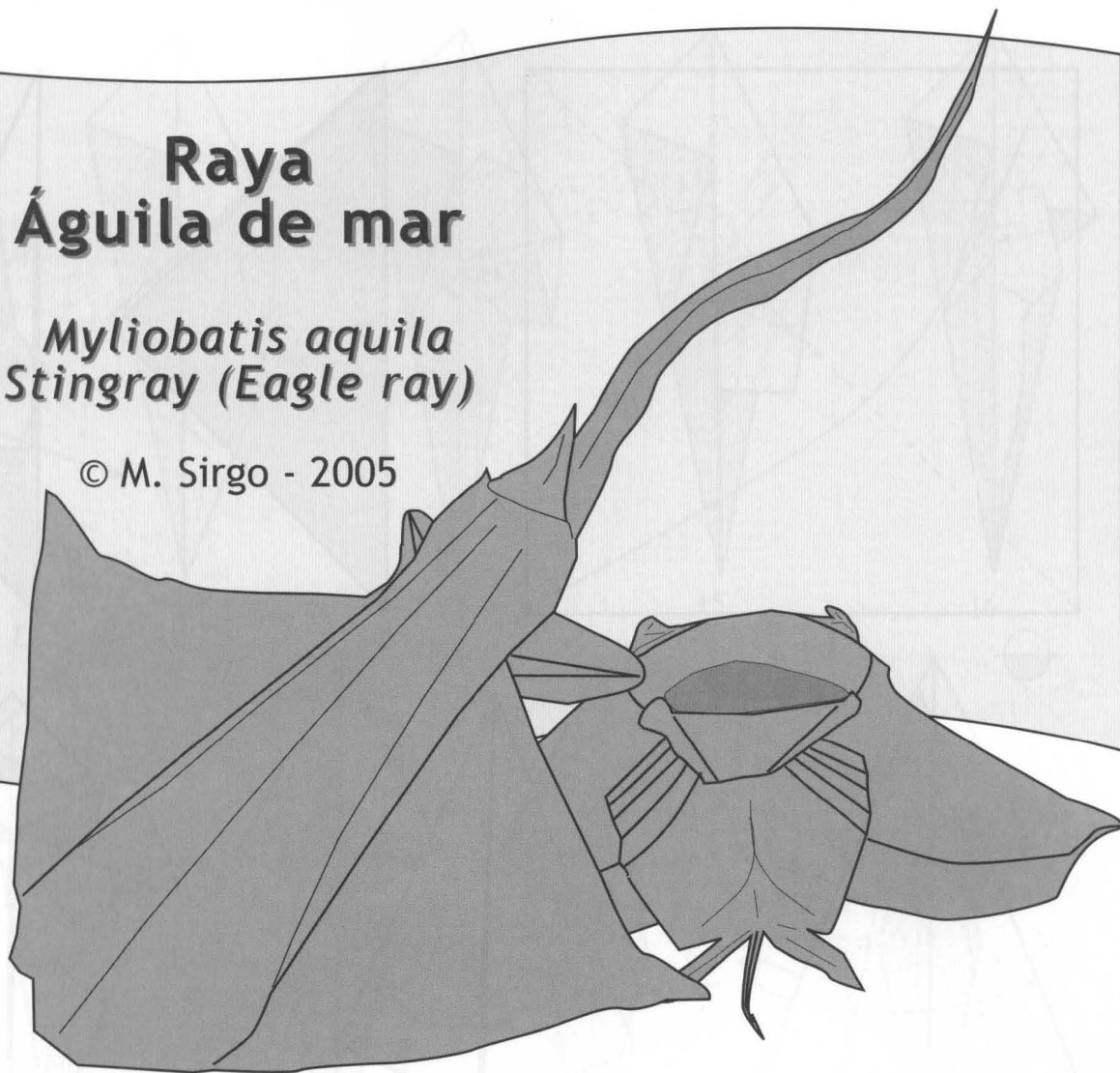

El papel puede ser de color
variado. Se recomienda 20x20 cm
o mayor.

The paper can be of varied
color. It is recommended 20x20
cm or bigger.

0.8

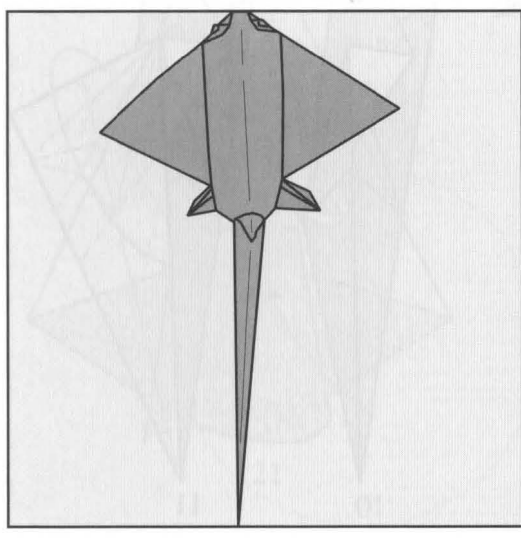

1

0.8

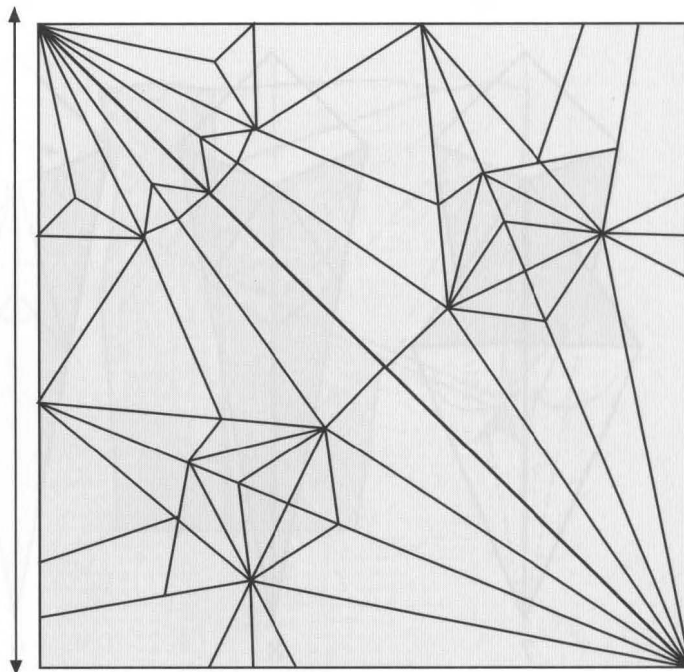

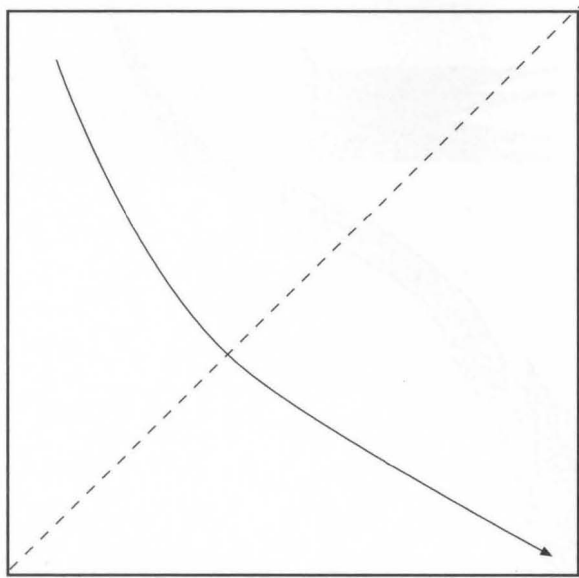

1

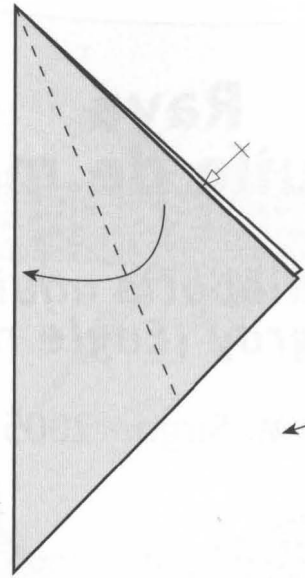

2

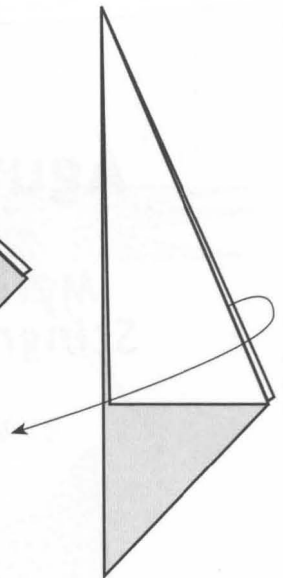

3

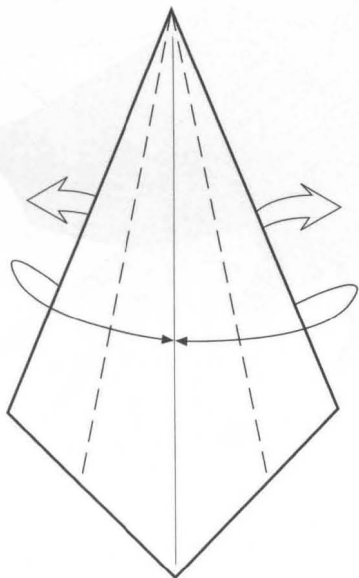

4

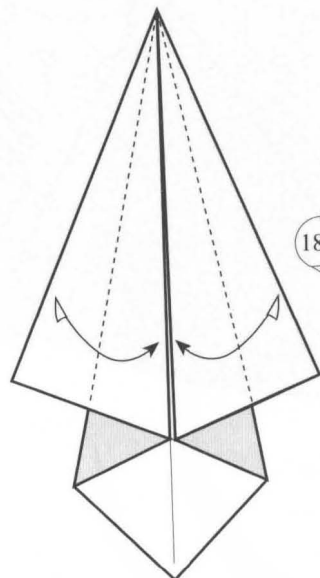

5

180°

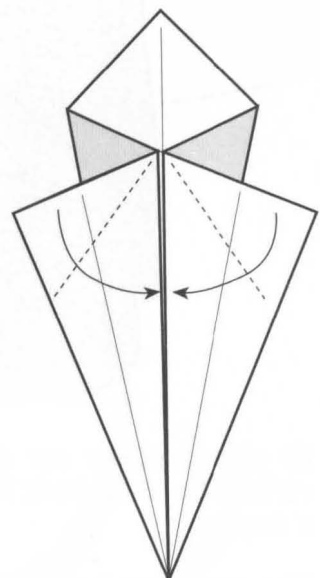

6

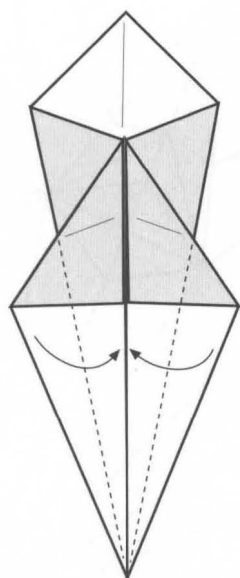

7

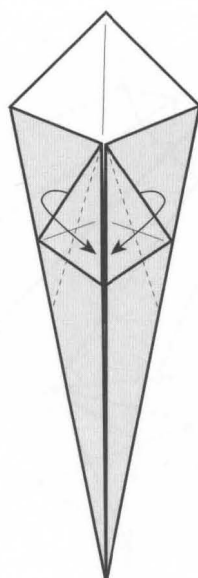

8

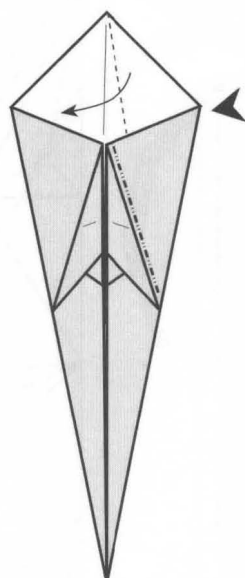

9

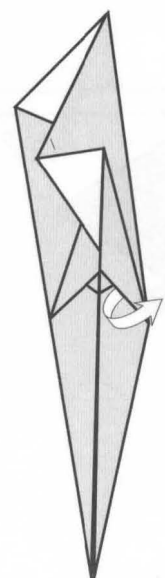

10

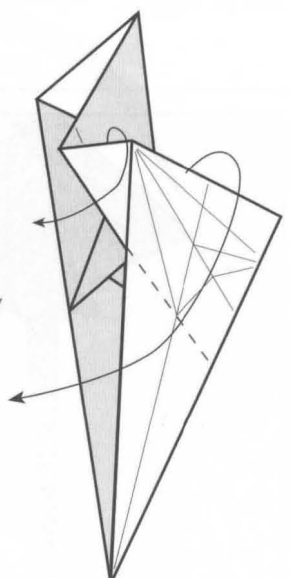

11

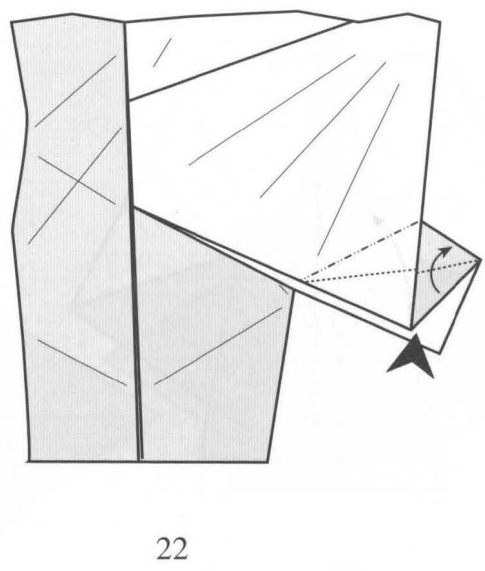
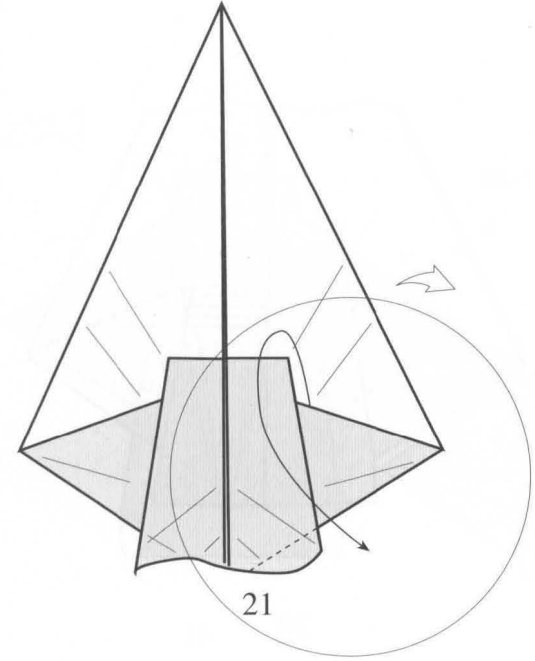
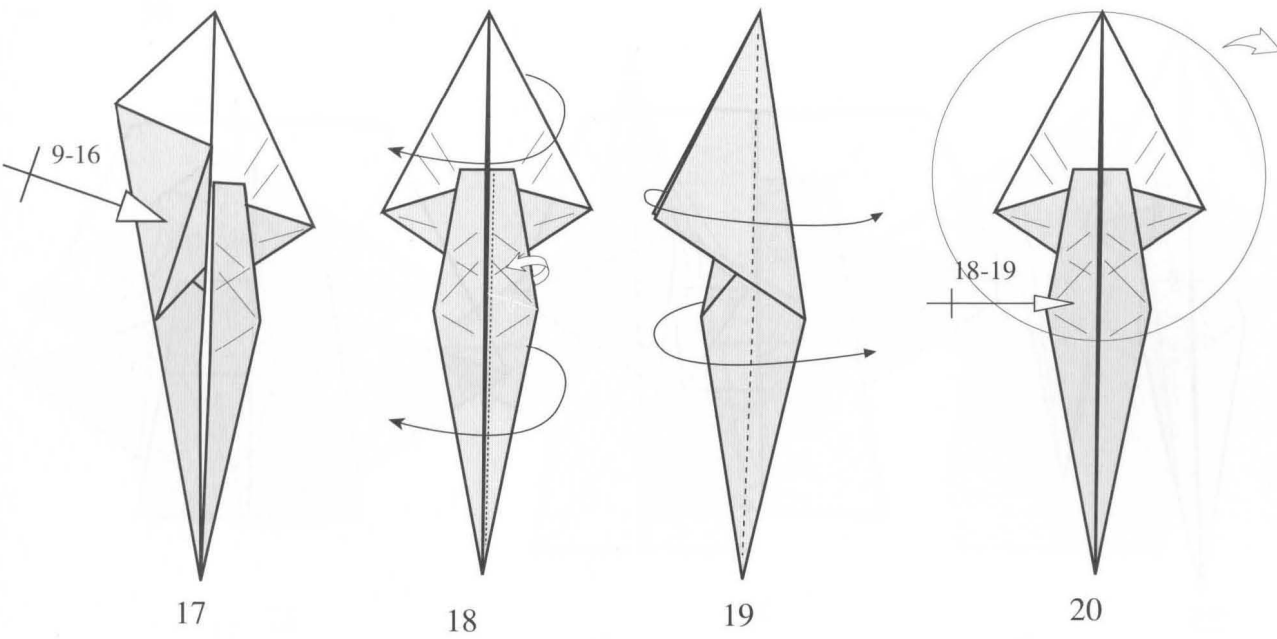
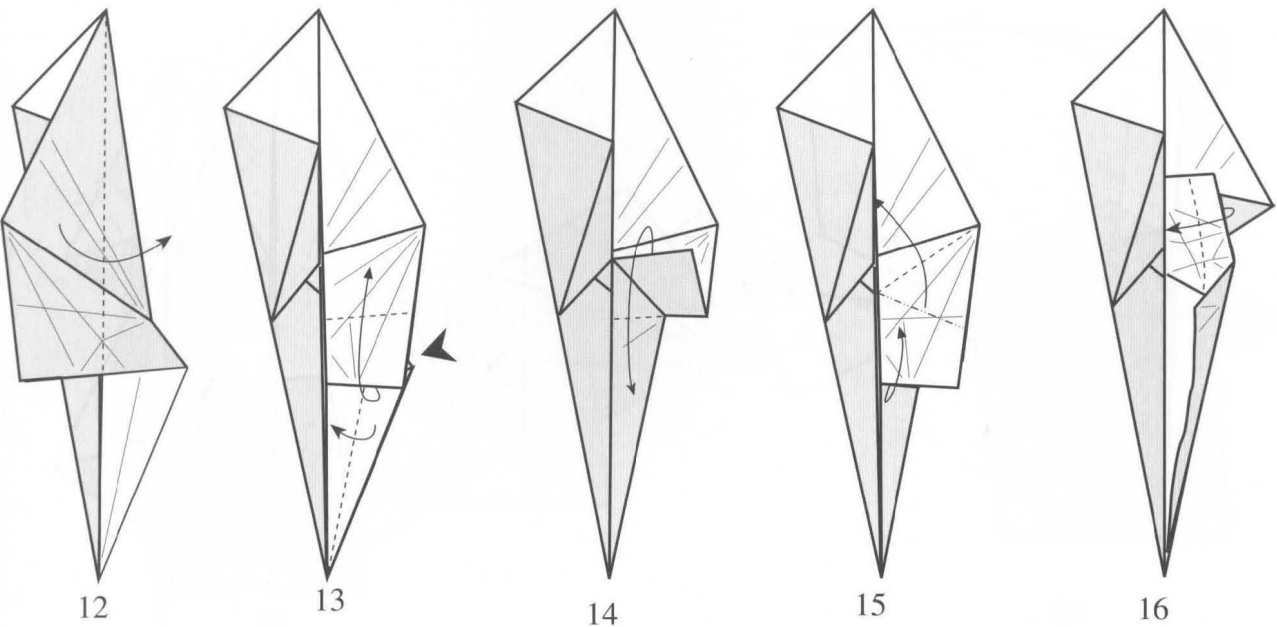

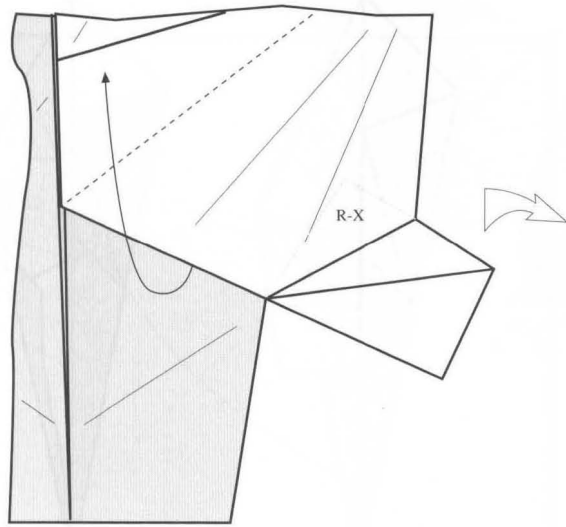

23

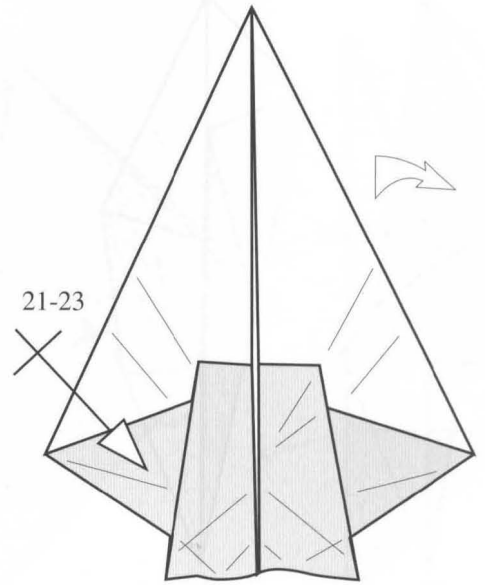

24

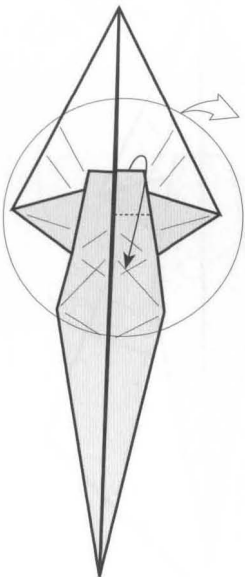

25

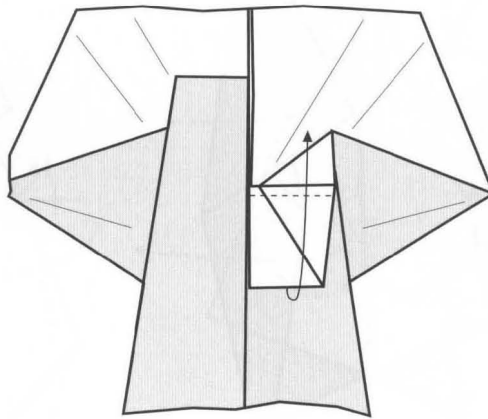

26

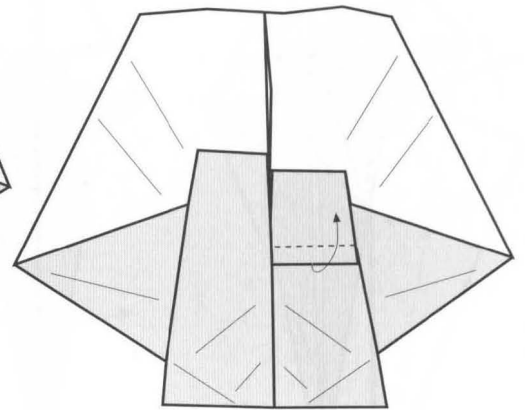

27

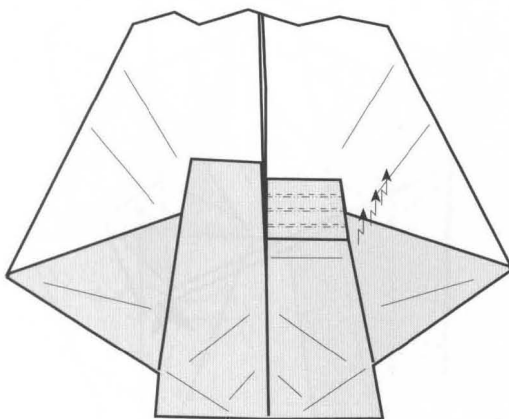

28

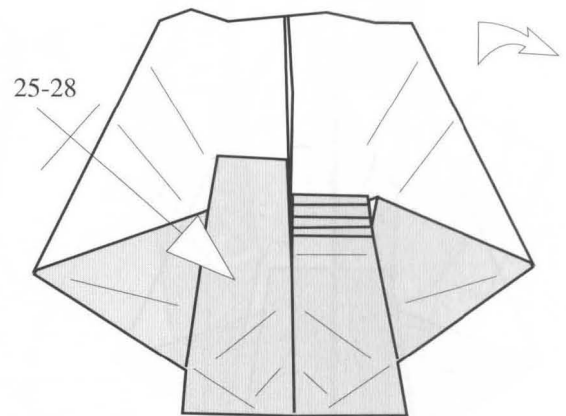

29

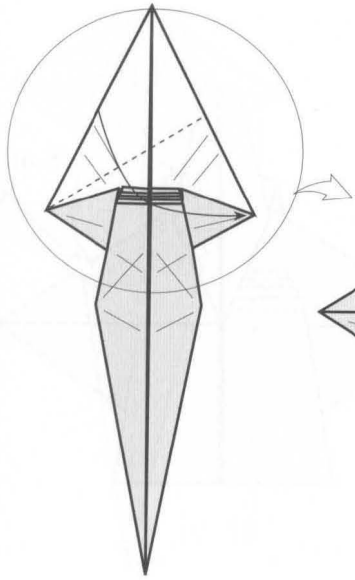

30

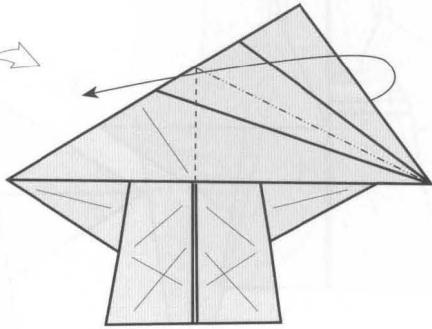

31

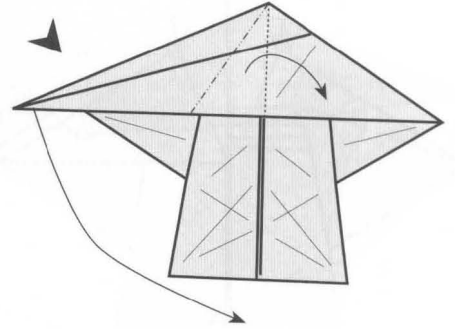

32

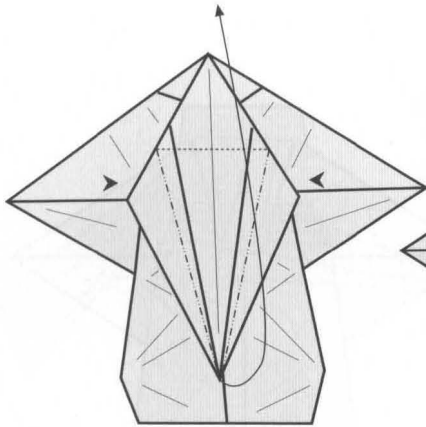

33

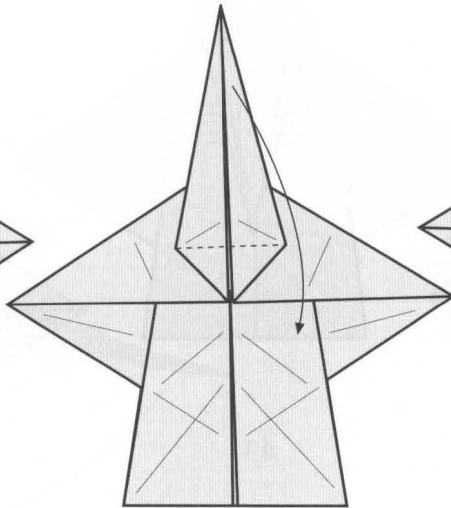

34

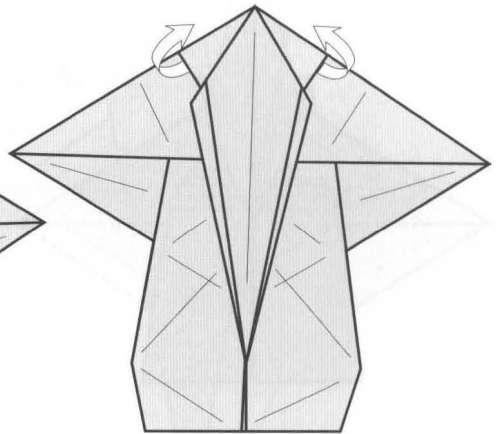

35

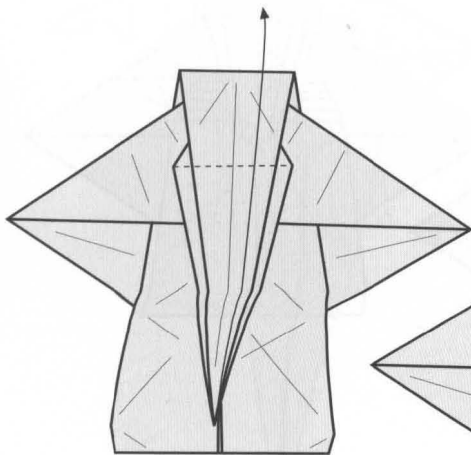

36

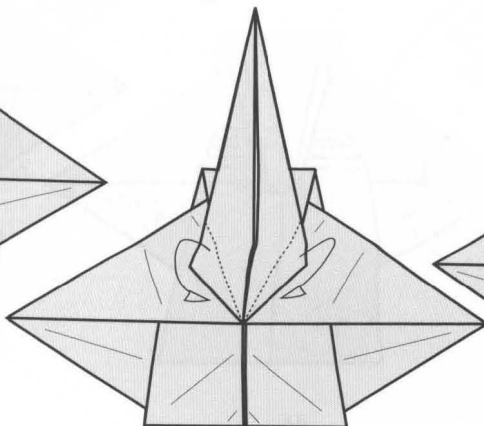

37

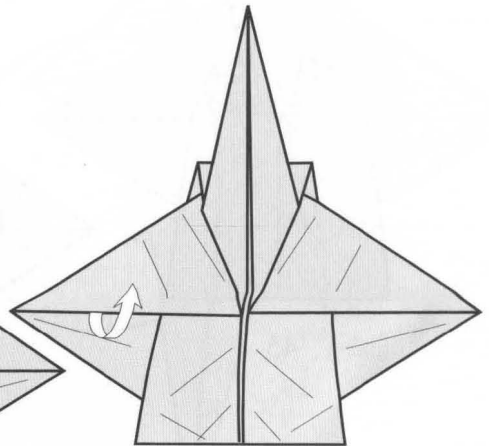

38

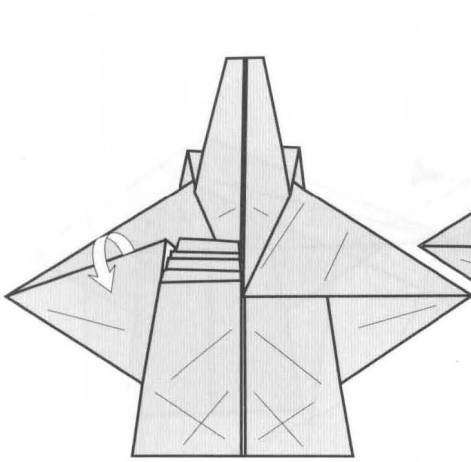

39

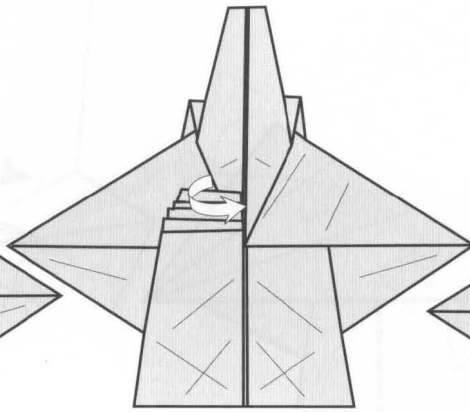

40

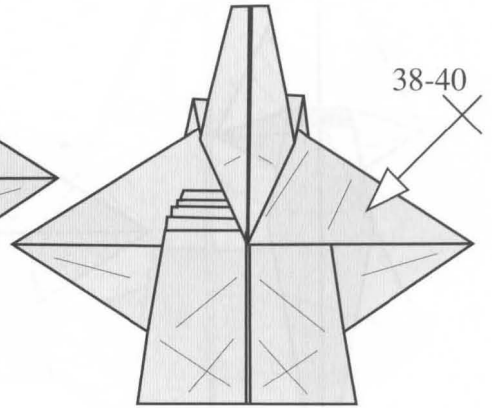

41

38-40

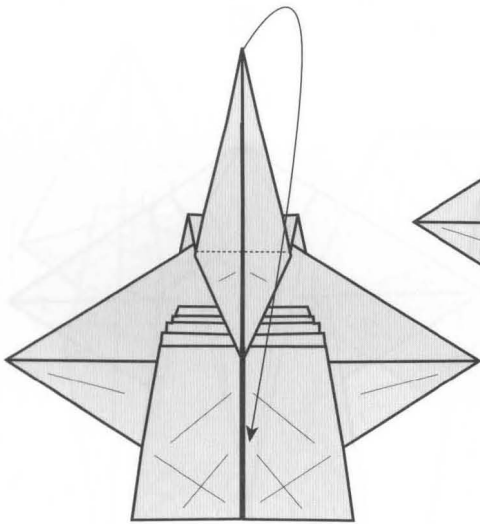

42

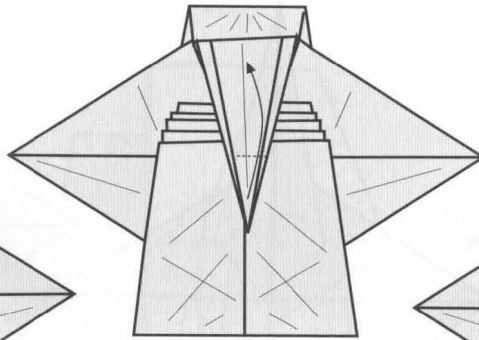

43

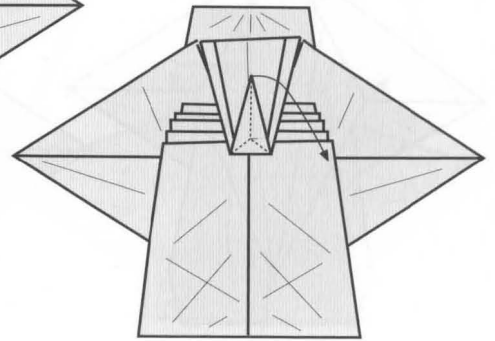

44

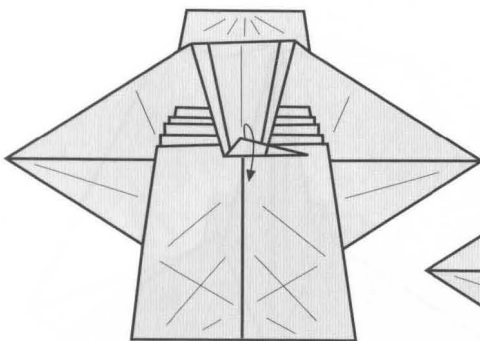

45

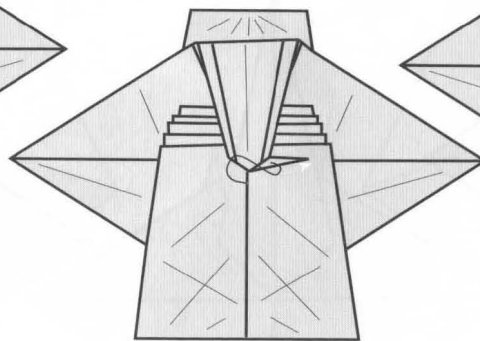

46

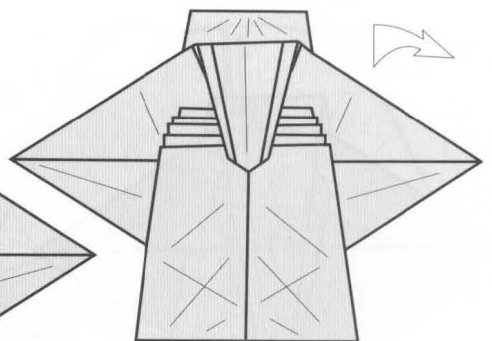

47

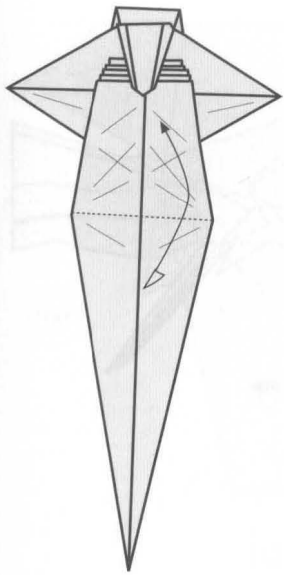

48

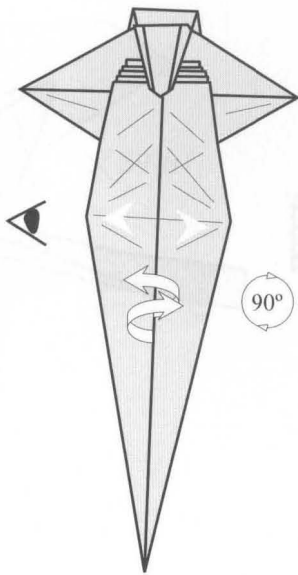

49

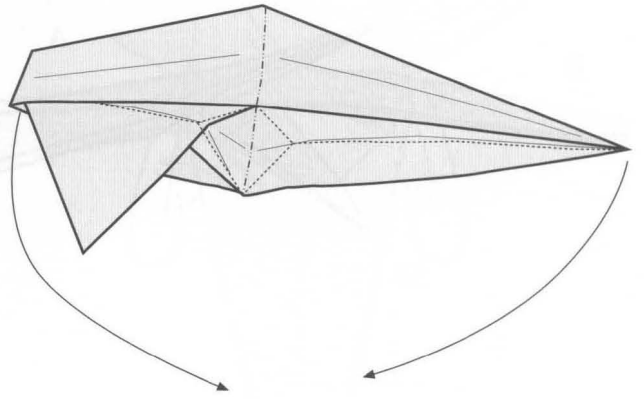

50

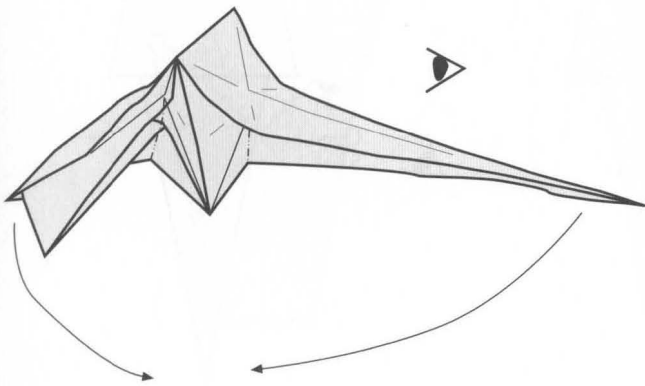

51

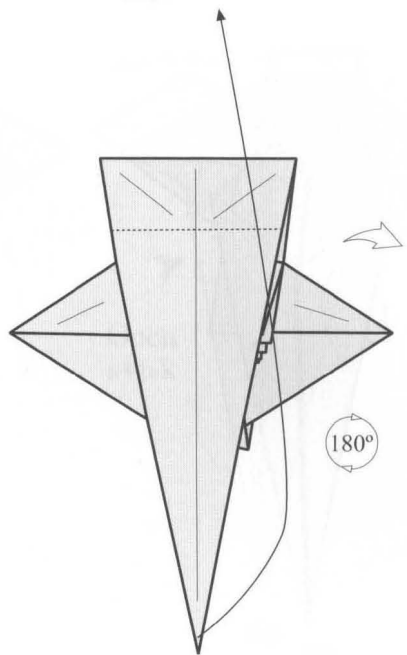

52

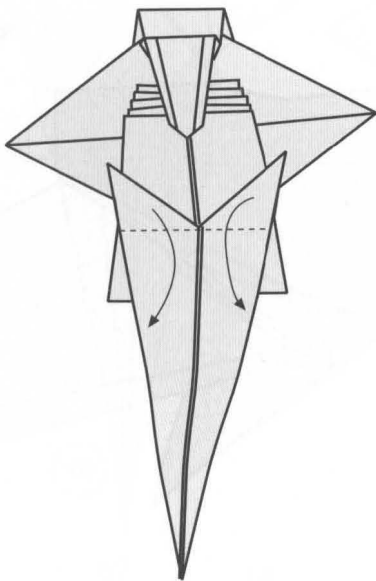

53

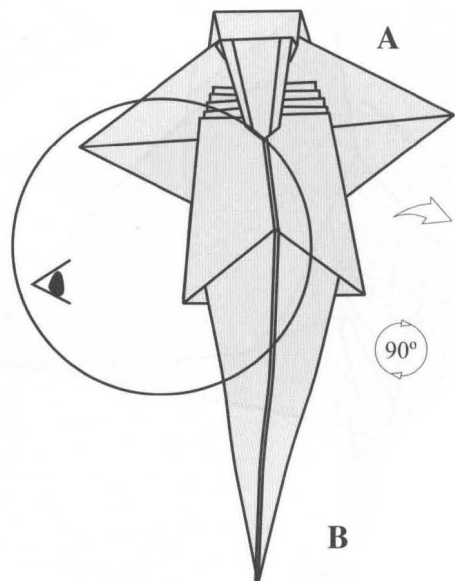

54

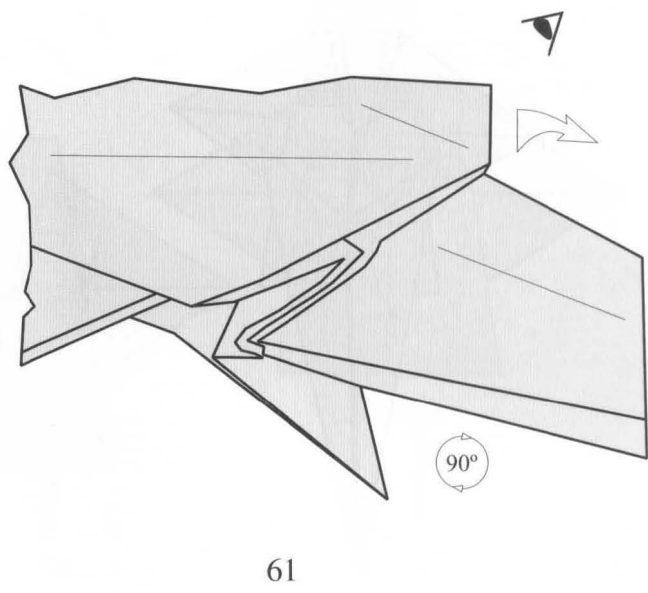
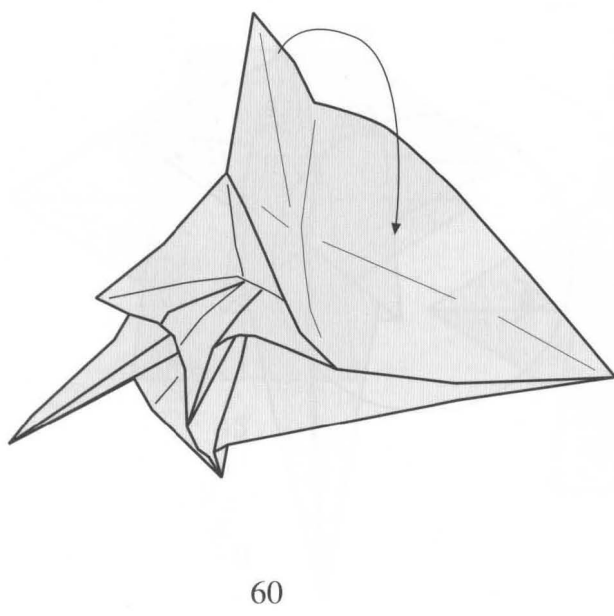
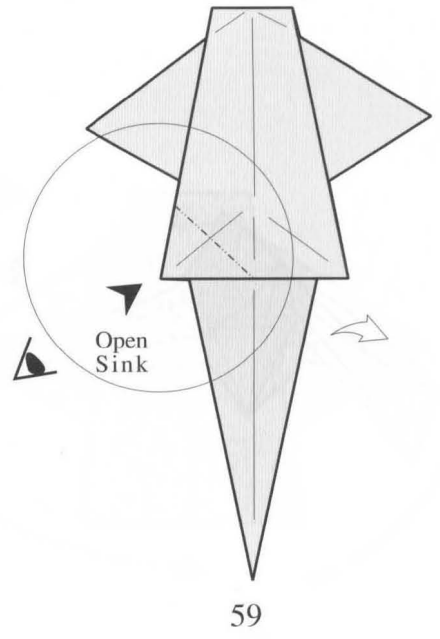
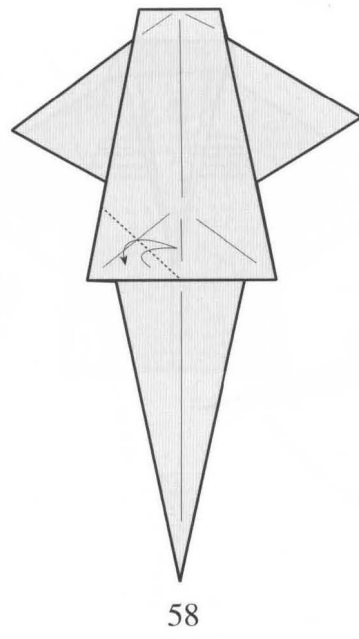
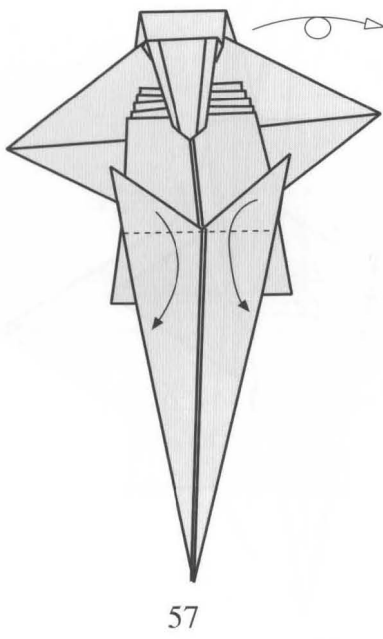
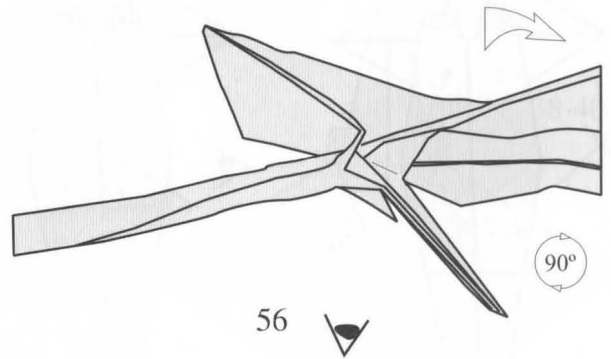
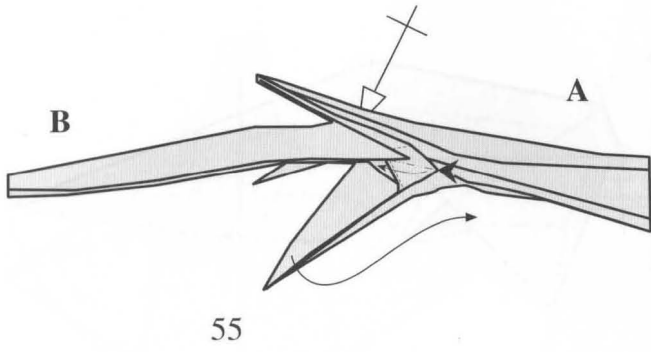

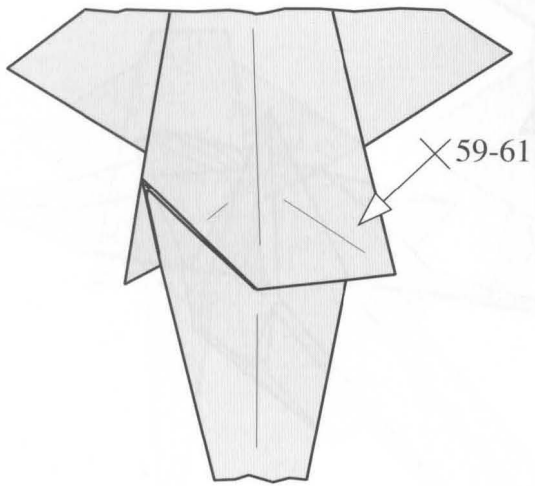

62

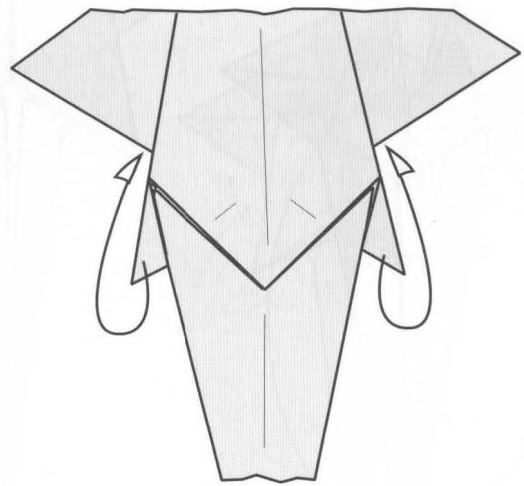

63

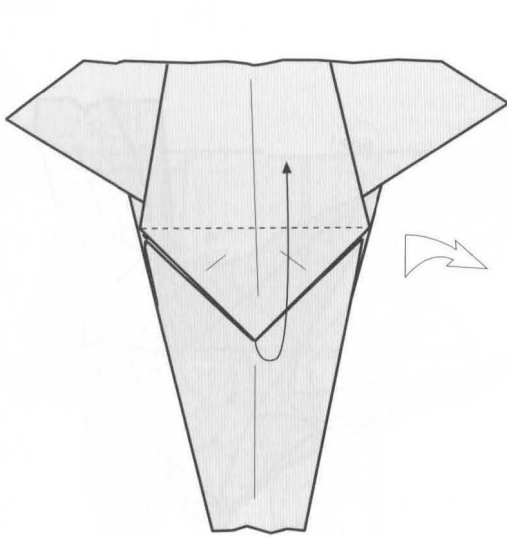

64

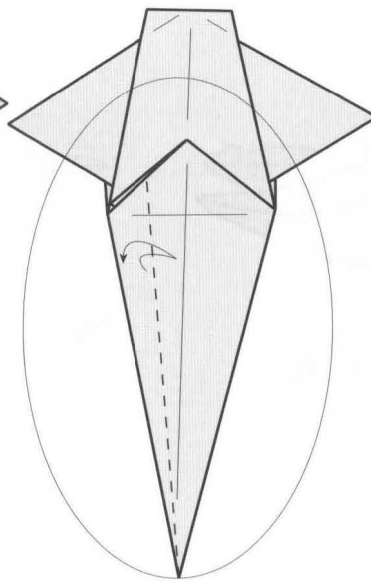

65

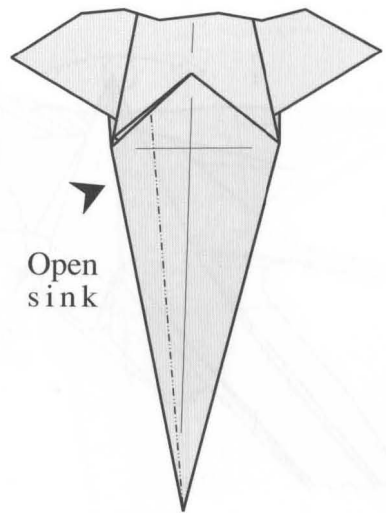

66

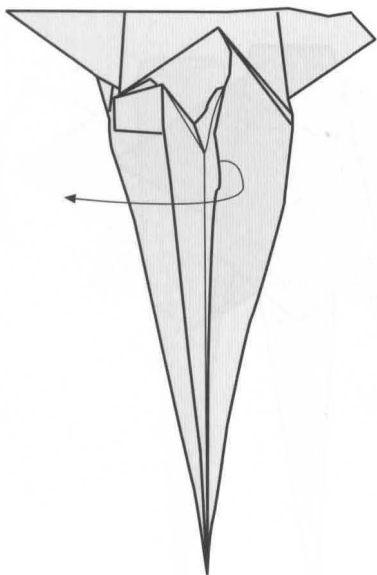

67

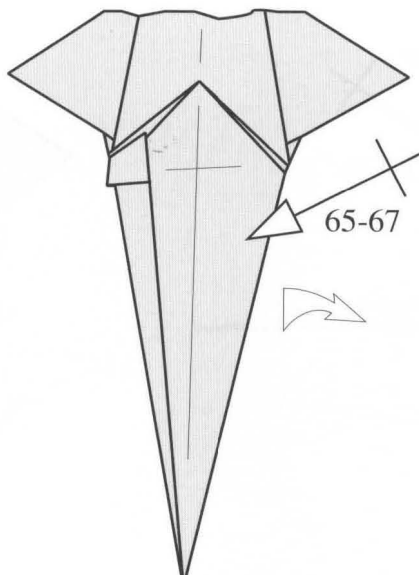

68

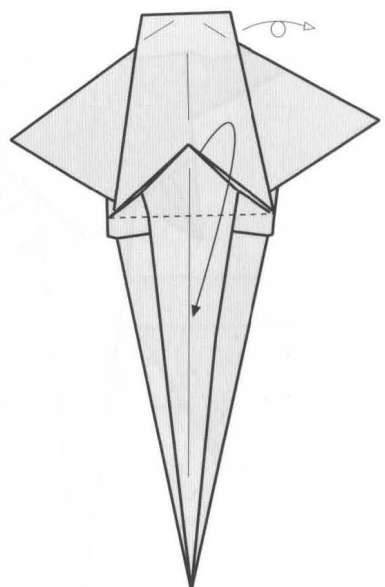

69

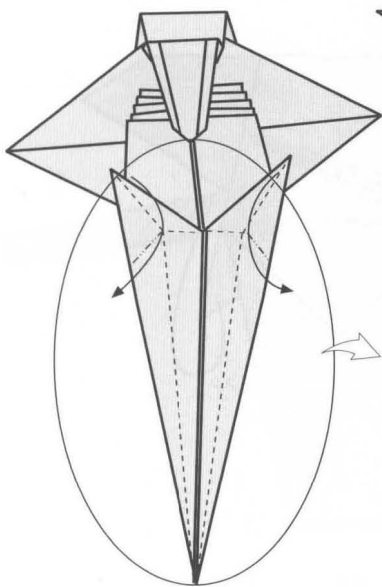

70

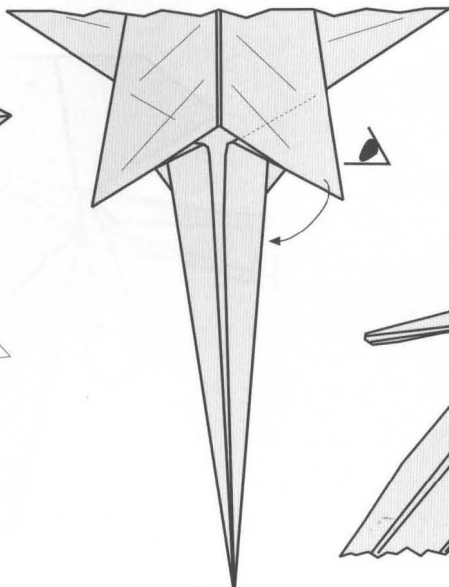

71

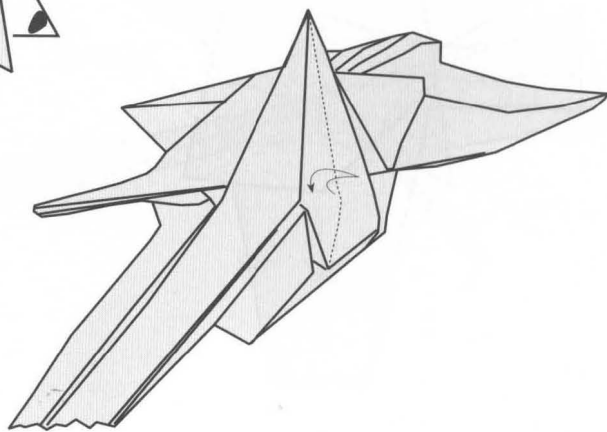

72

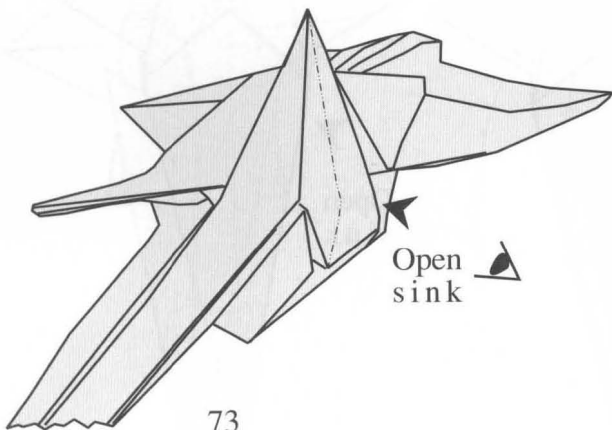

73

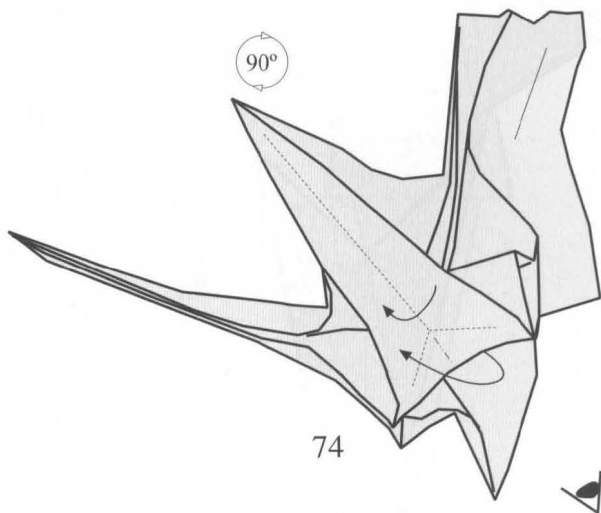

74

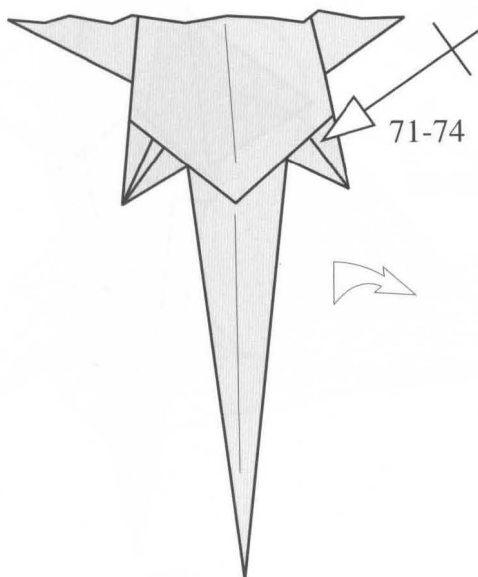

75

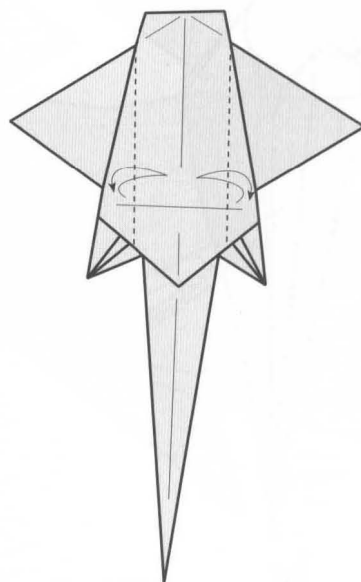

76

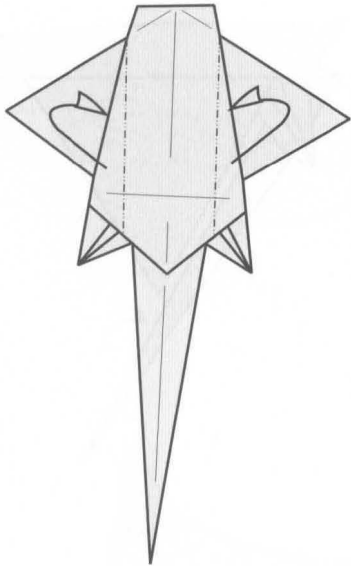

77

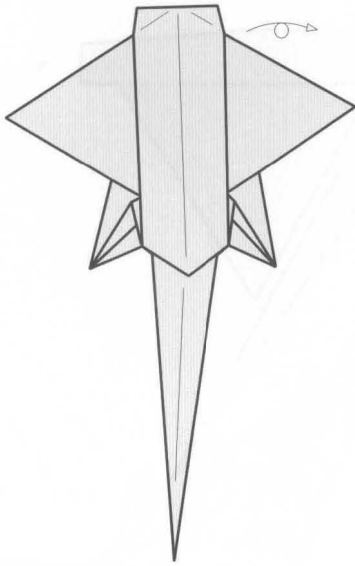

78

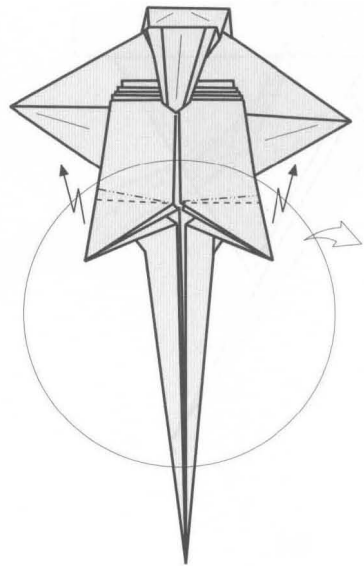

79

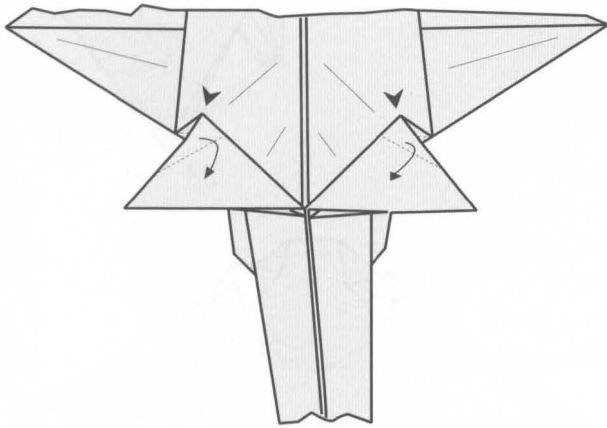

80

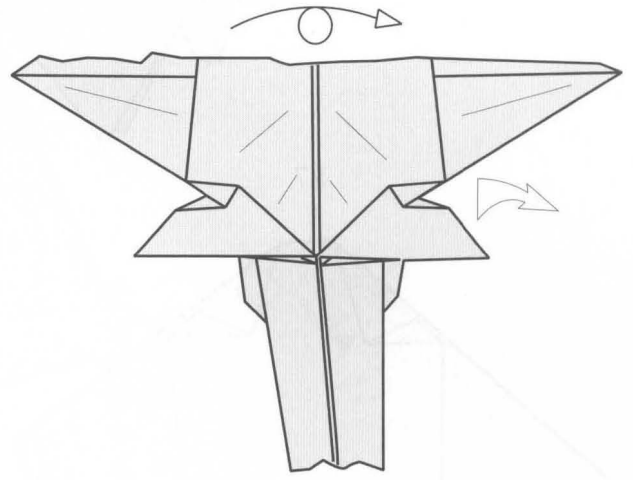

81

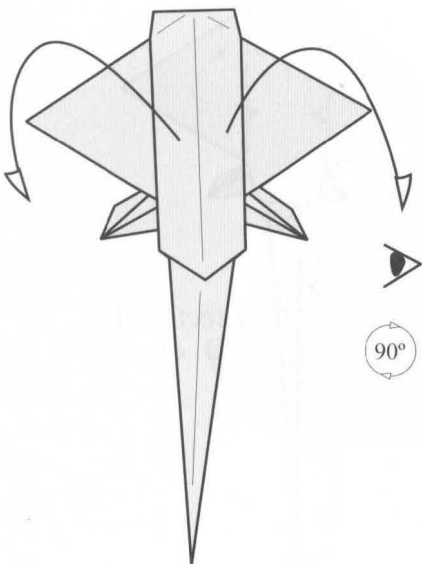

82

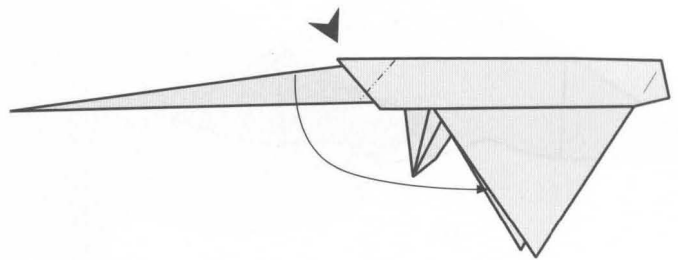

83

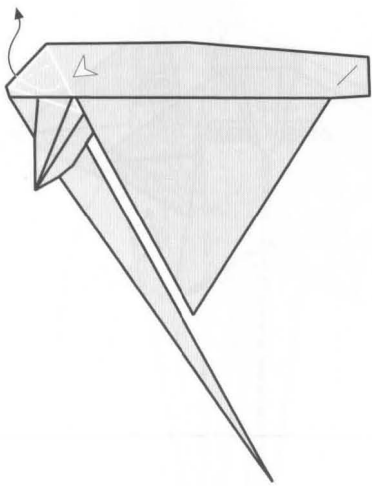

84

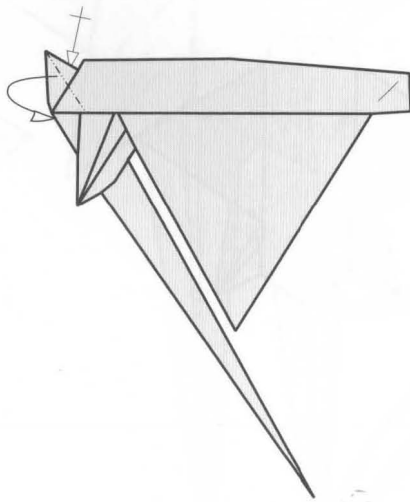

85

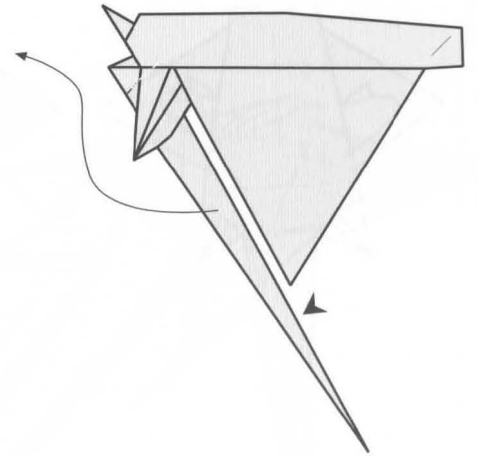

86

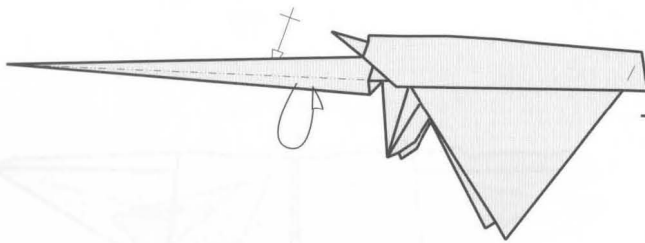

87

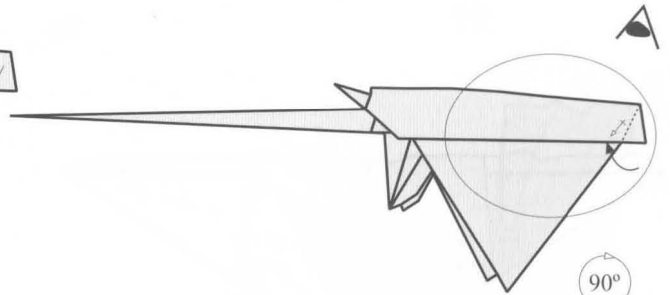

88

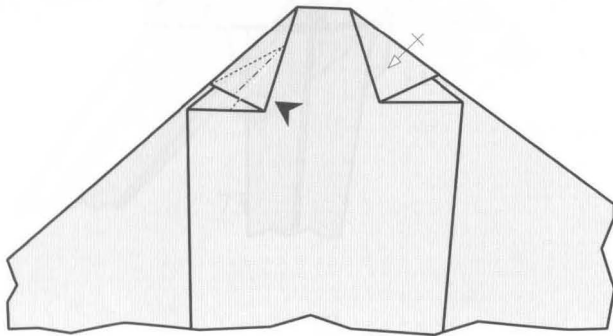

89

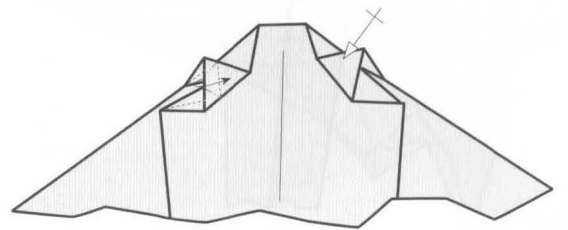

90

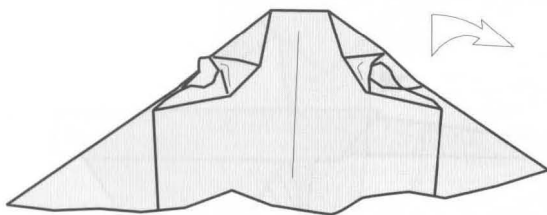

91

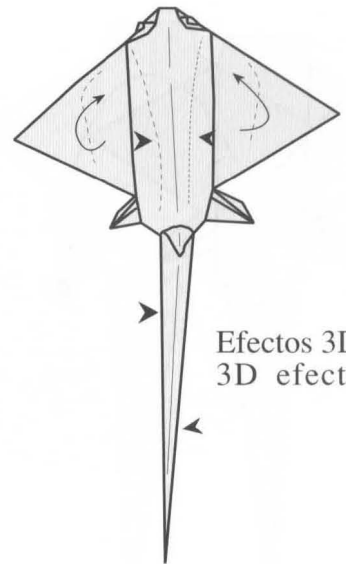

Efectos 3D
3D effects

92

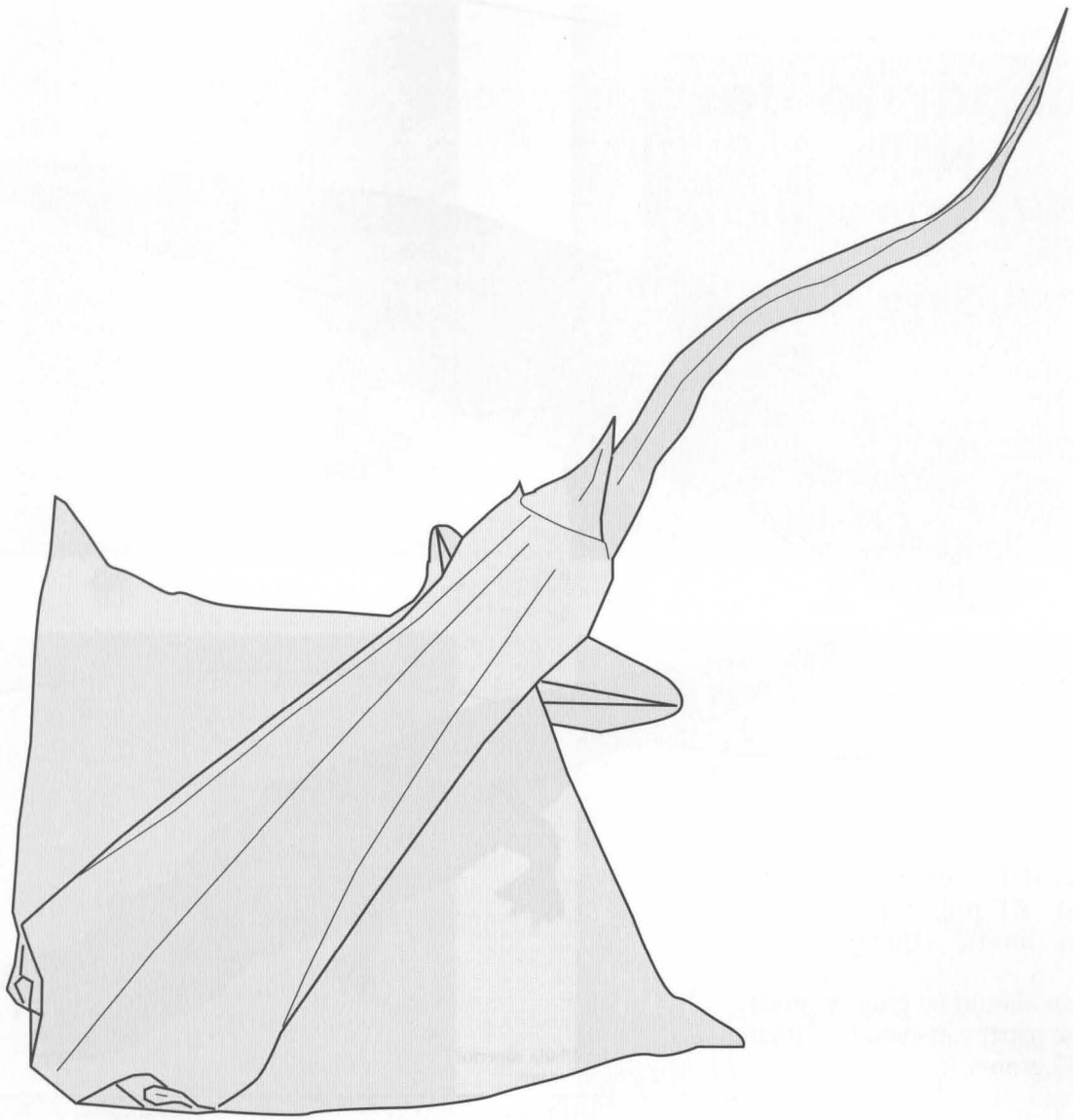

93

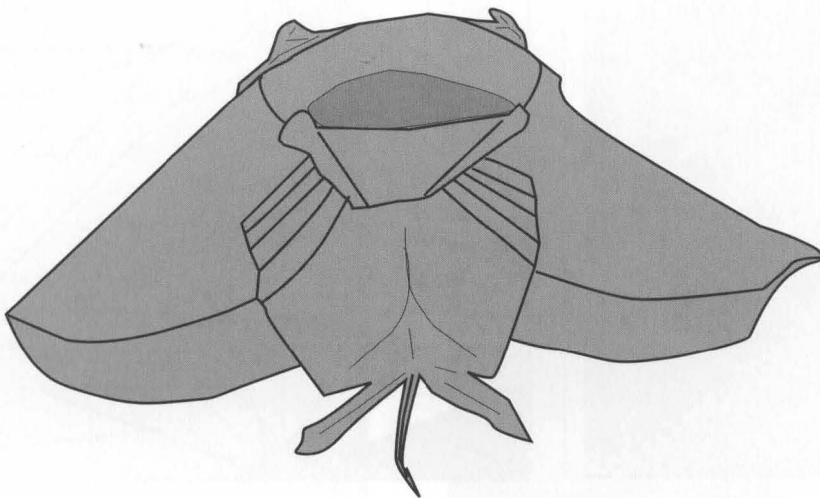

Cocodrilo del Nilo

Nile crocodile

© M. Sirgo - 2005



El papel debe ser gris o verde obscuro. El papel puede ser variado hasta 100 gramos.

The paper should be gray or green dark. The paper can even be varied until 100 grams.

0.7

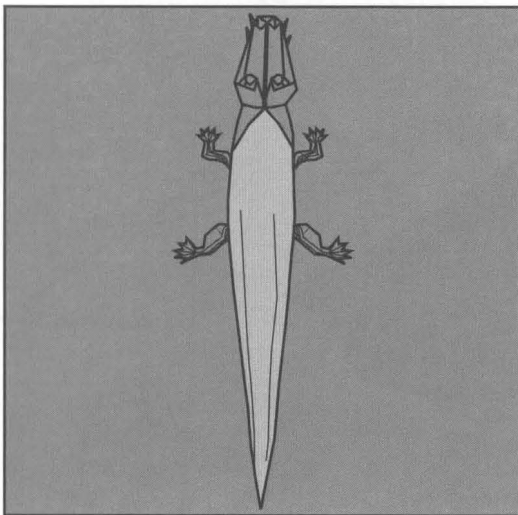

Mandíbula superior
superior jaw

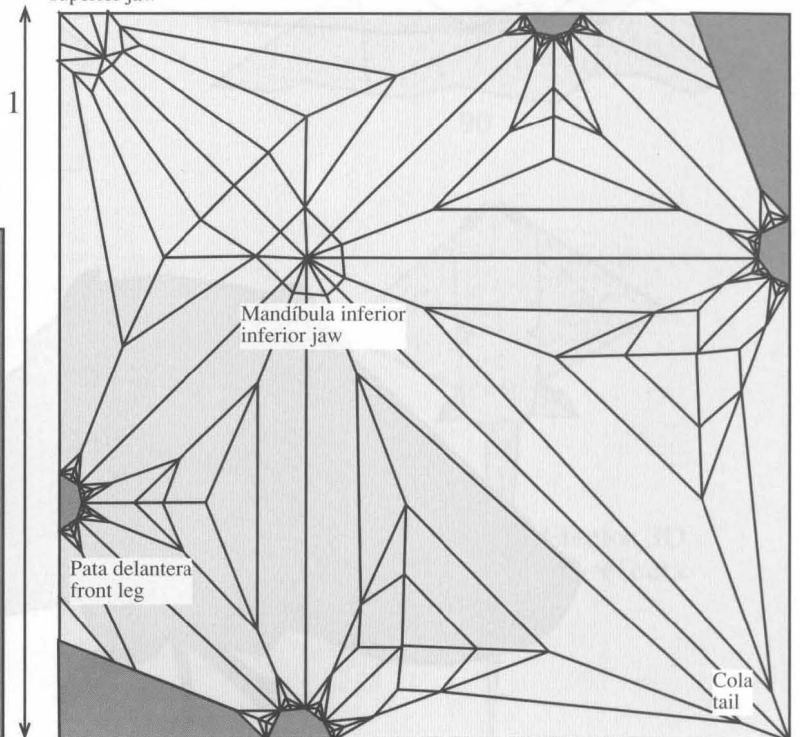

Mandíbula inferior
inferior jaw

Pata delantera
front leg

Cola
tail

Pata trasera
back leg

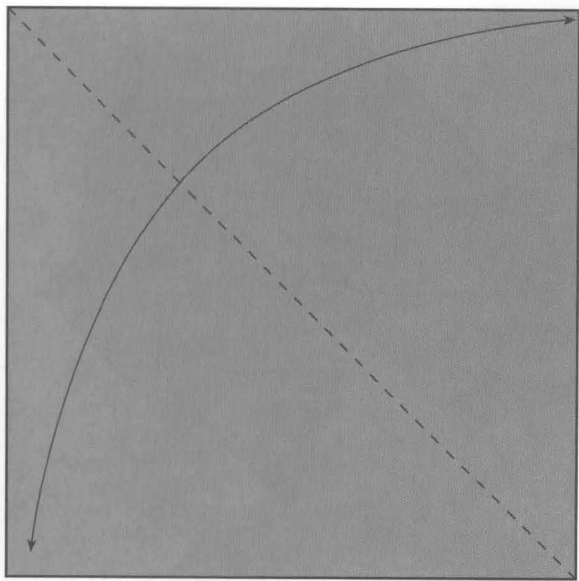

1 ●

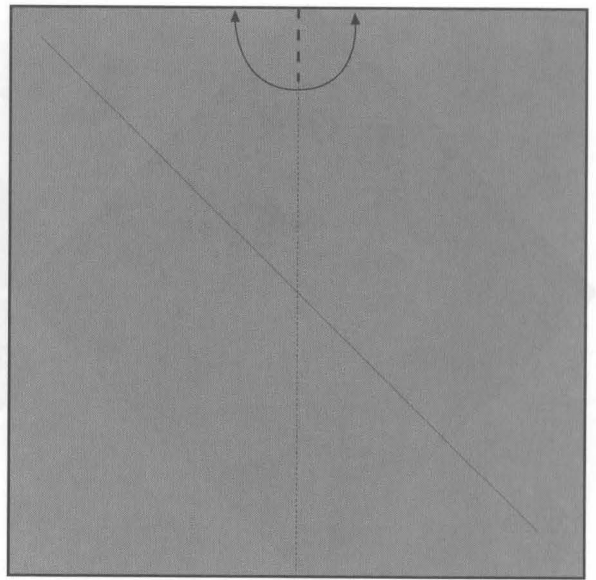

2

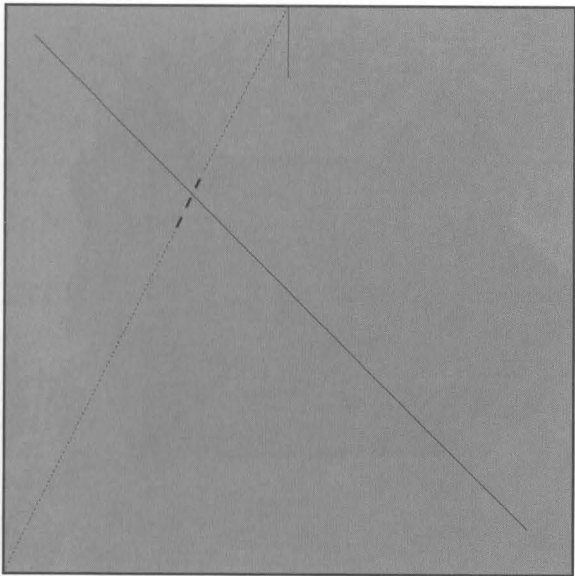

3

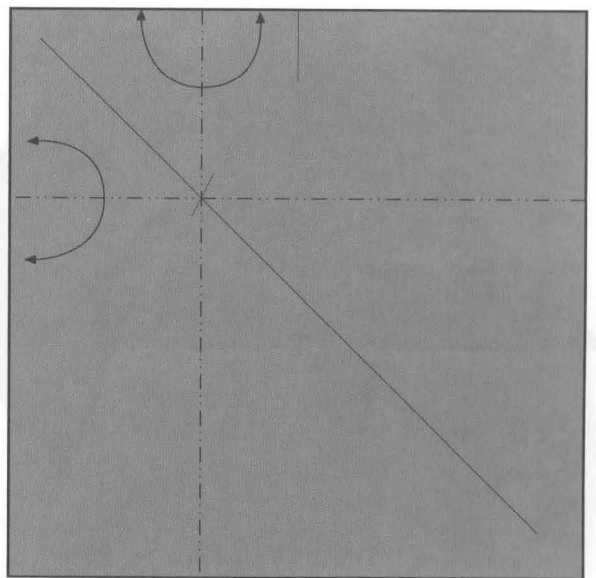

4

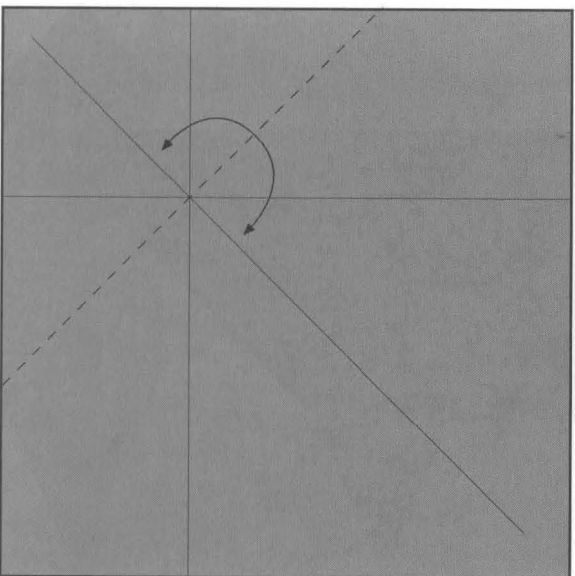

5

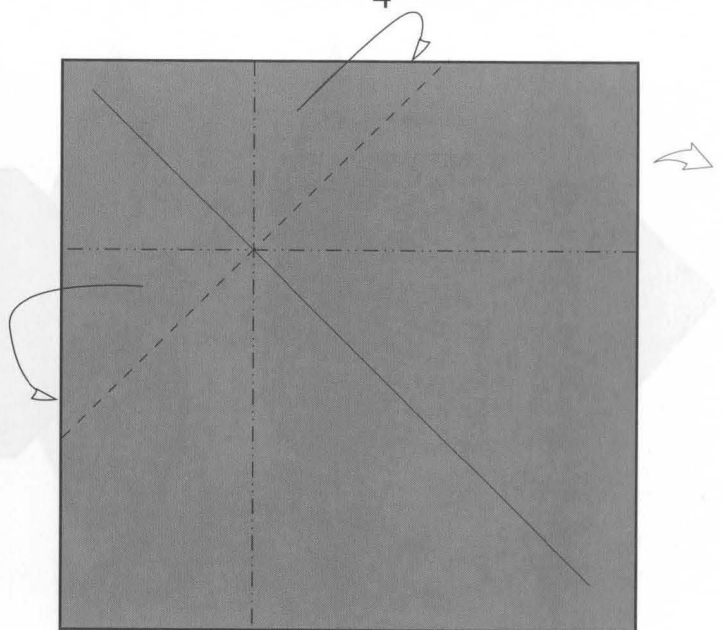

6

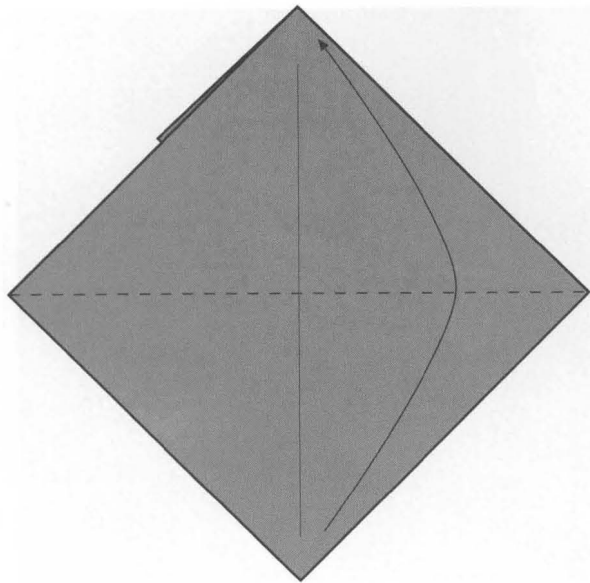

7

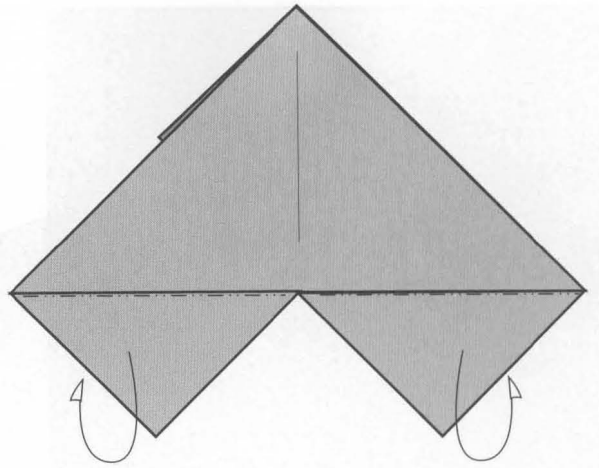

8

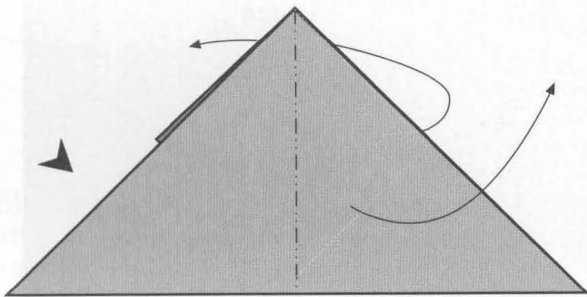

9

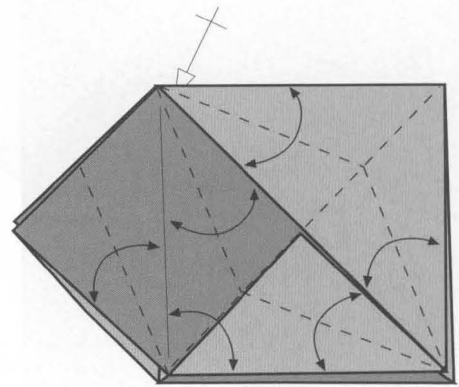

10

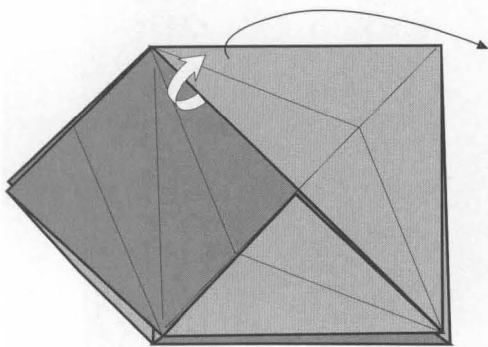

11

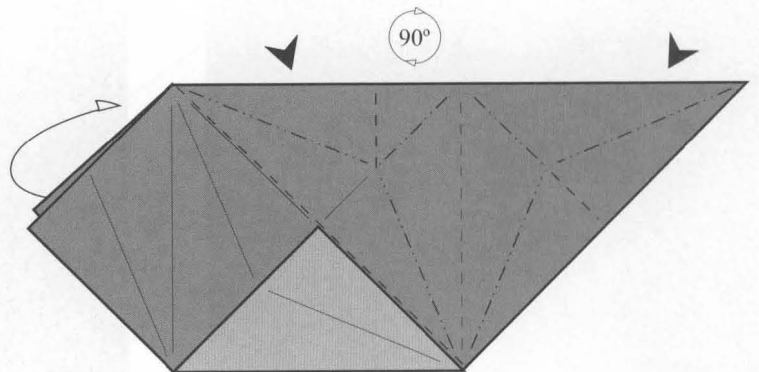

12

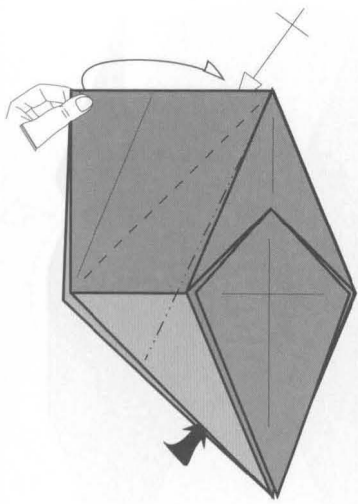

13

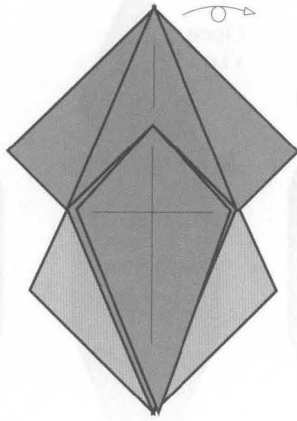

14

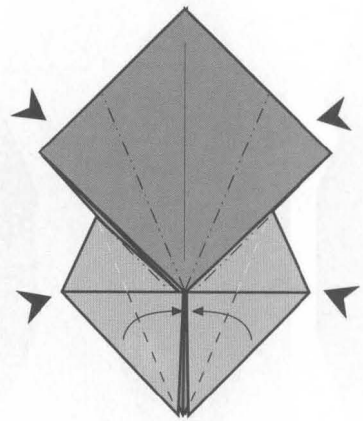

15

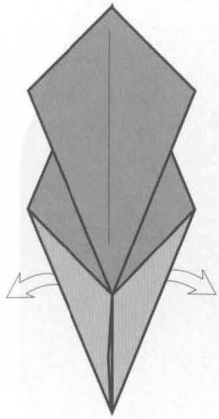

16

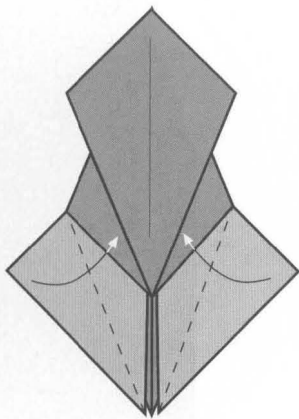

17

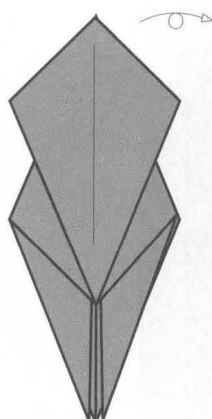

18

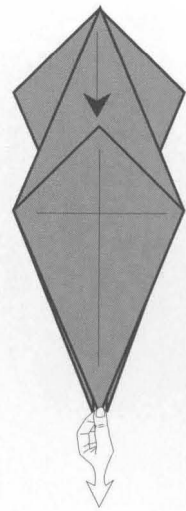

19

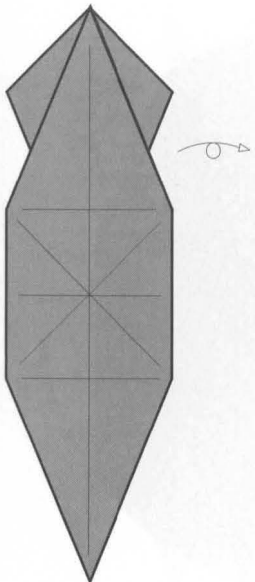

20

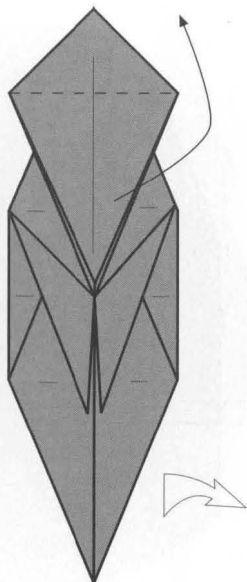

21

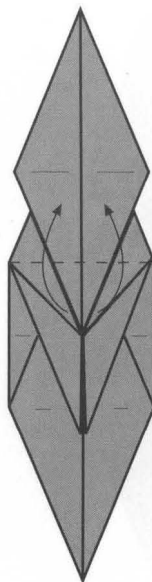

22

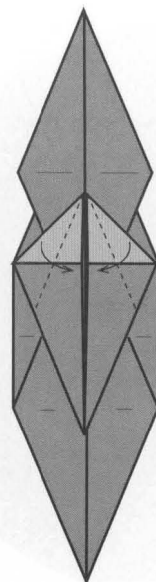

23

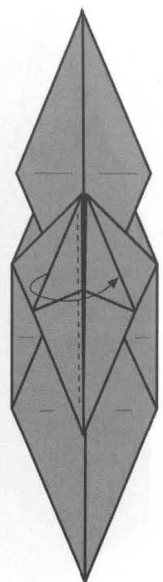

24

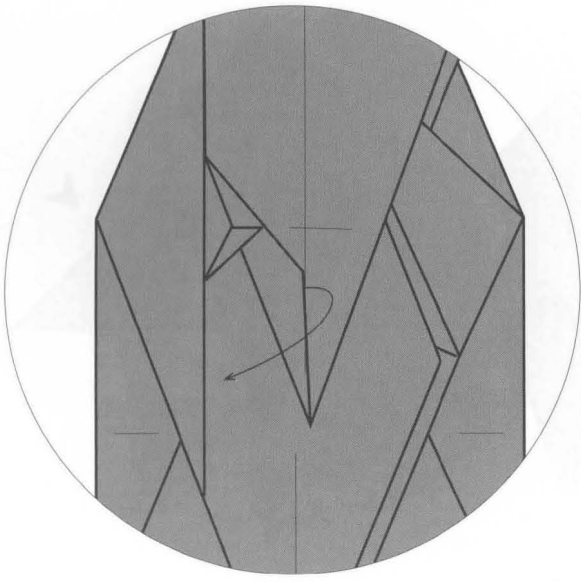
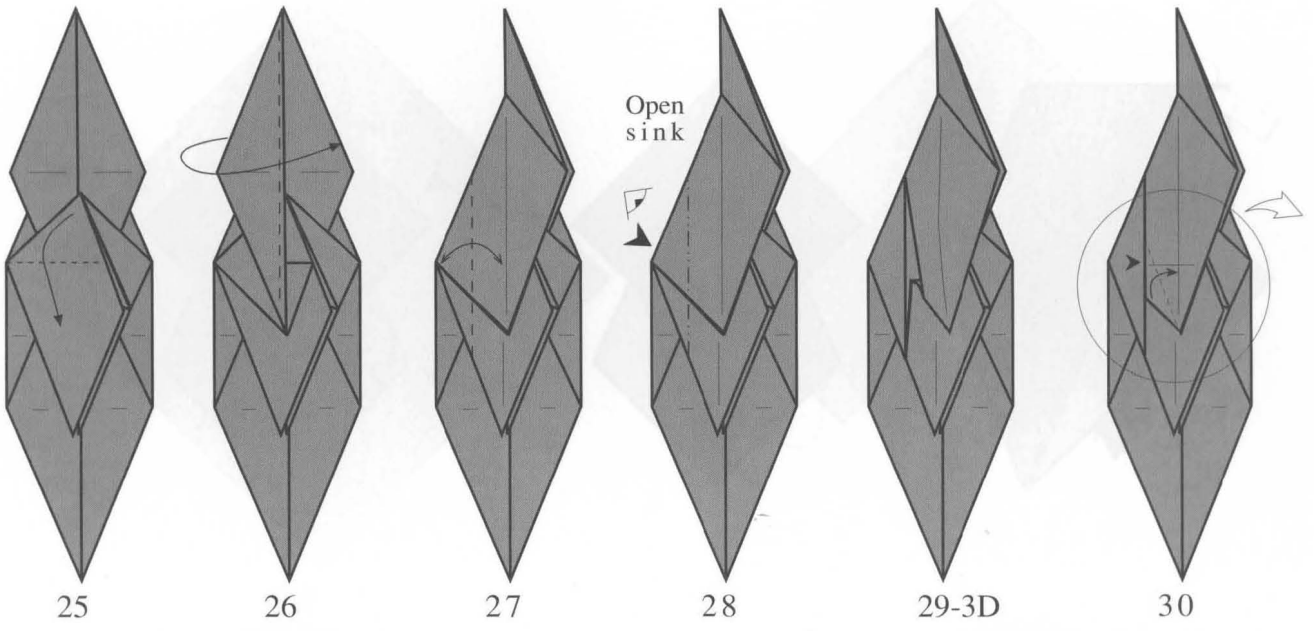

31

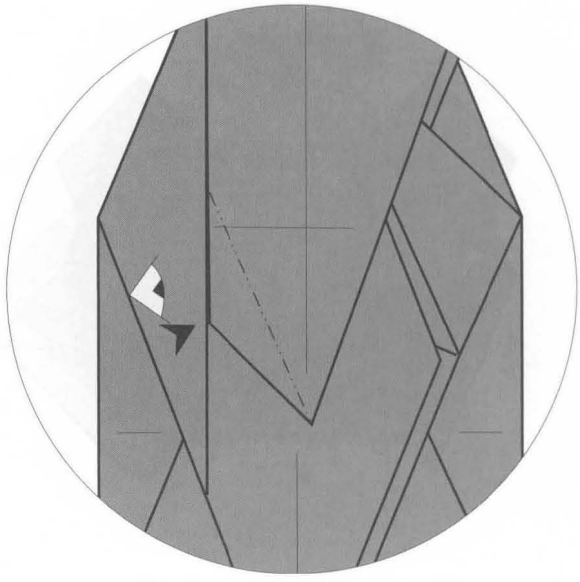

32-Open sink



33-3D

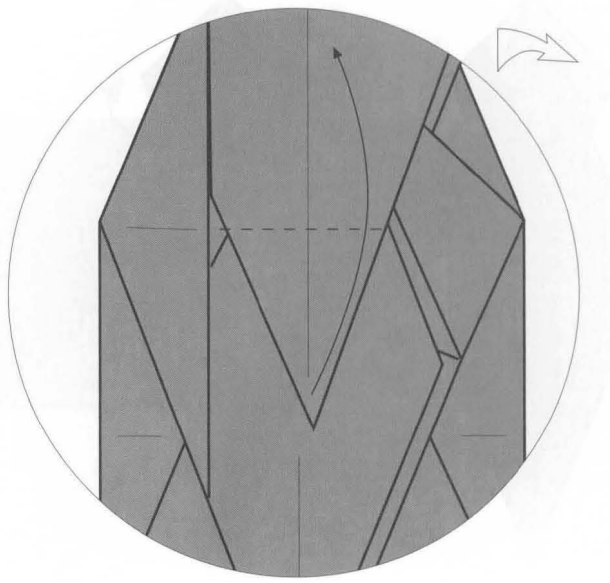

34

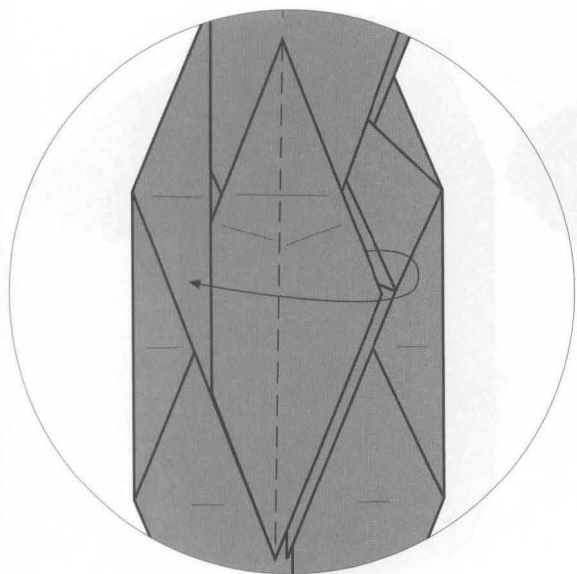

35

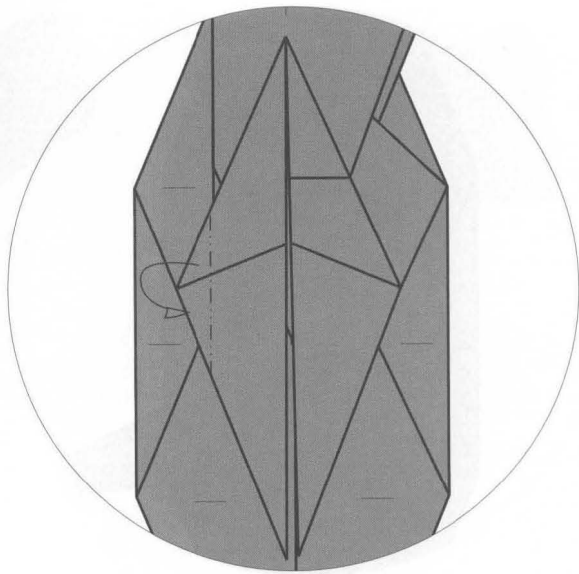

36

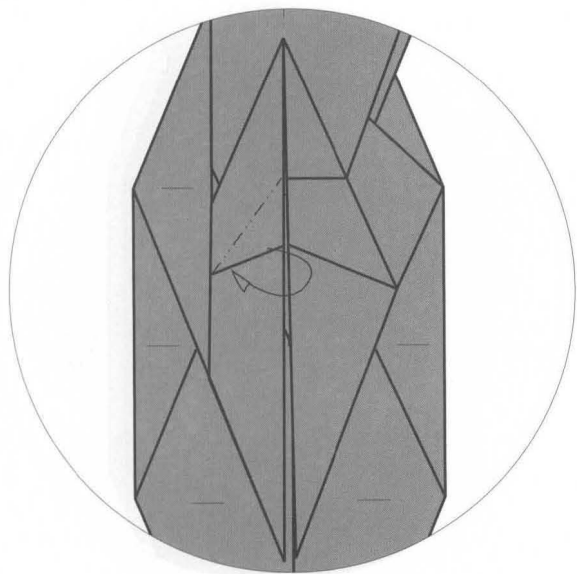

37

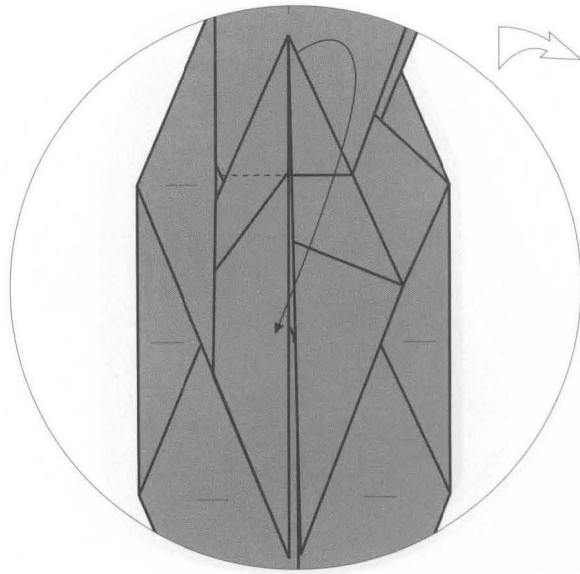

38

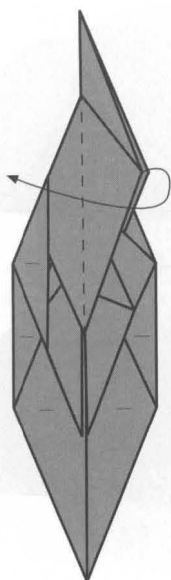

39

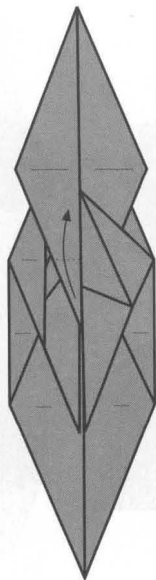

40

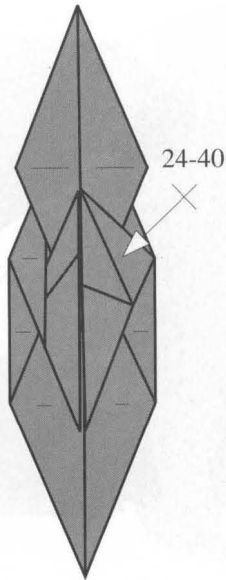

41

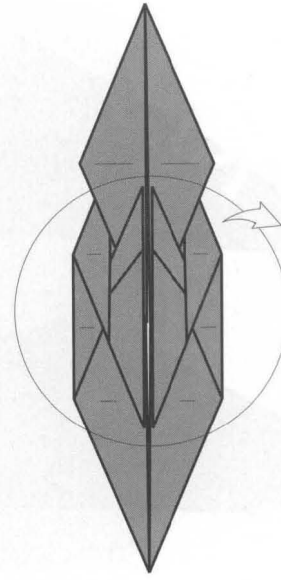

42

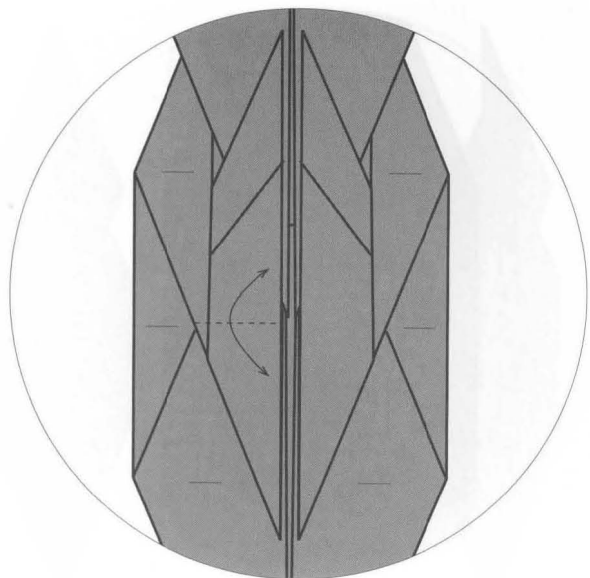

43

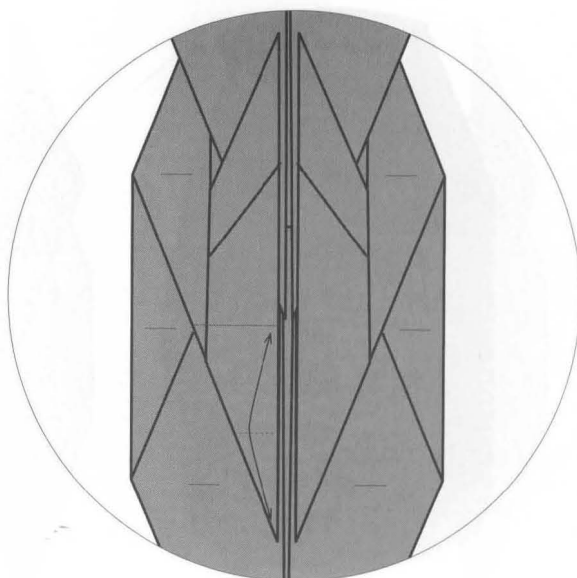

44

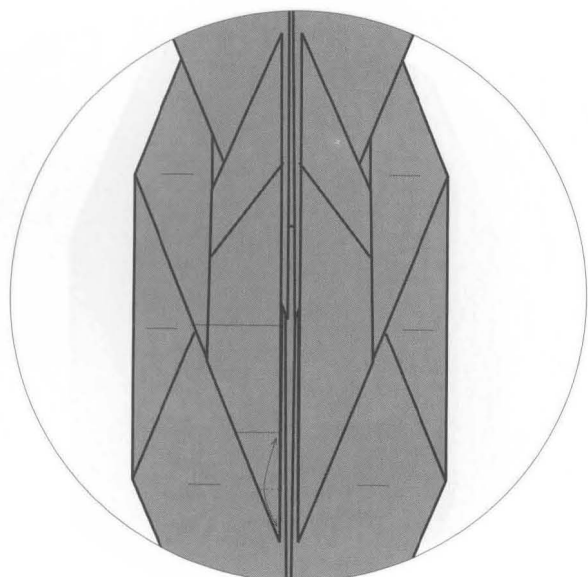

45

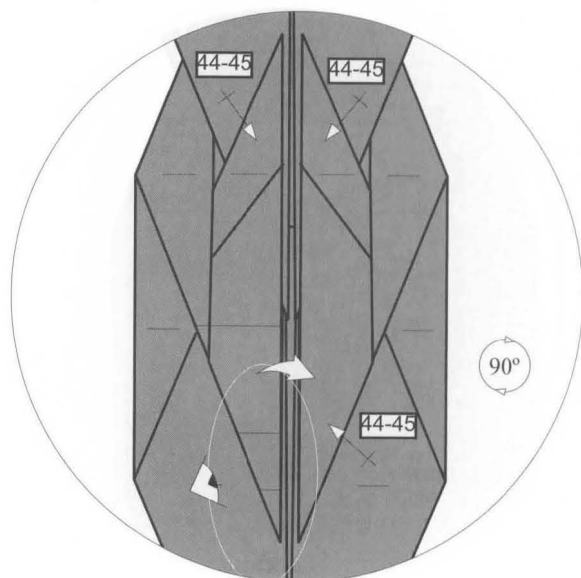

46

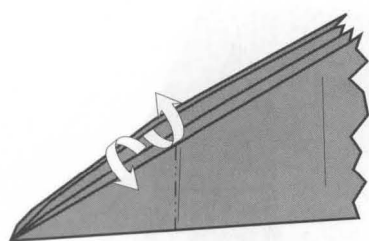

47

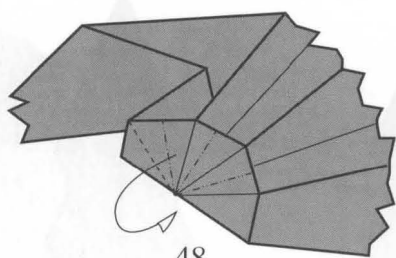

48

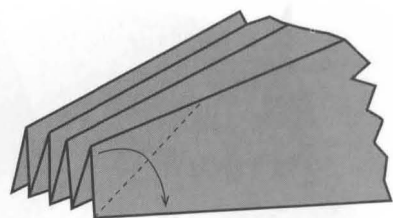

49

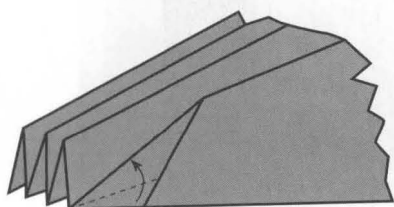

50

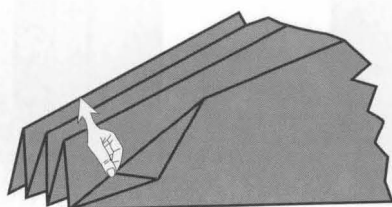

51

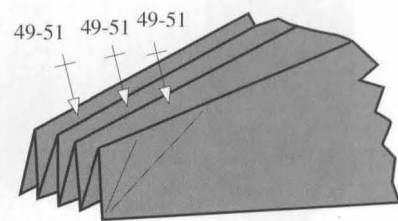

52

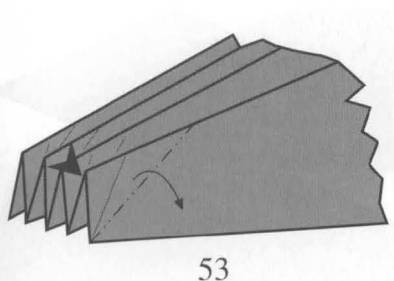

53

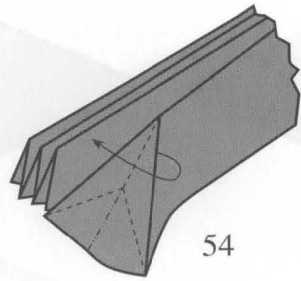

54

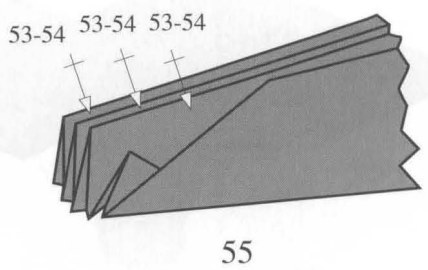

55

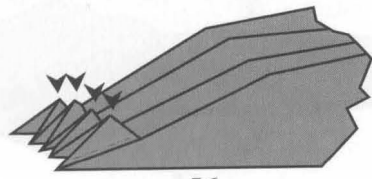

56

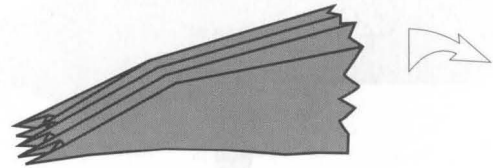

57

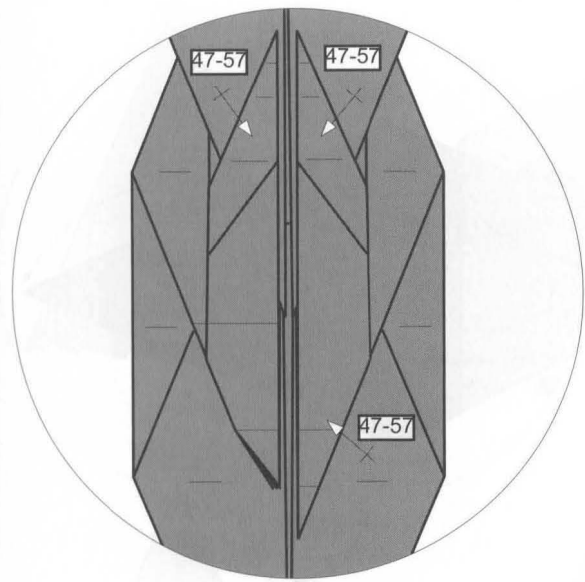

58

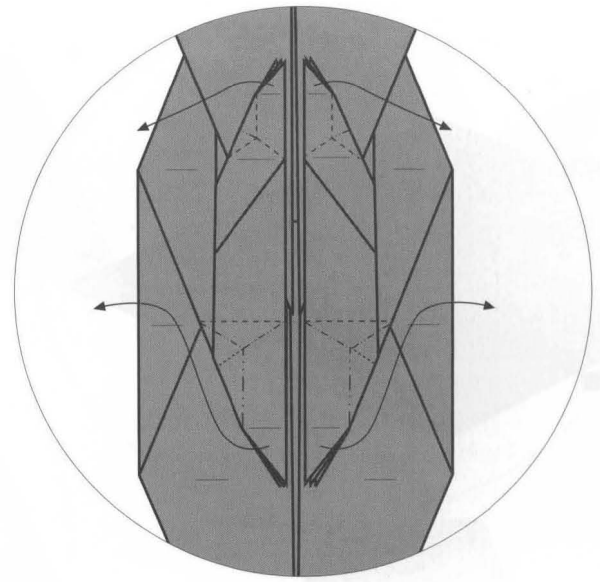

59

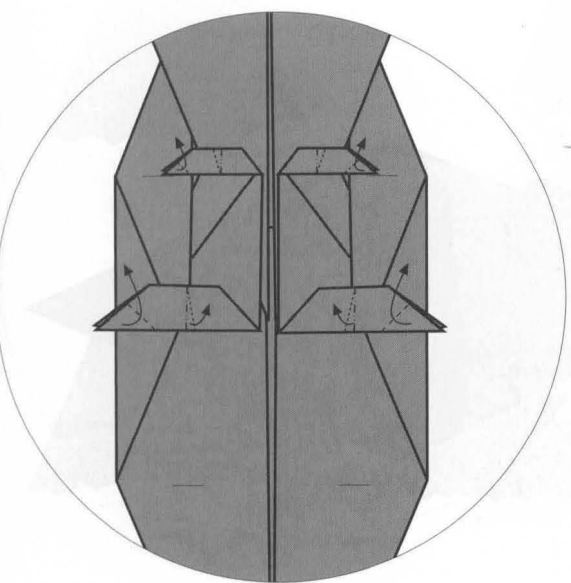

60

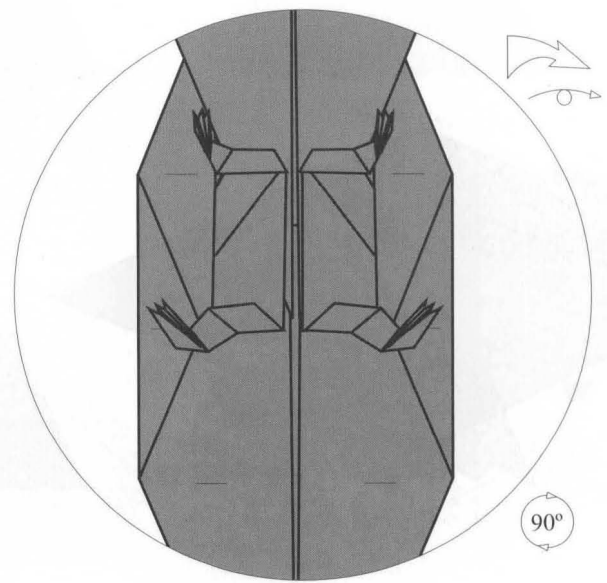

61

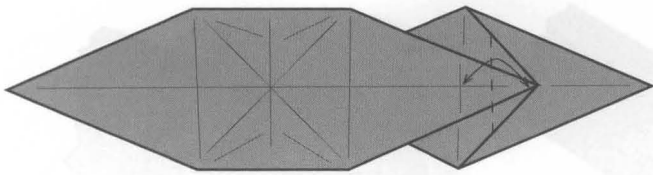

62

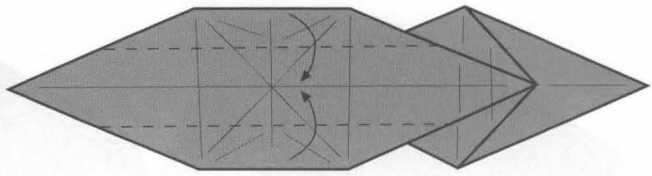

63

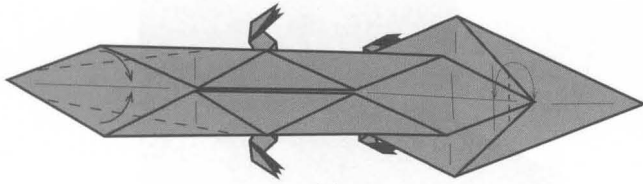

64

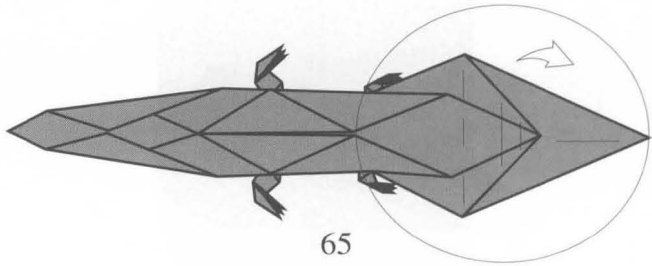

65

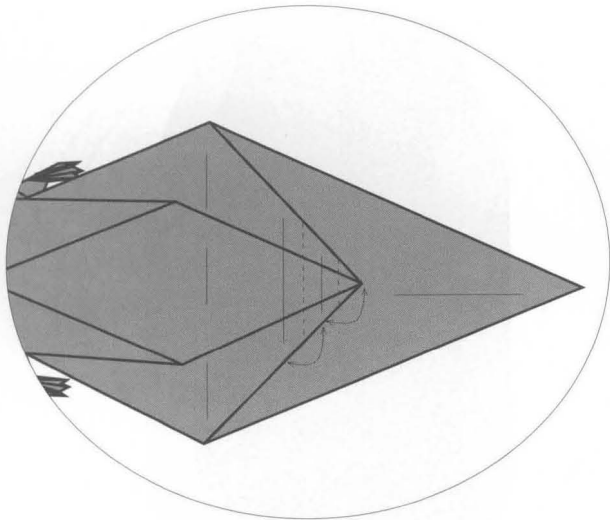

66

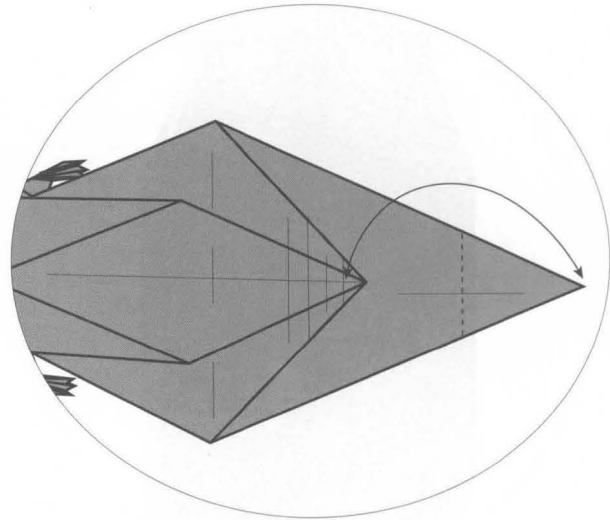

67

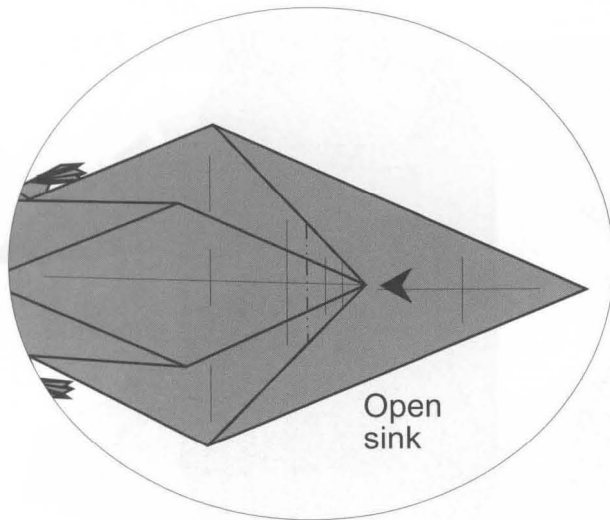

Open
sink

68

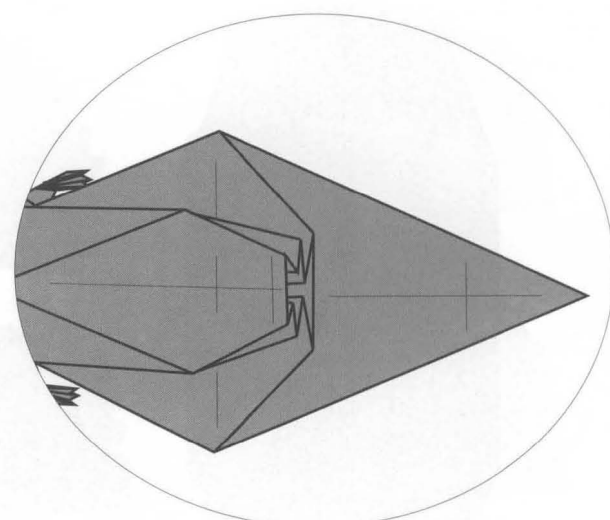

69 -3D

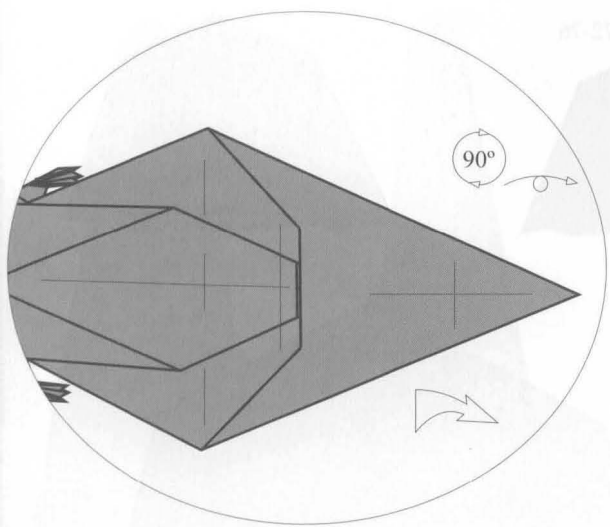

70

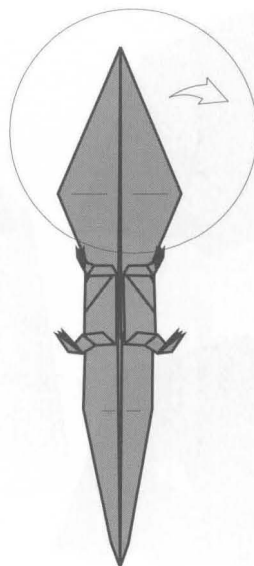

71

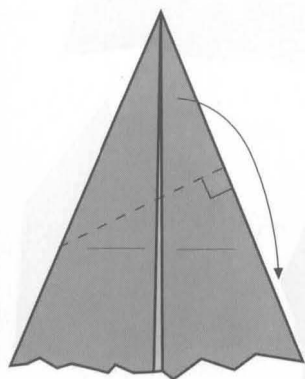

72

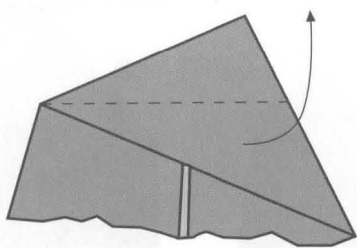

73

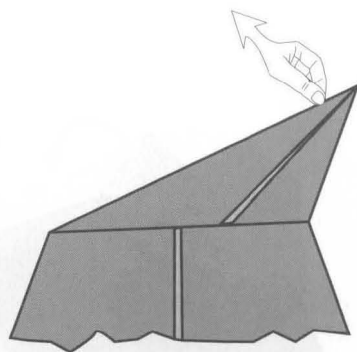

74

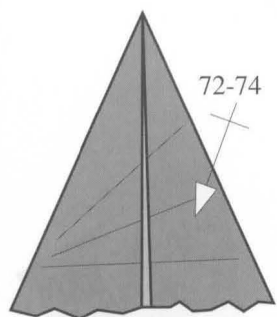

75

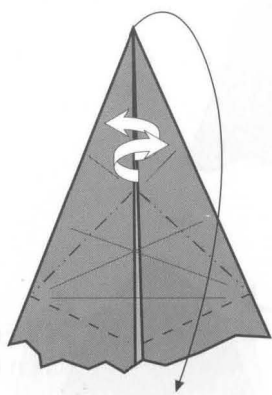

76

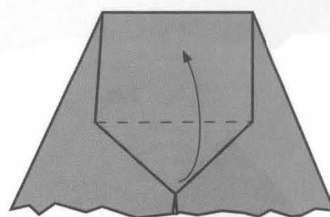

77

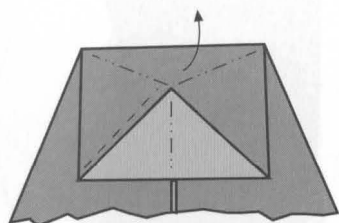

78

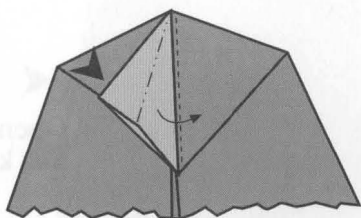

79

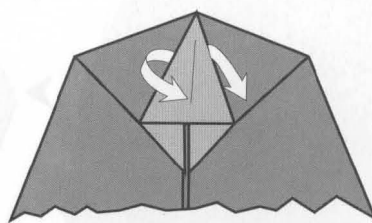

80

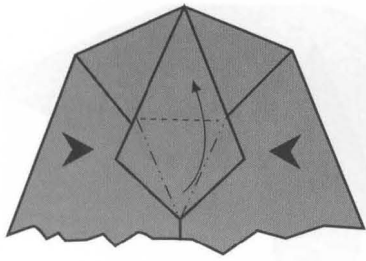

81

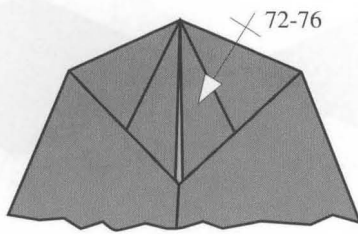

82

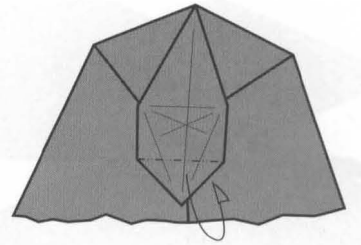

83

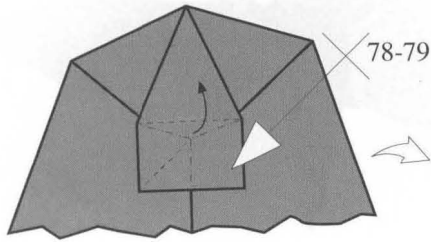

84

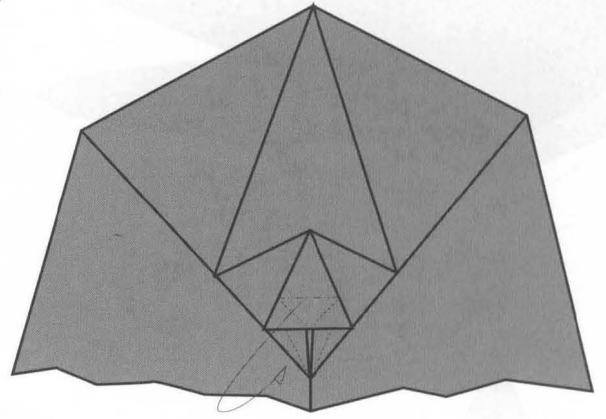

85

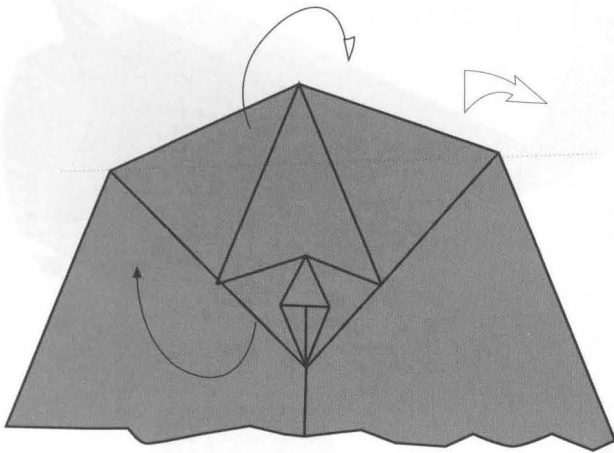

86

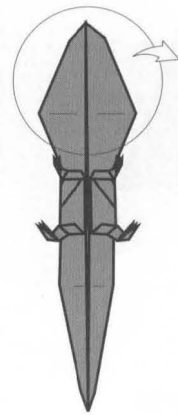

87

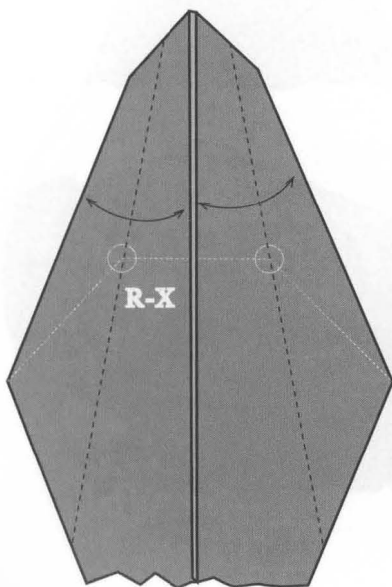

88

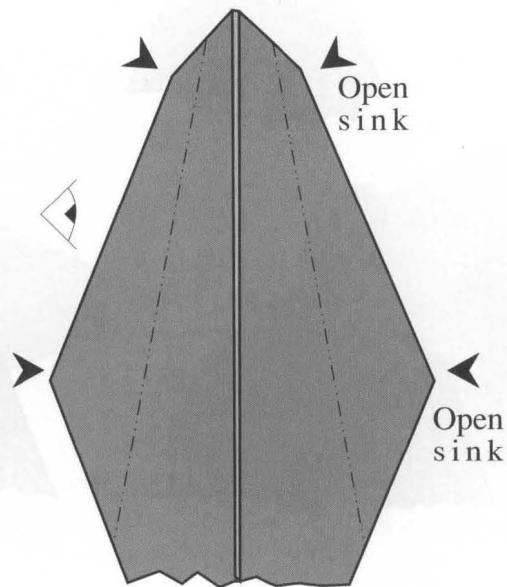

89

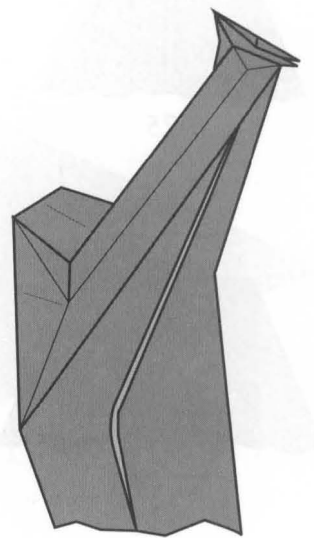

90-3D

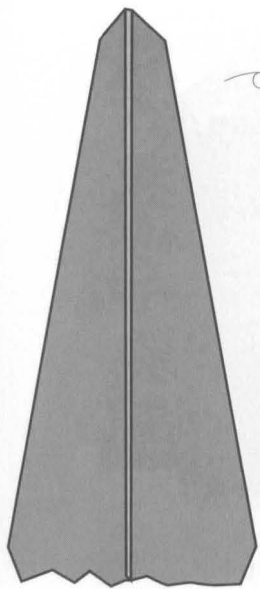

91

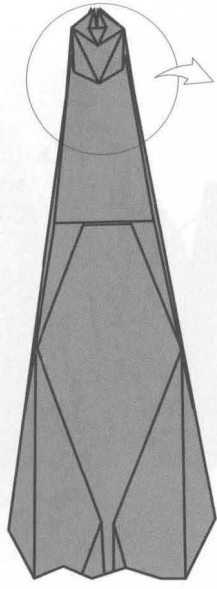

92

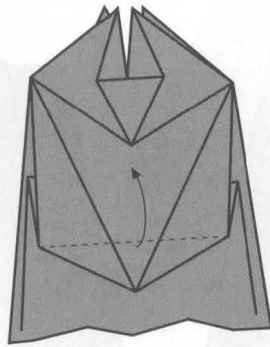

93

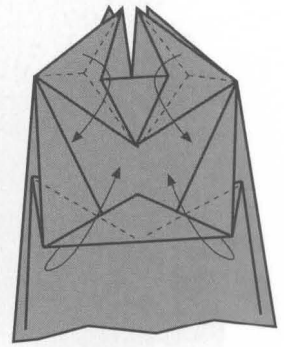

94

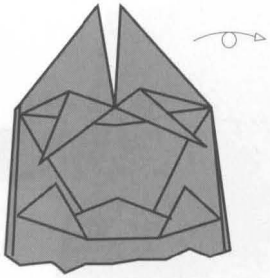

95

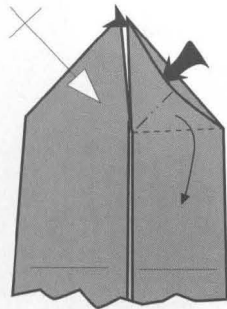

96

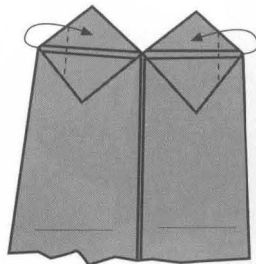

97

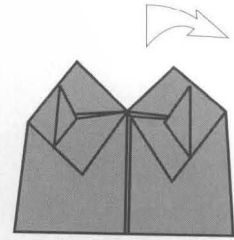

98

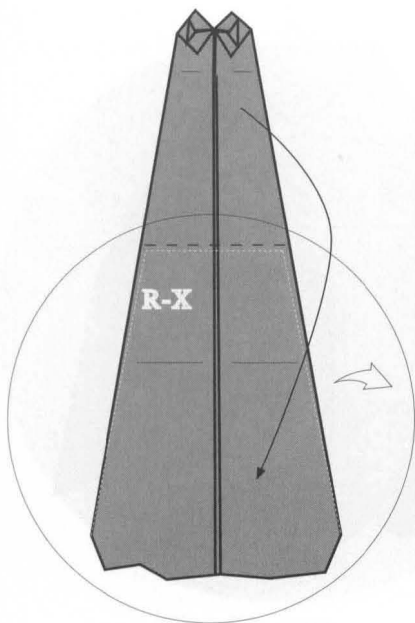

99

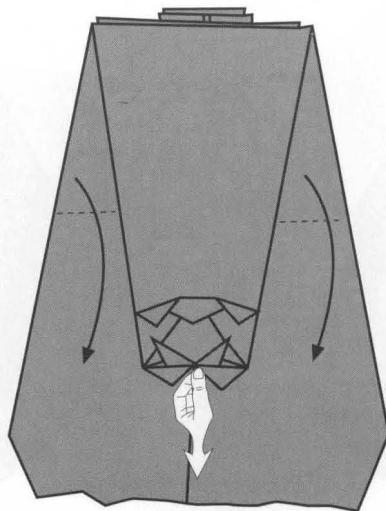

100

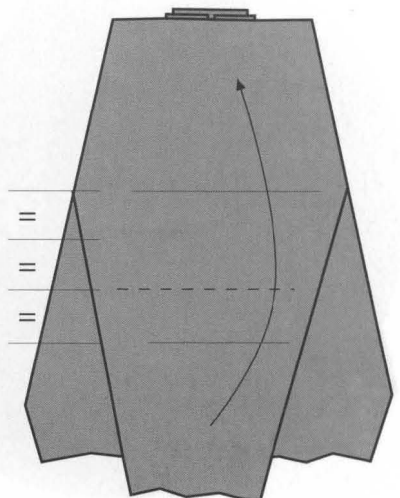

101

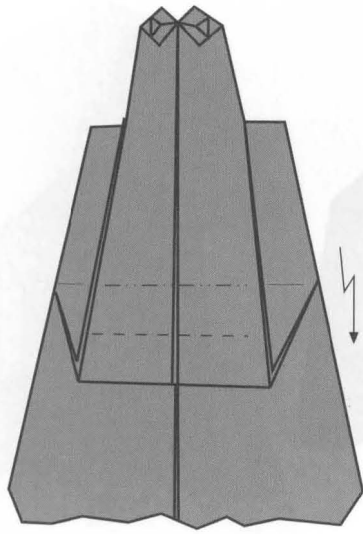

102

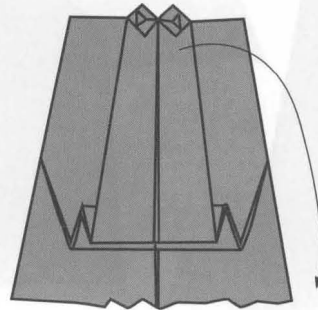

103

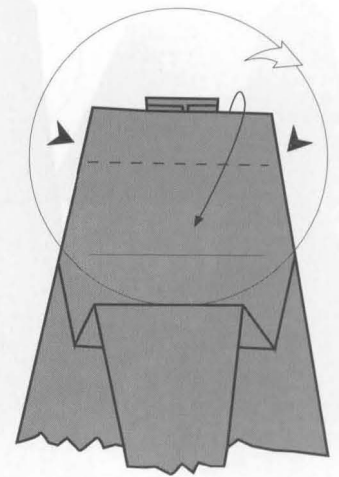

104

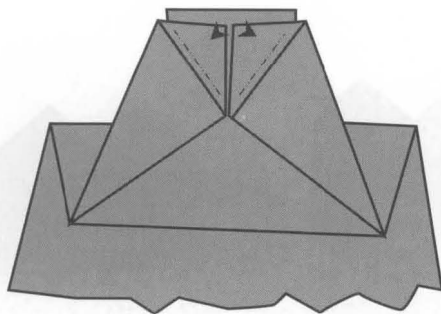

105

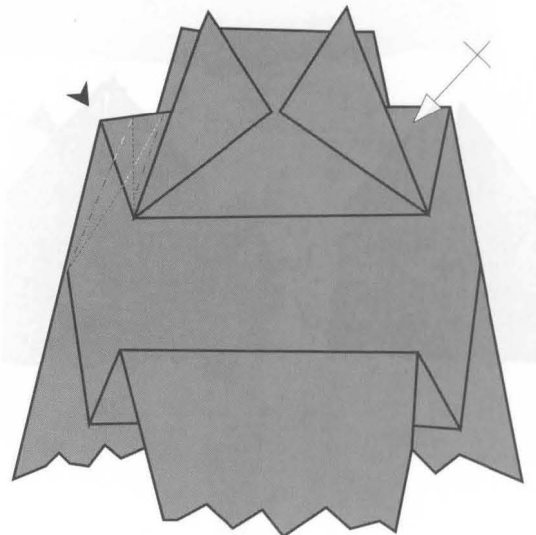

106

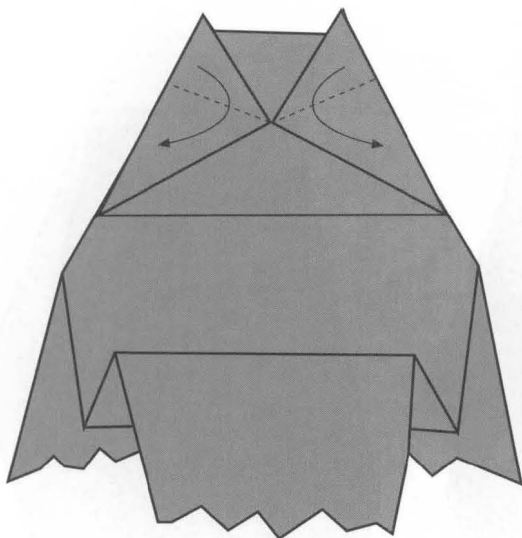

107

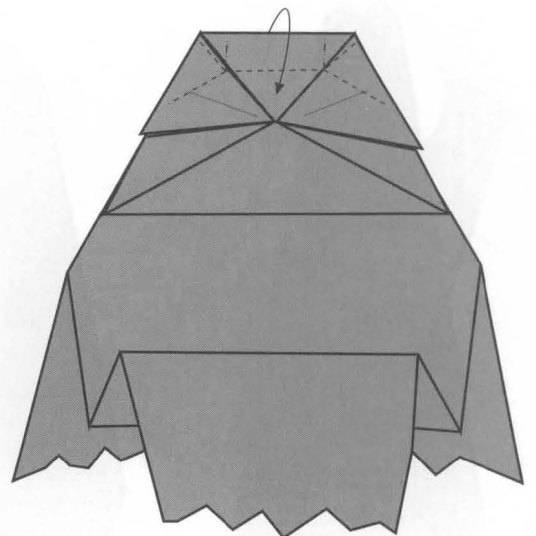

108

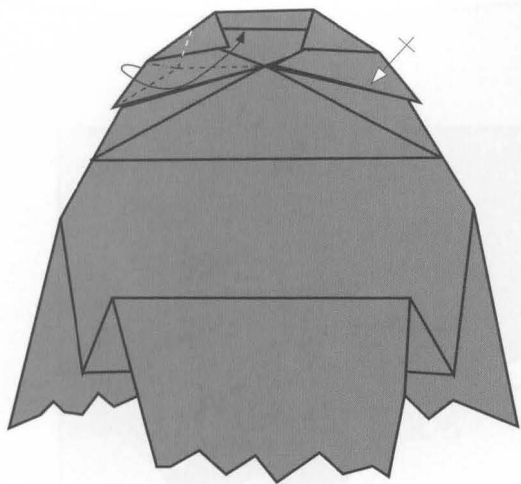

109

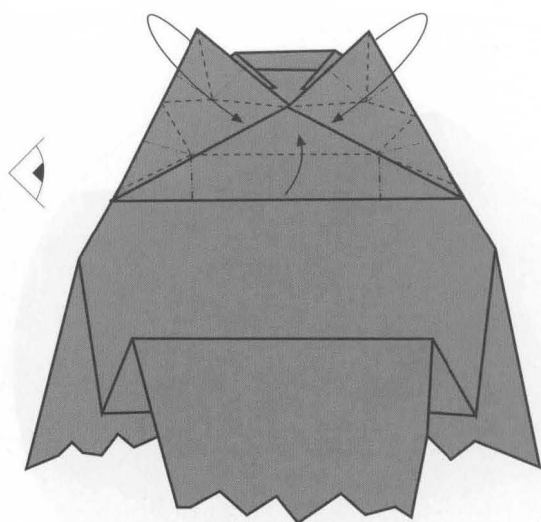

110

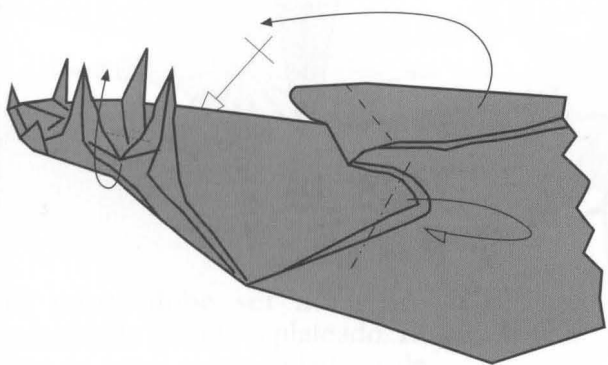

111

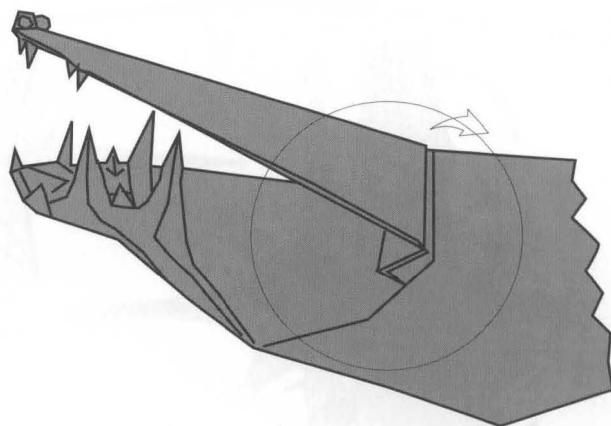

112

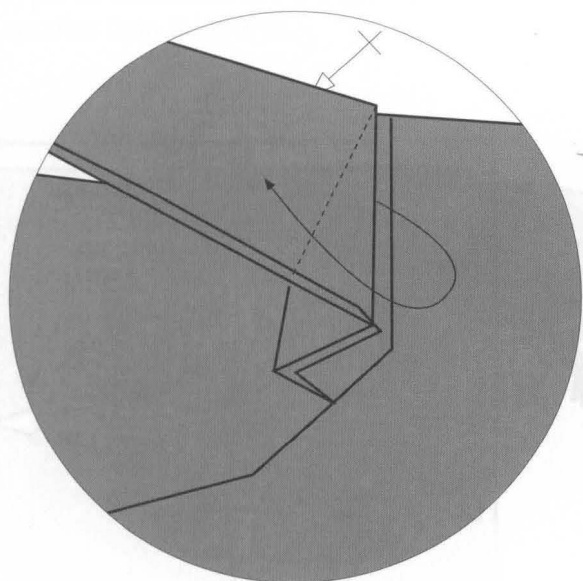

113

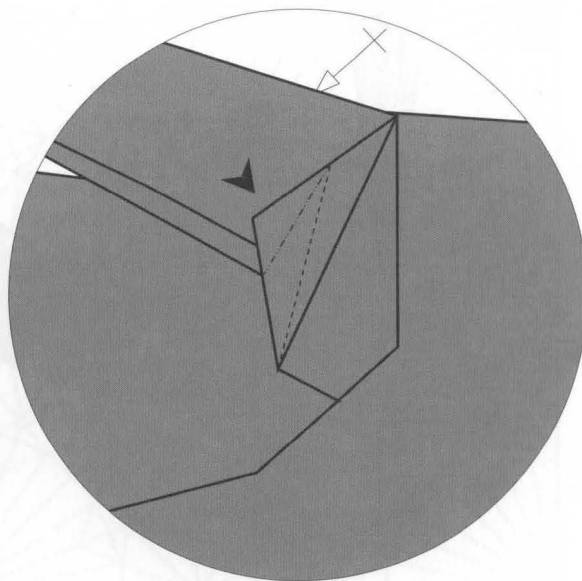

114

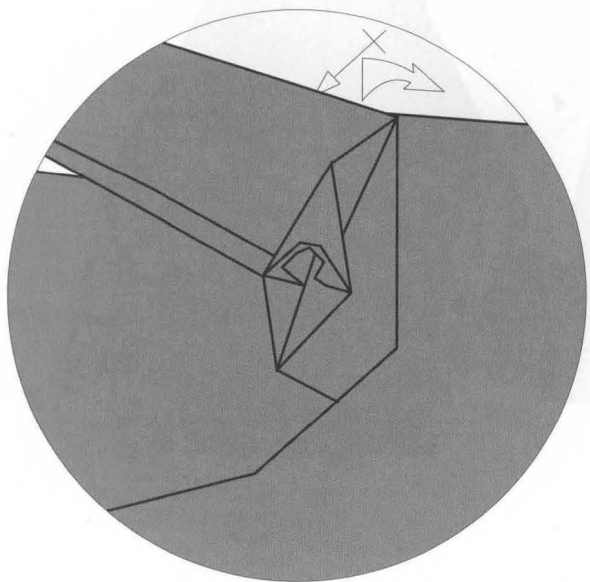

115

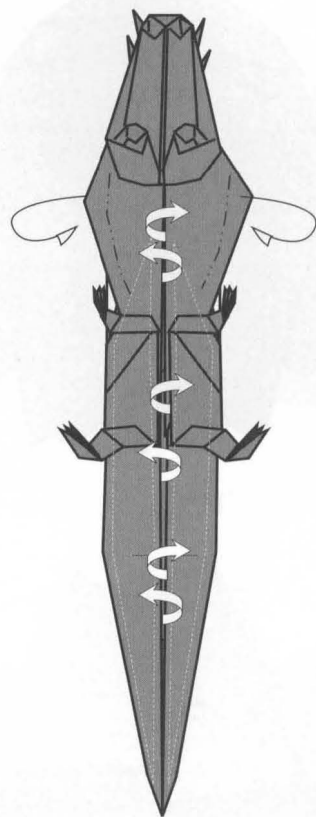

116

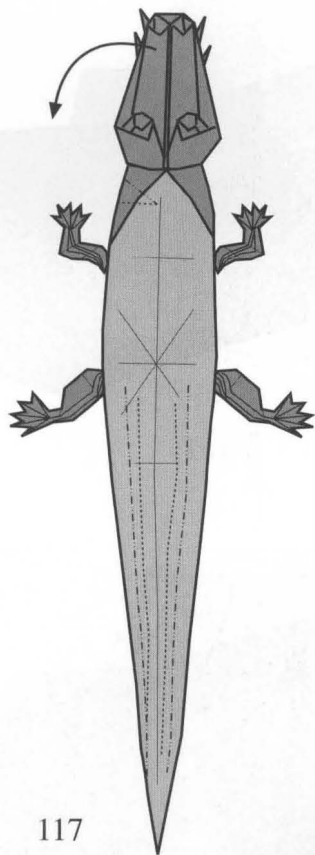

117

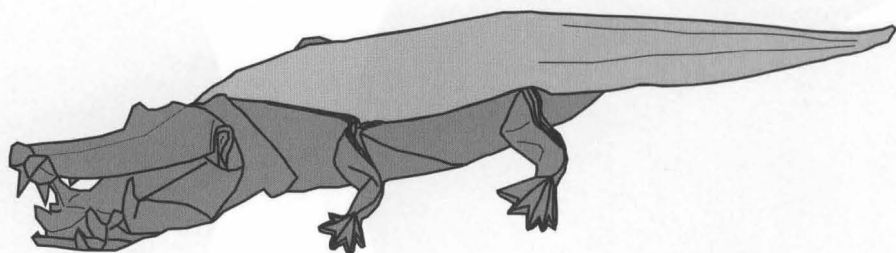

118

Estrella brillante

Shining star

© M. Sirgo - 2006

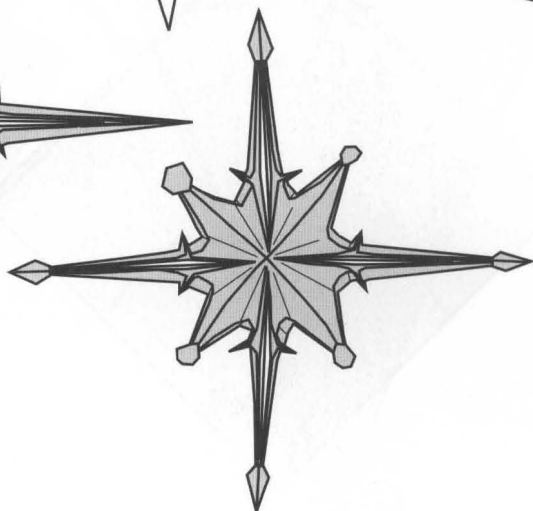
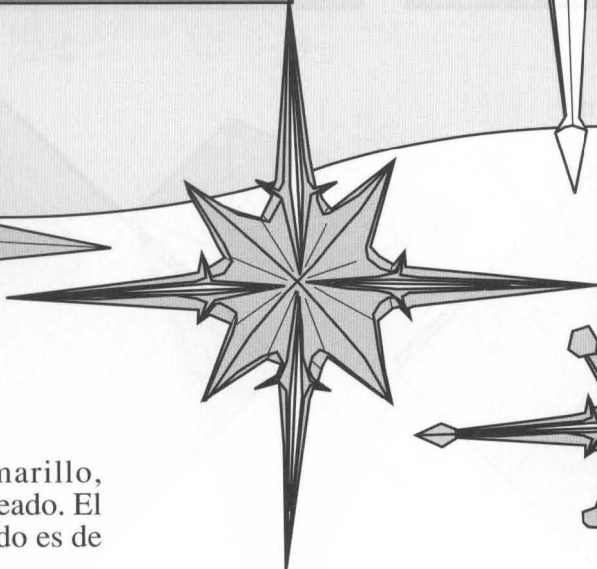
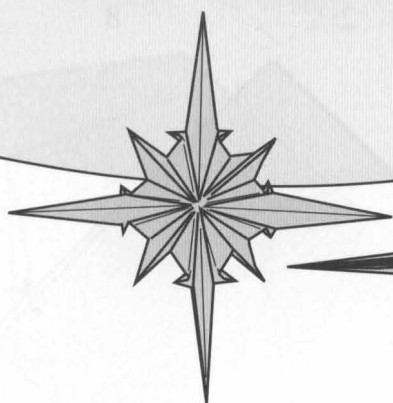
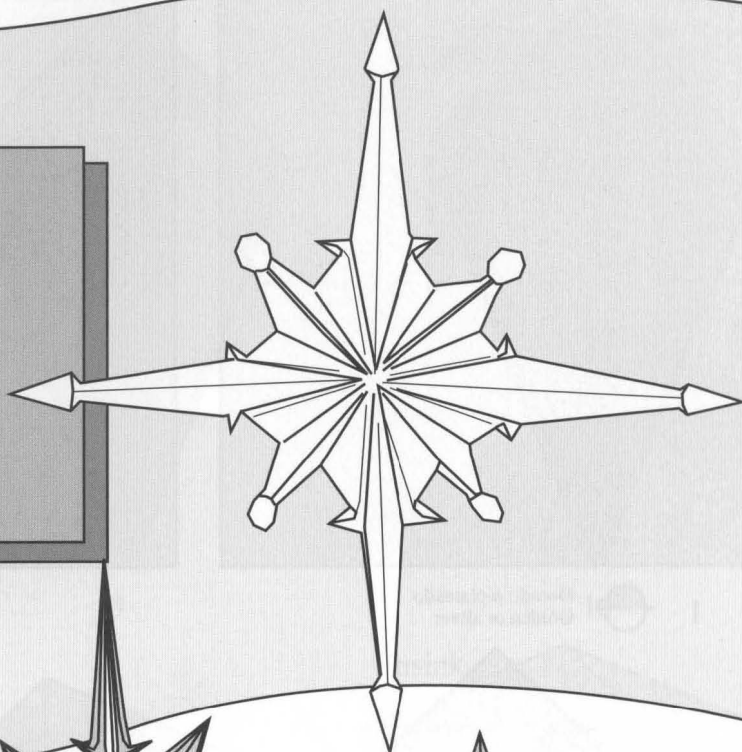

El papel debe ser amarillo, metalizado dorado o plateado. El tipo de papel recomendado es de menos de 80 gramos.

The paper should be yellow, metalized golden or silver. The type of recommended paper is smaller than 80 grams.

0,8

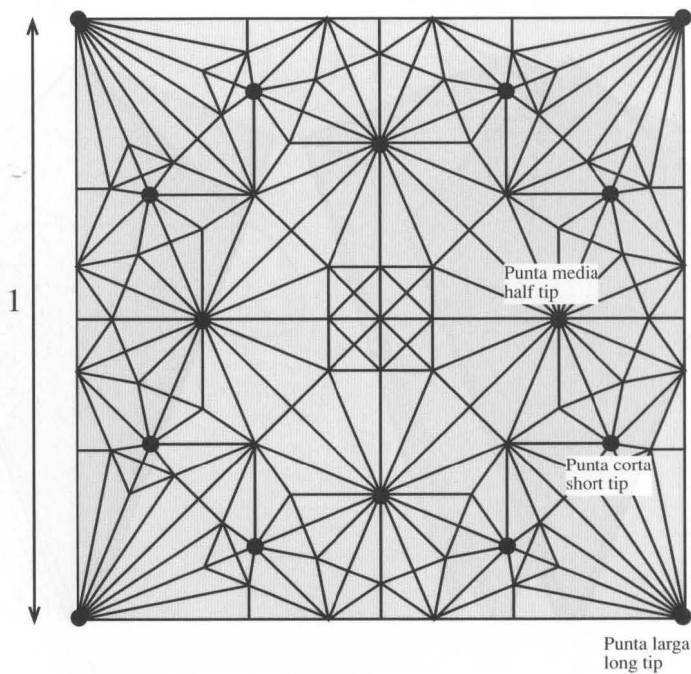
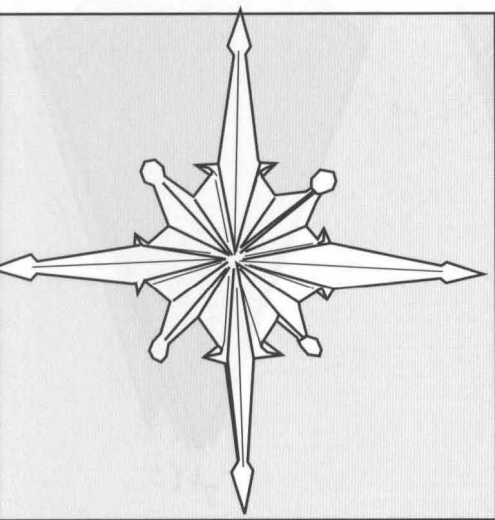

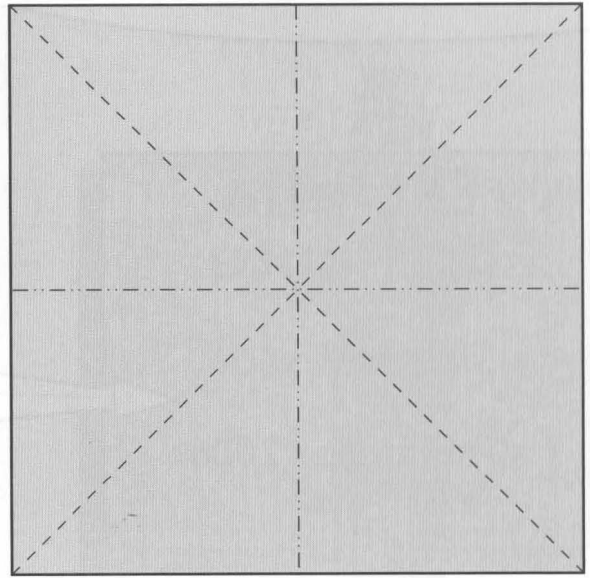
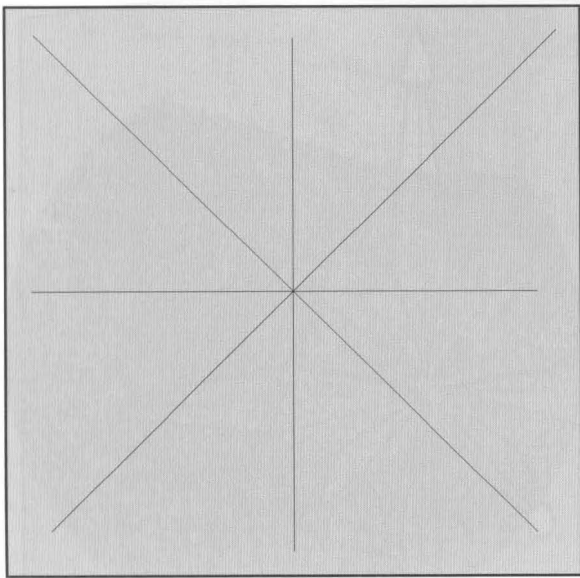

1  Dorado o plateado
Golden or silver

2

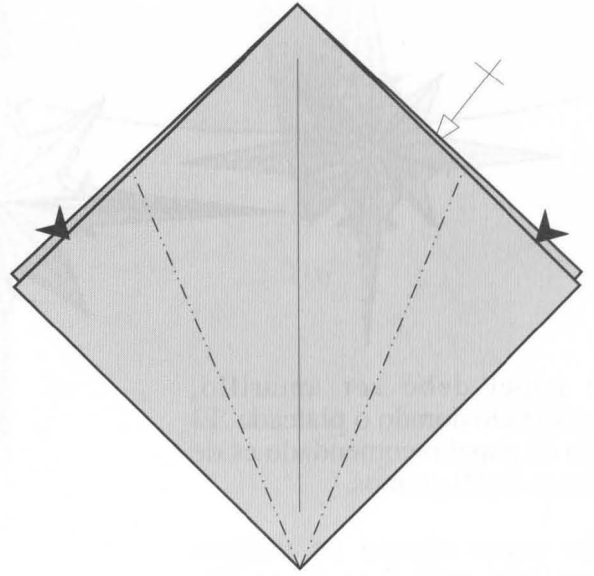
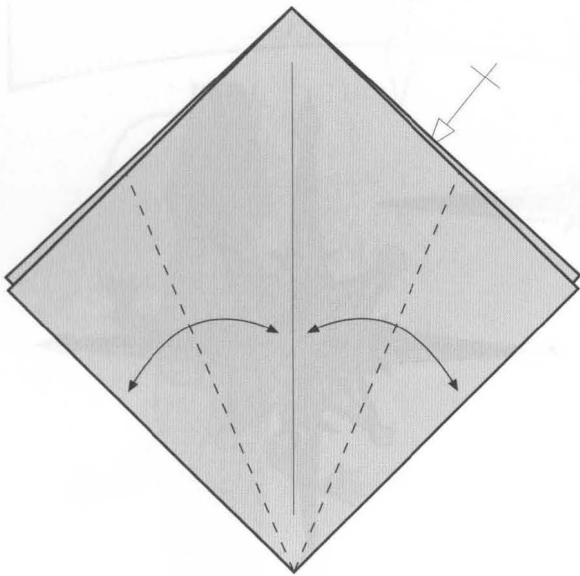

3

4

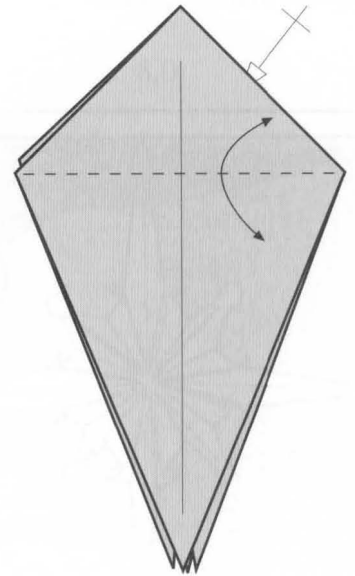
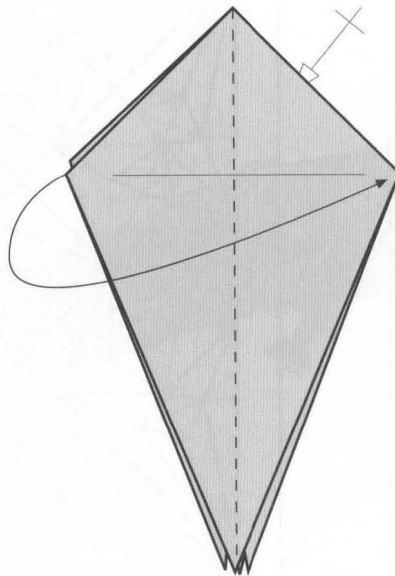
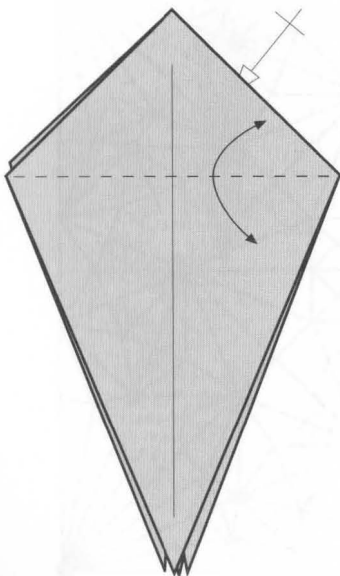

5

6

7

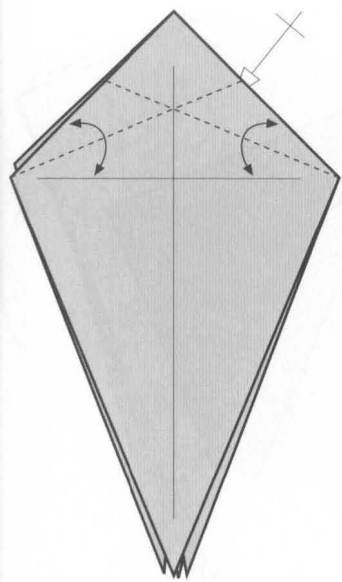

8

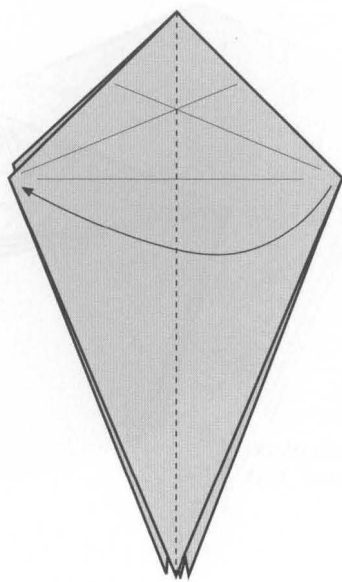

9

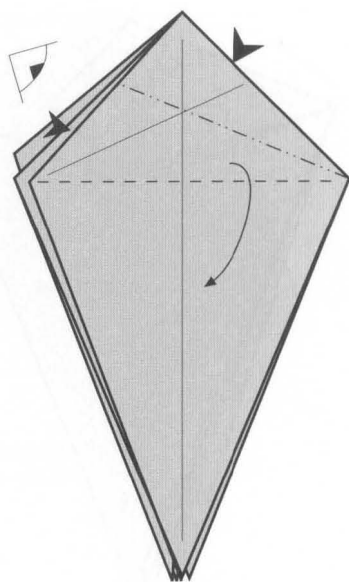

10

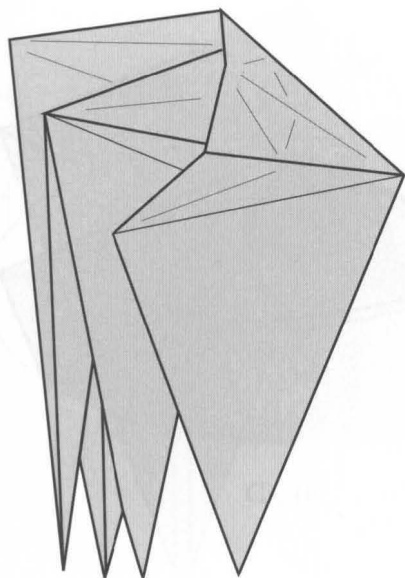

11 3D

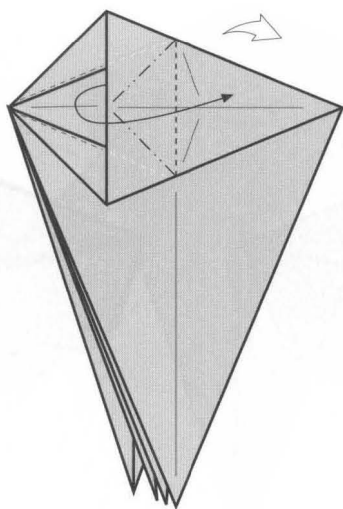

12

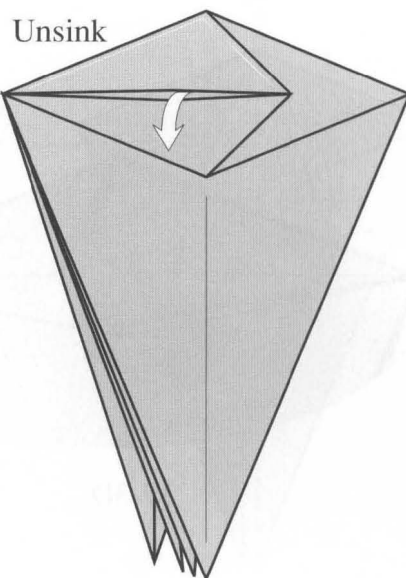

13

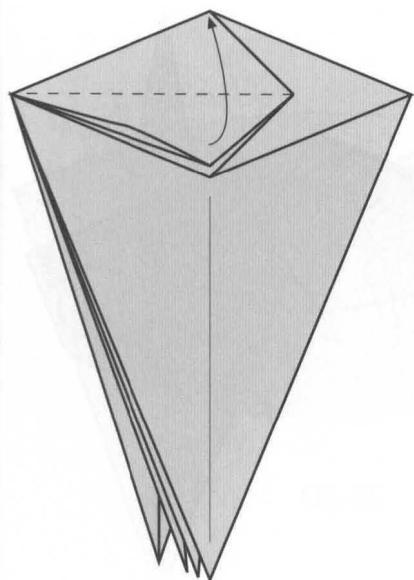

14

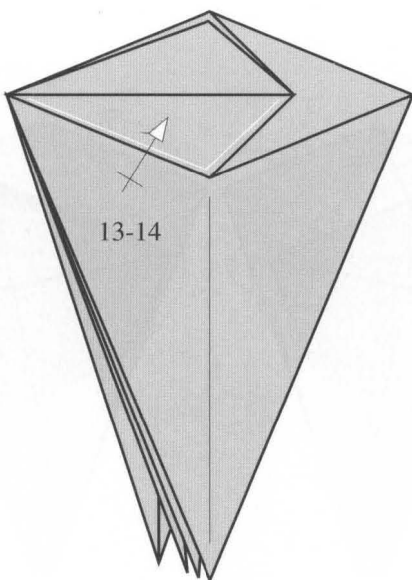

15

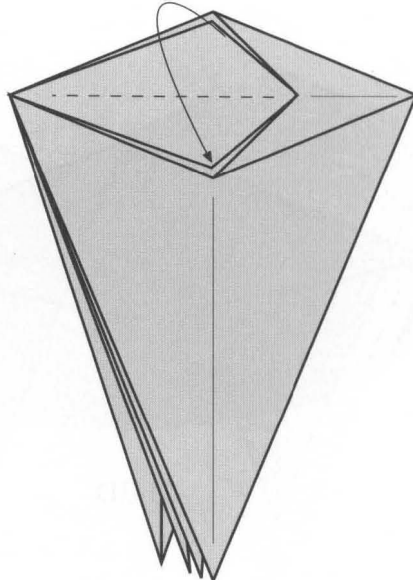

16

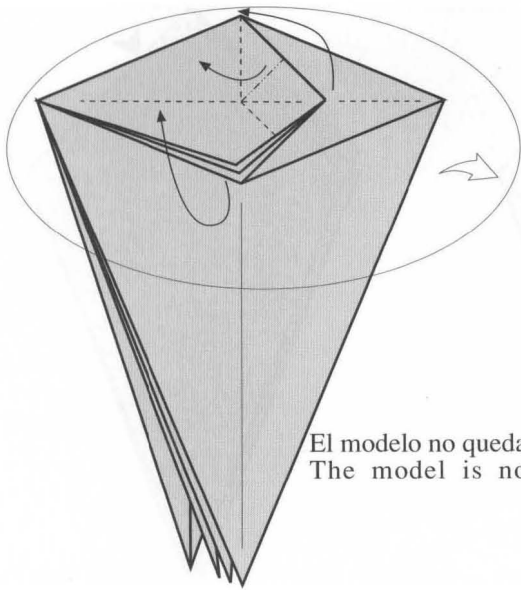

El modelo no queda plano
The model is not flat

17

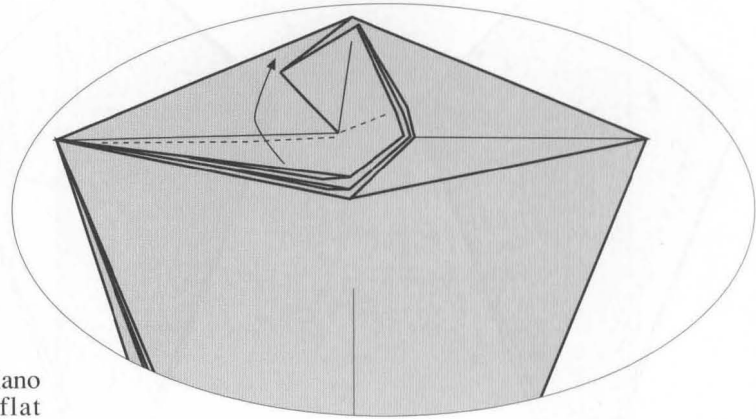

18-3D

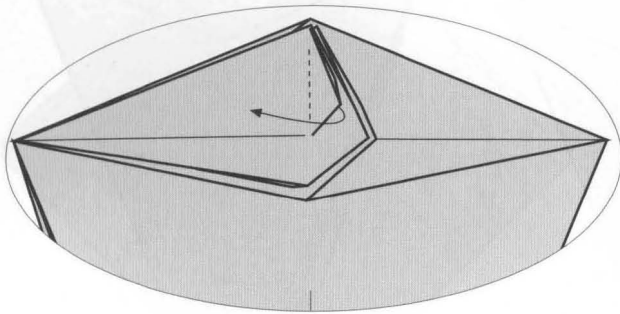

19-3D

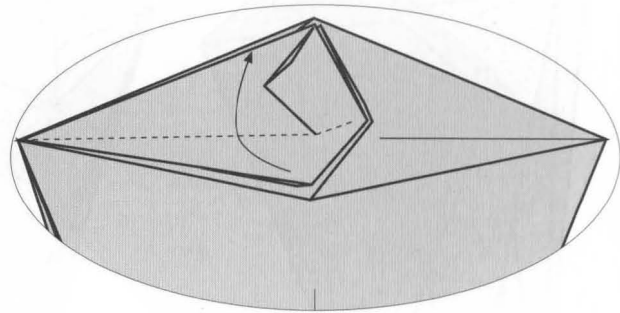

20-3D

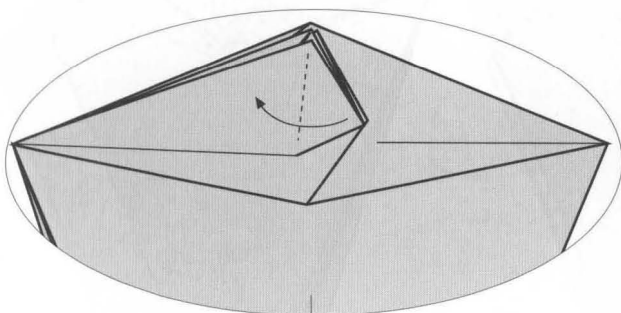

21-3D

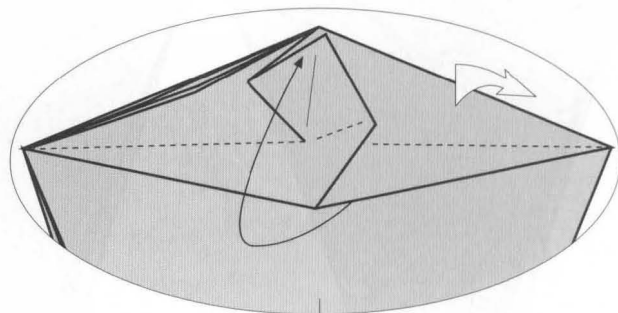

22-3D

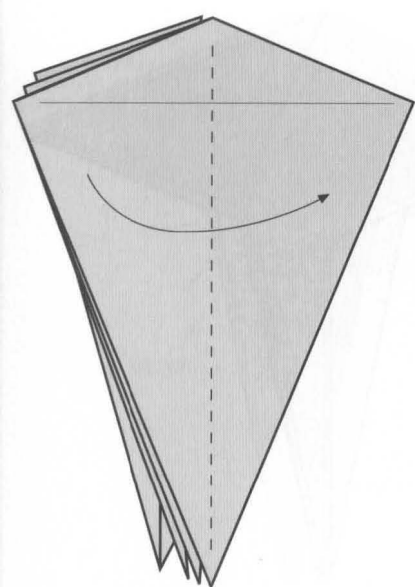

23

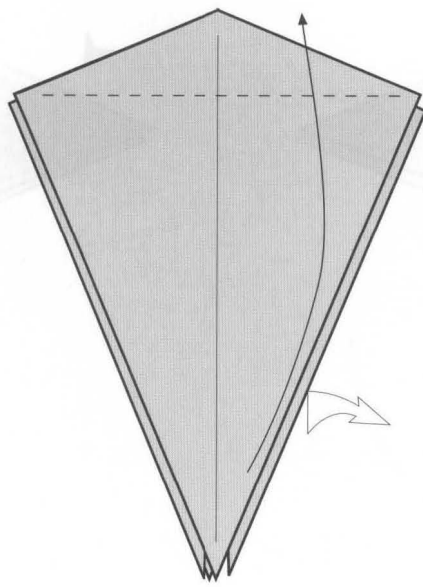

24

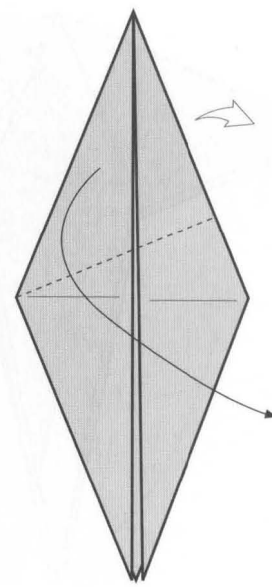

25

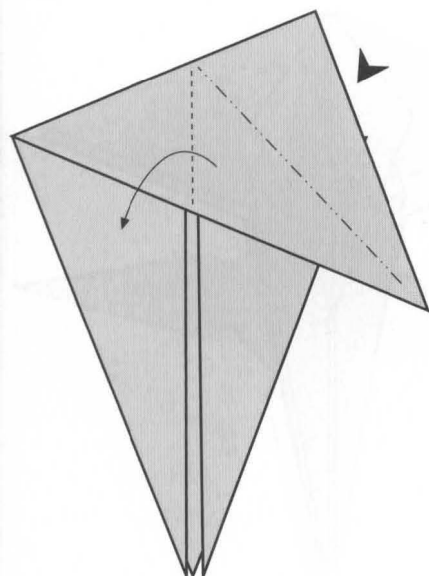

26

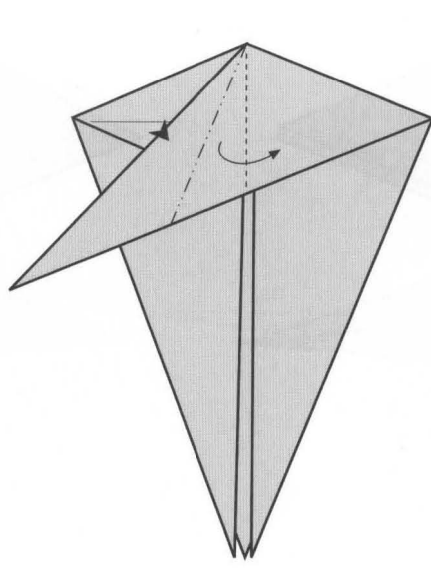

27

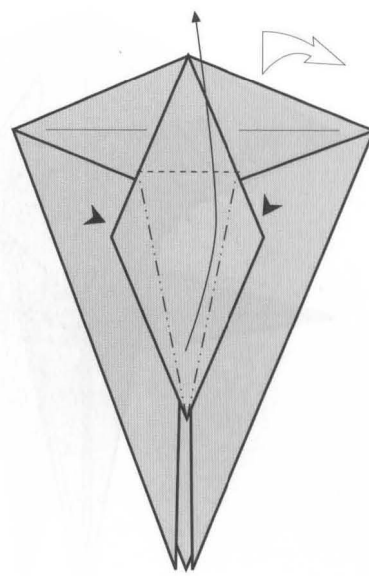

28

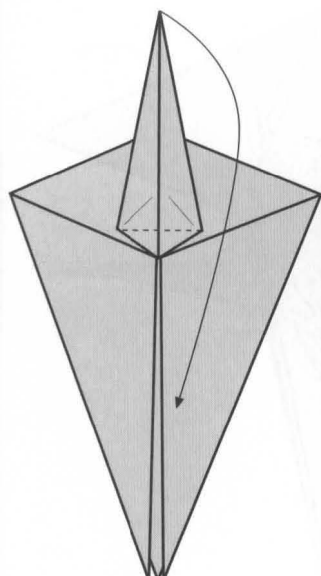

29

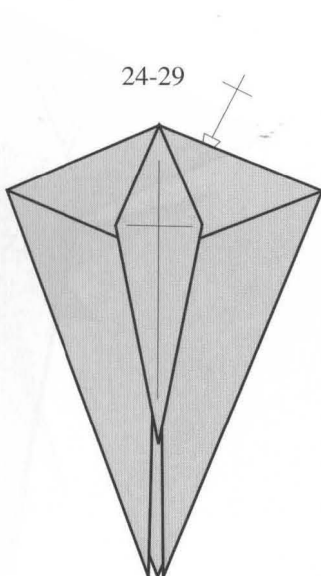

30

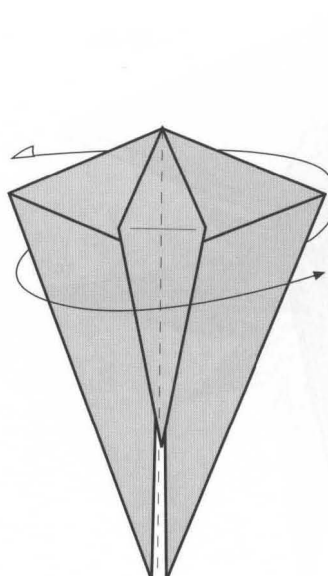

31

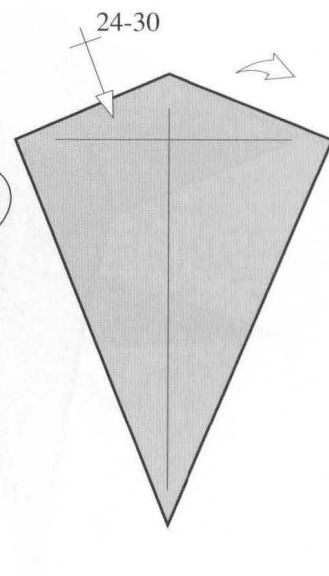

32

24-29

24-30

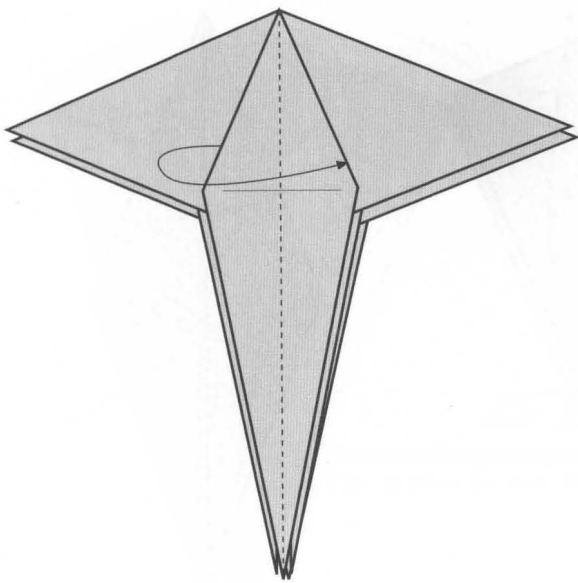

33

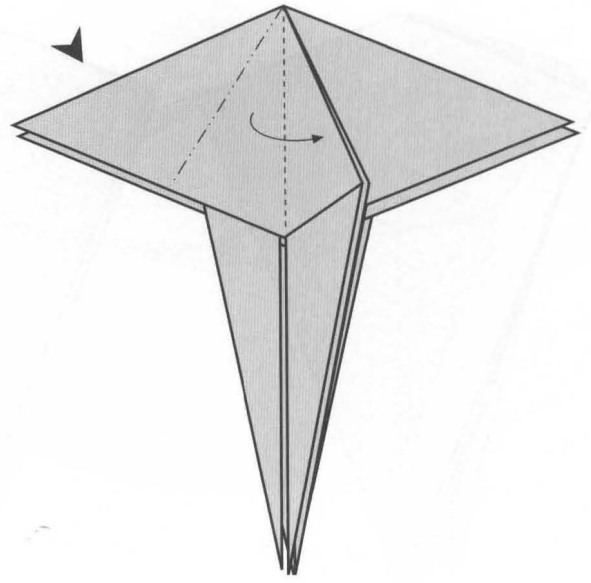

34

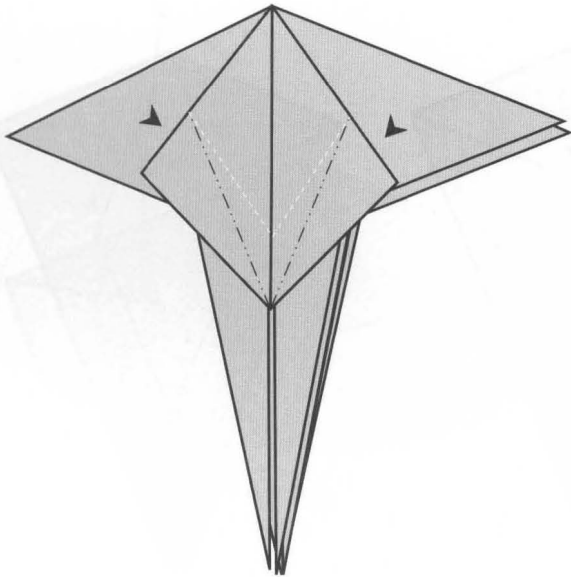

35

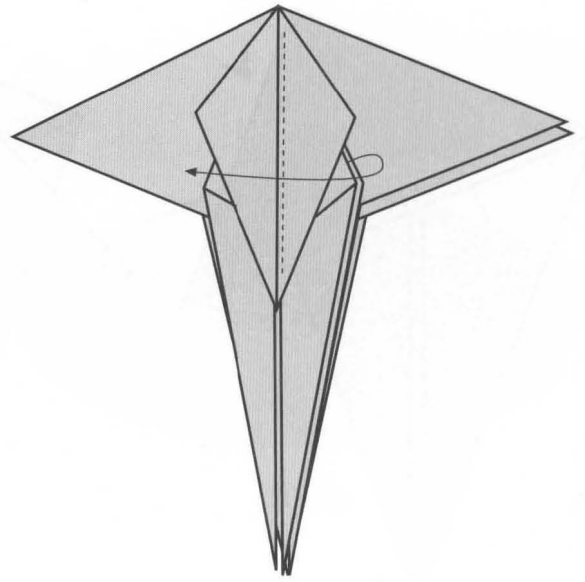

36

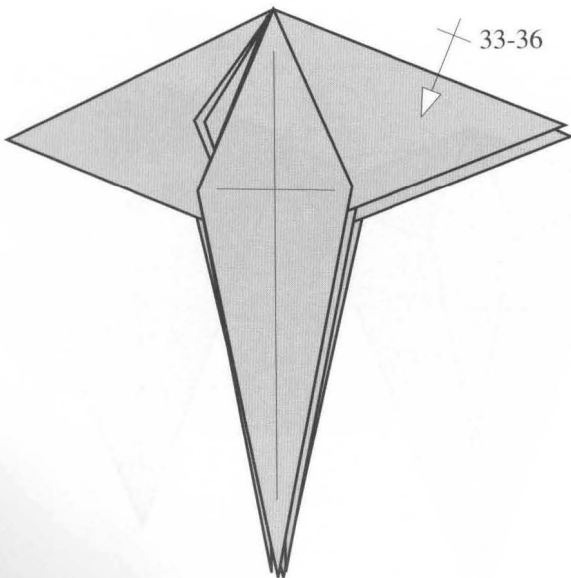

37

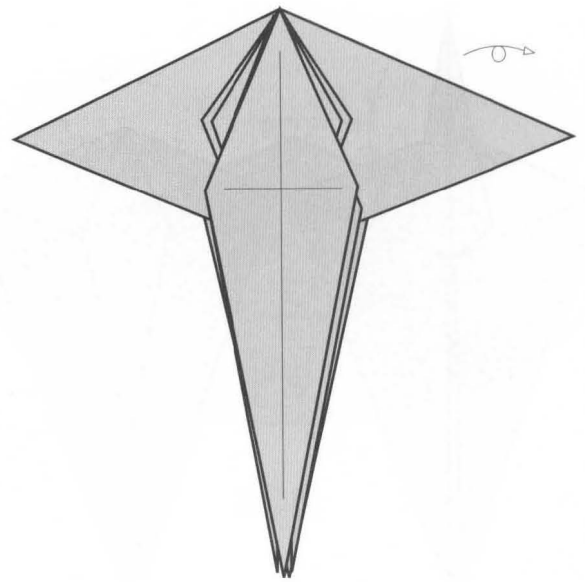

38

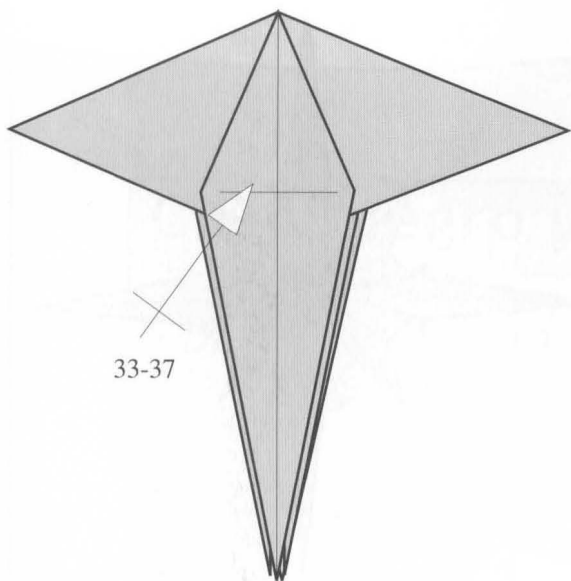

33-37

39

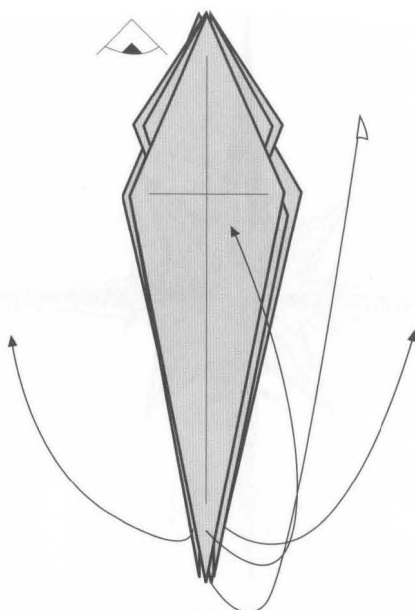

40

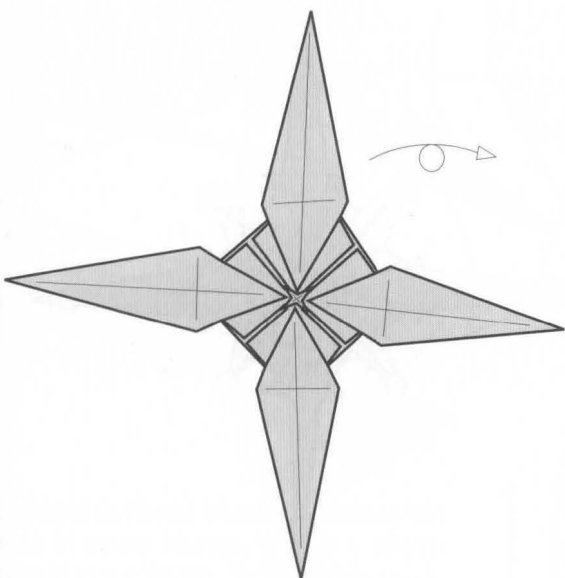

41

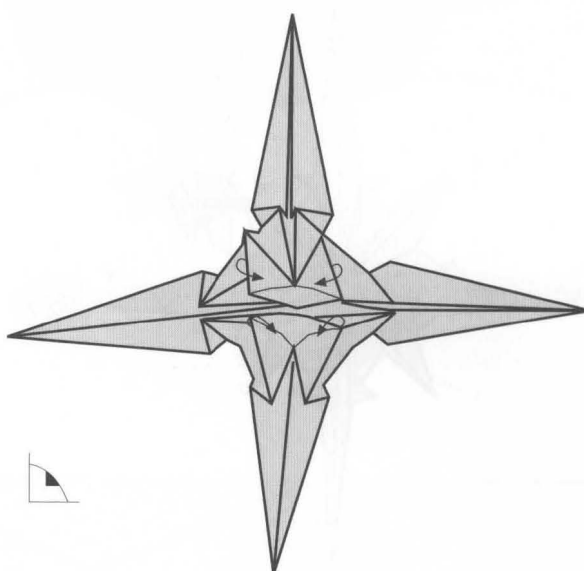

42



43-3D



44

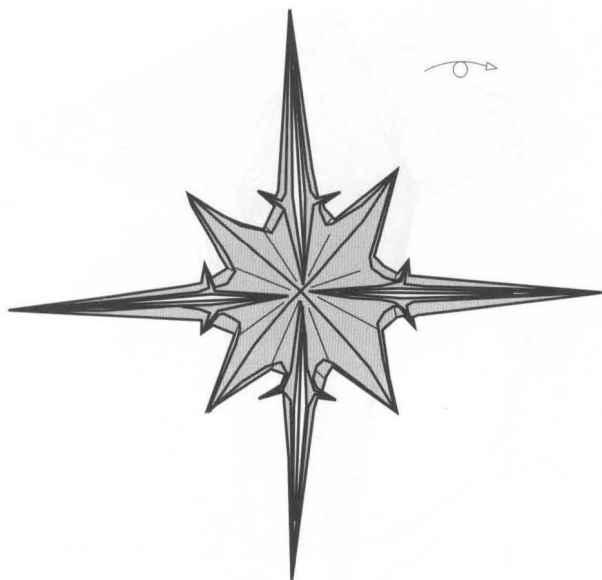

45

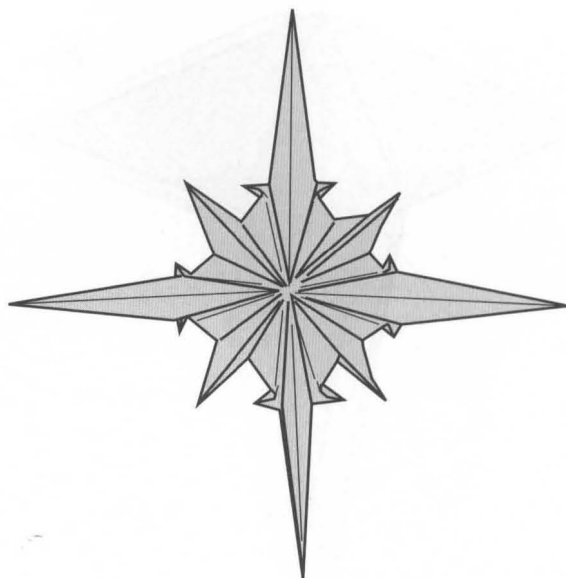

46

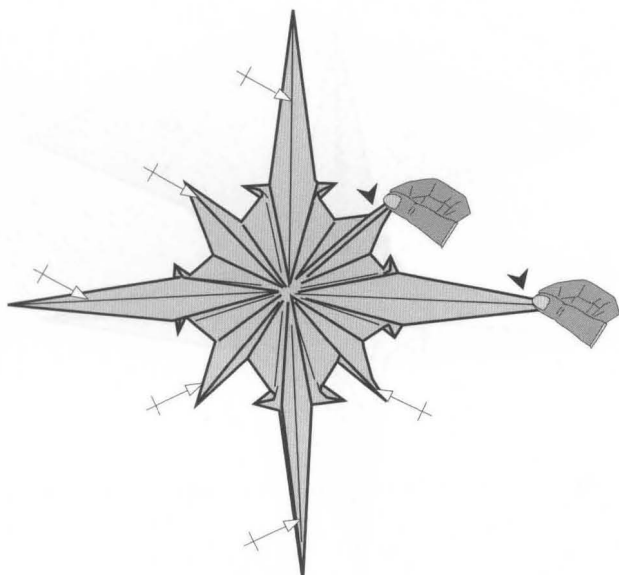

47

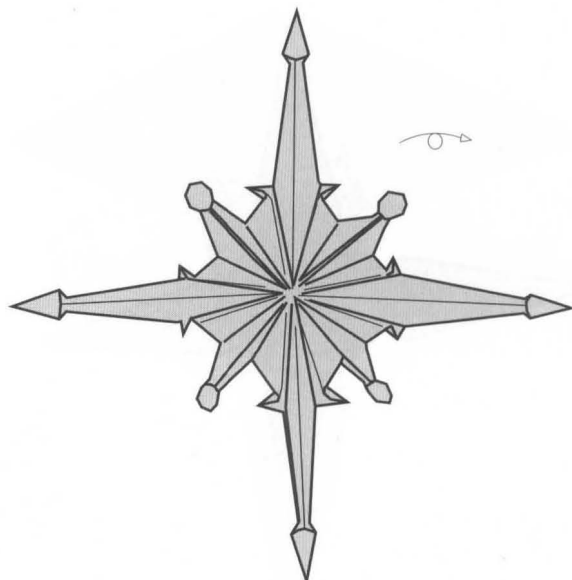

48

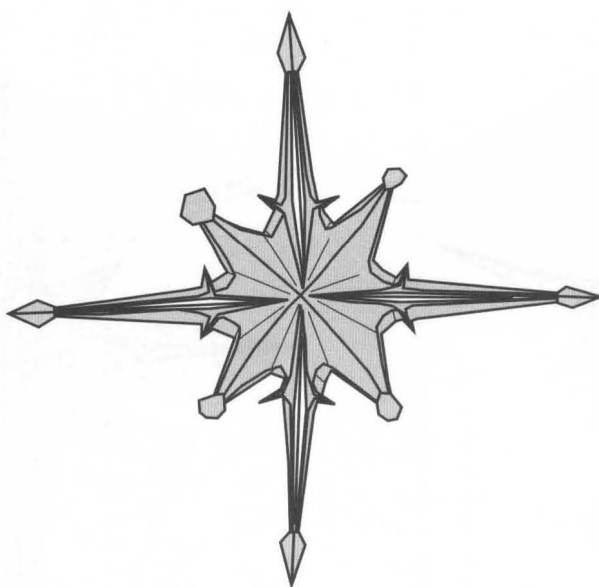

49

Cisne negro y blanco

Black swan and white swan

© M. Sirgo - 2005-6

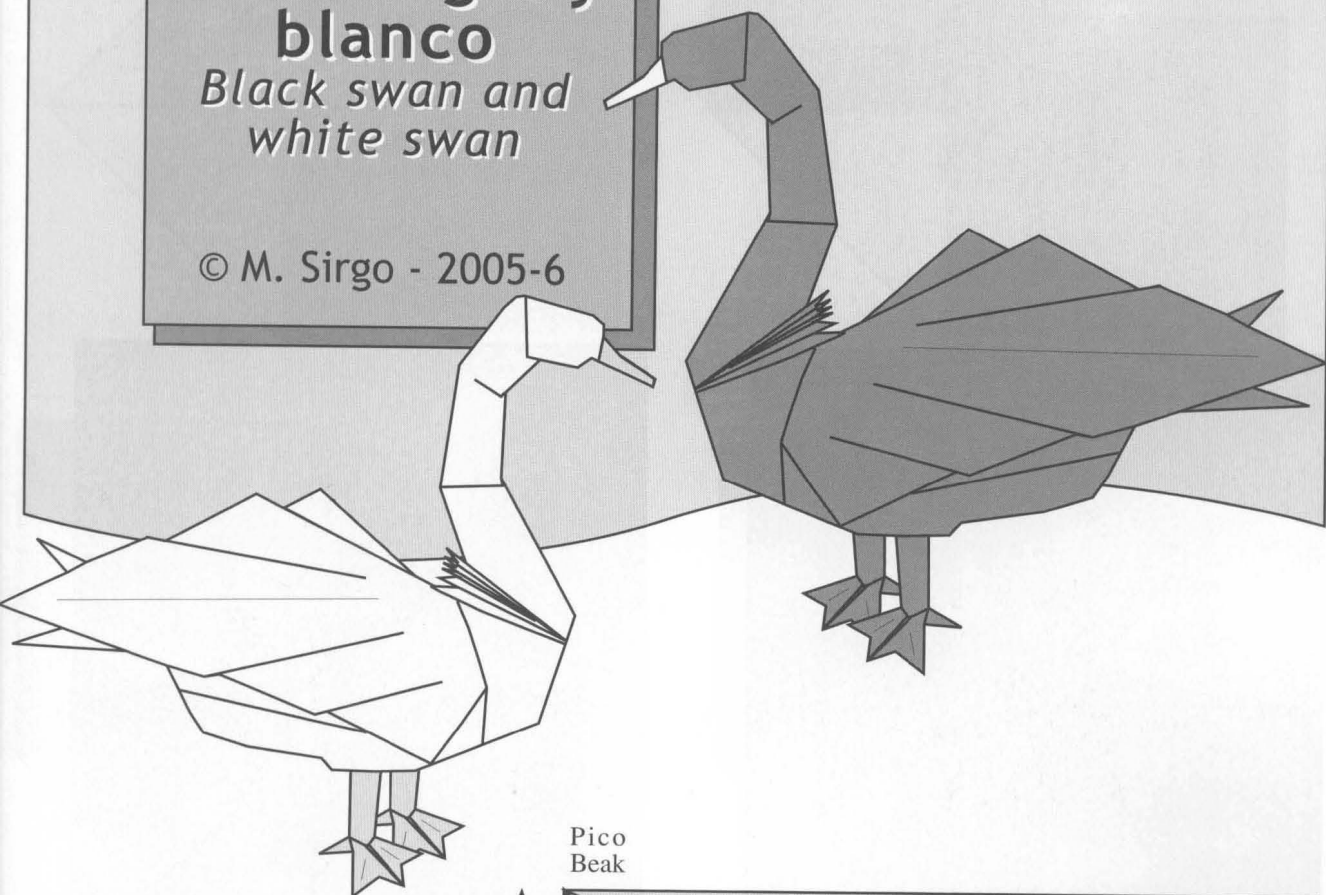

El papel debe ser blanco y anaranjado para el cisne blanco, y rojo y negro para el cisne negro. Se recomienda de menos de 40 gramos, doble seda o del tipo *sandwich* y de dimensión 35x35 cm o mayor.

The paper should be white and orange for the white swan. Red and black for the black swan. It is recommended smaller than 40 grams, double silk or of the type "sandwich" and of dimension 35x35 cm or bigger.

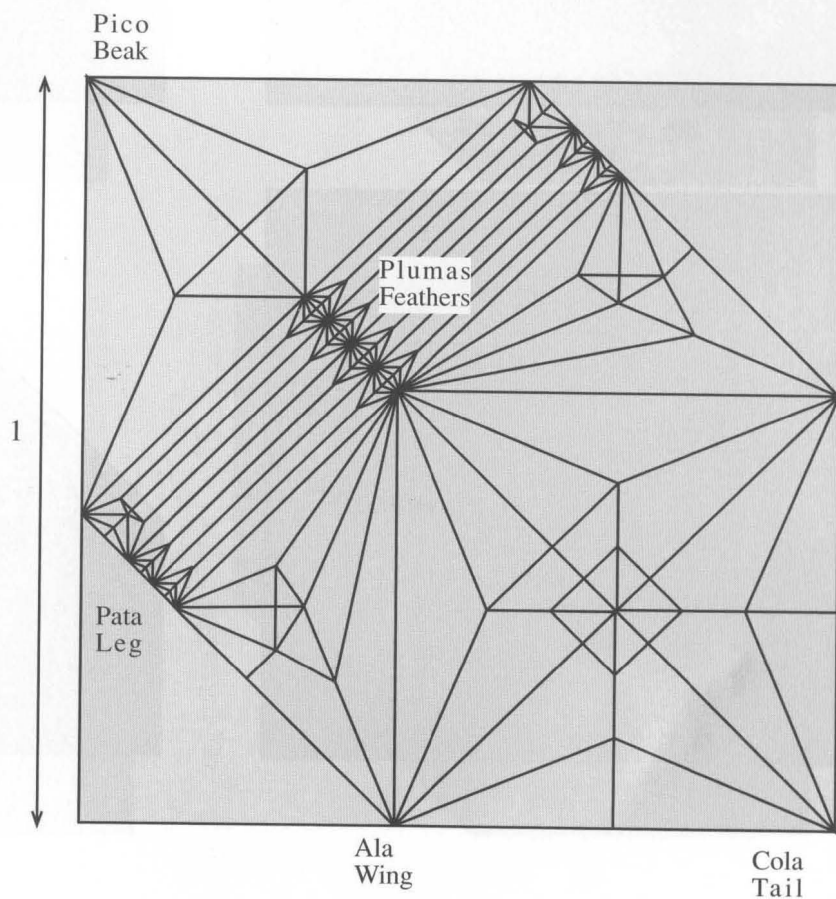
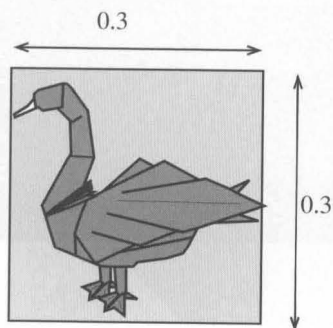

Cisne negro Black swan

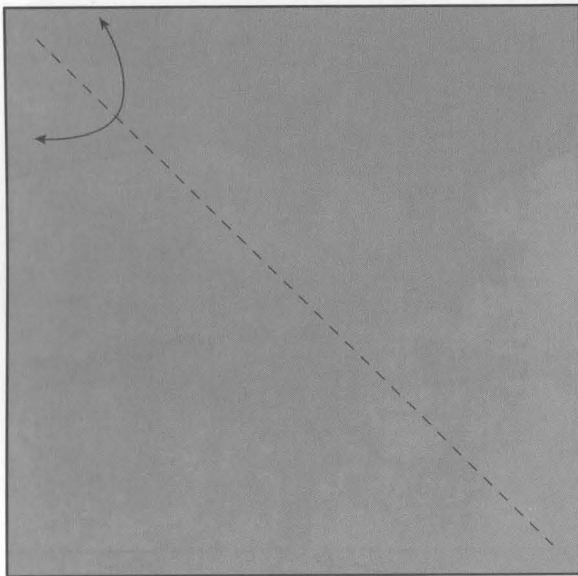

1  Negro, black
Rojo, red

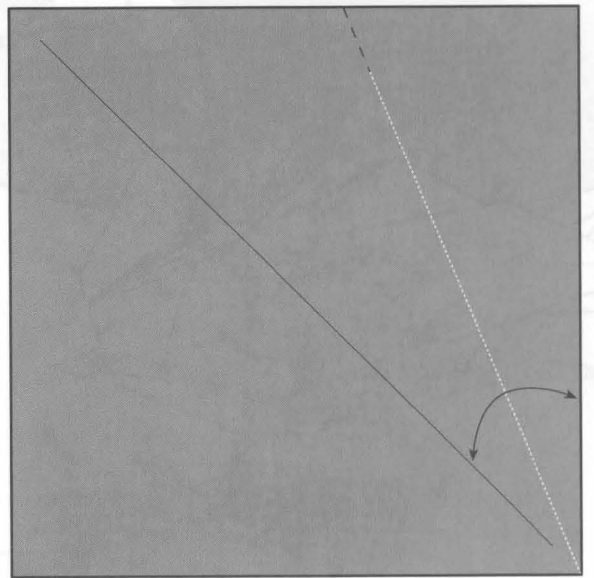

2

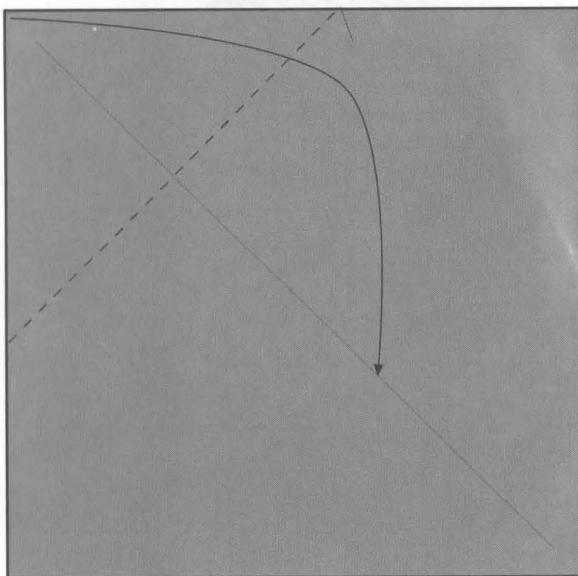

3

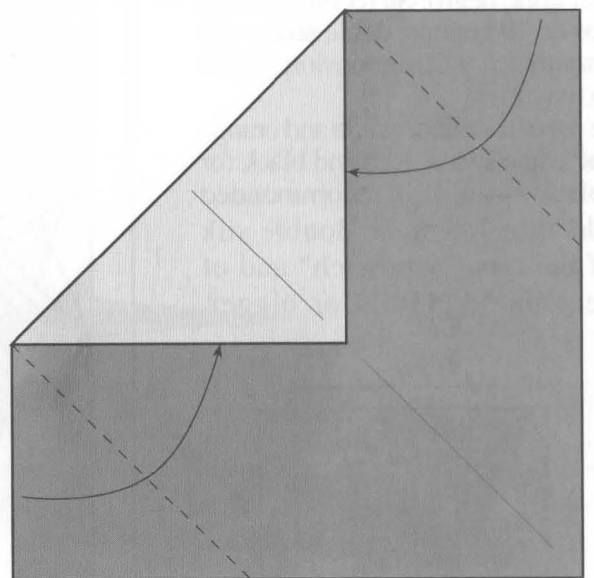

4

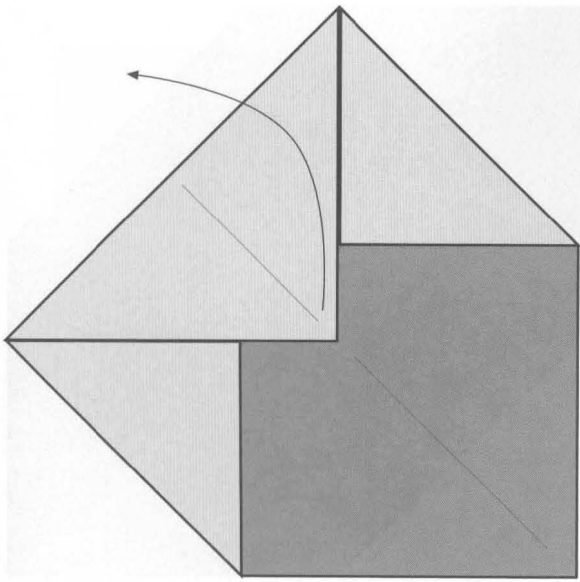

5

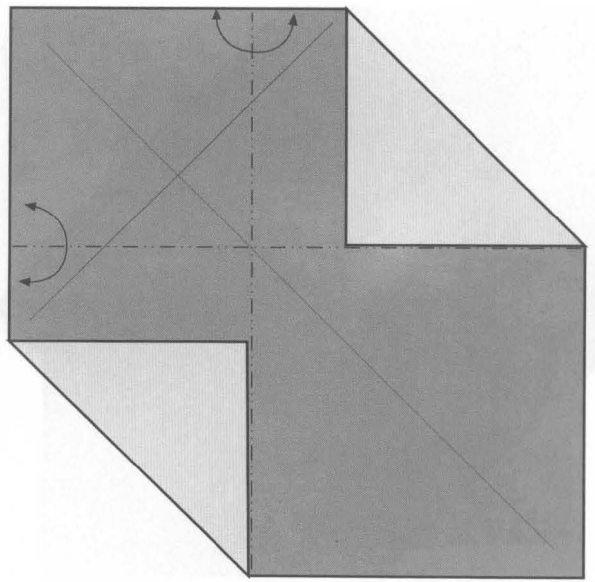

6

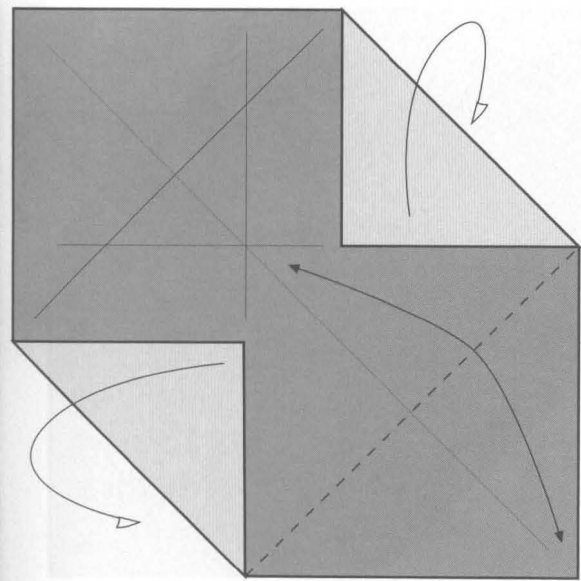

7

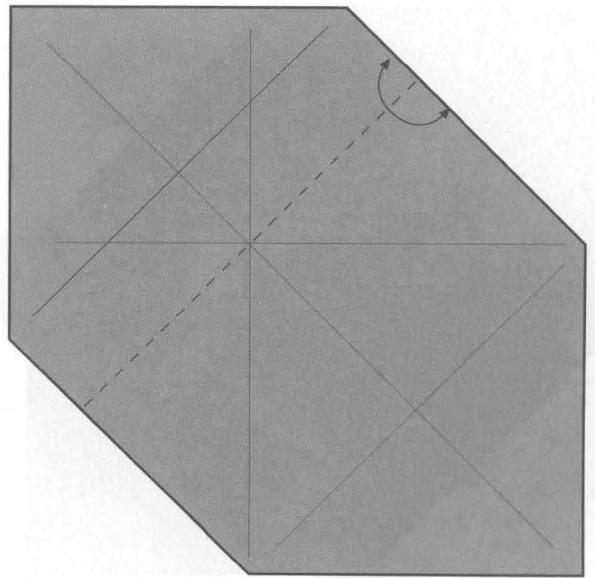

8

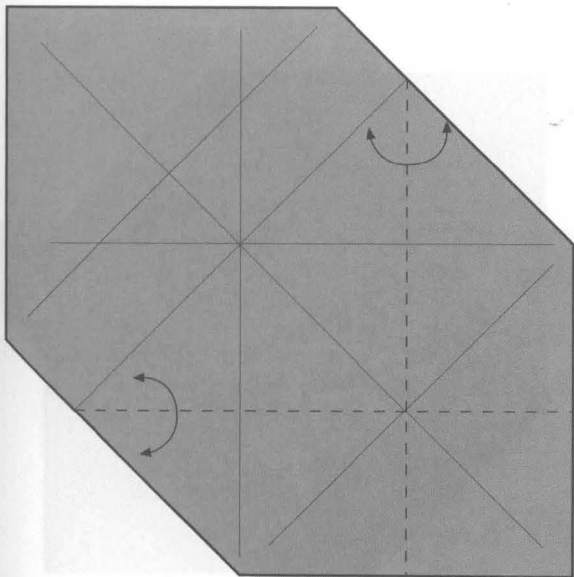

9

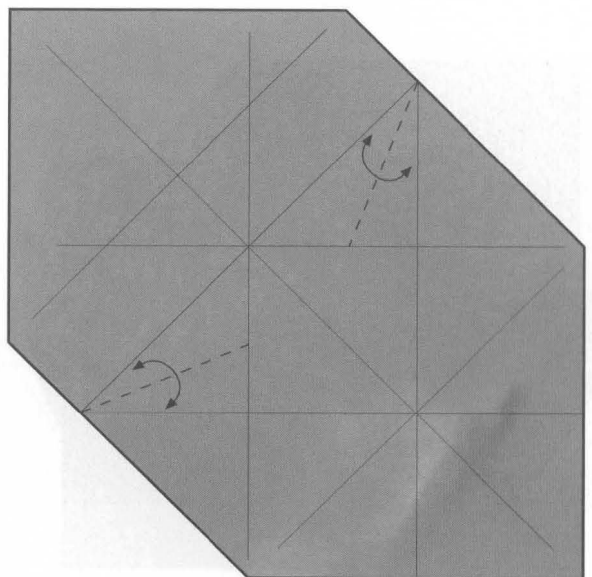

10

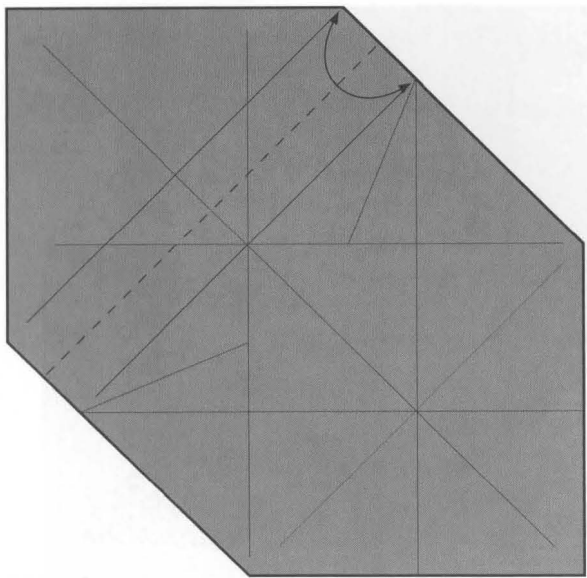

11

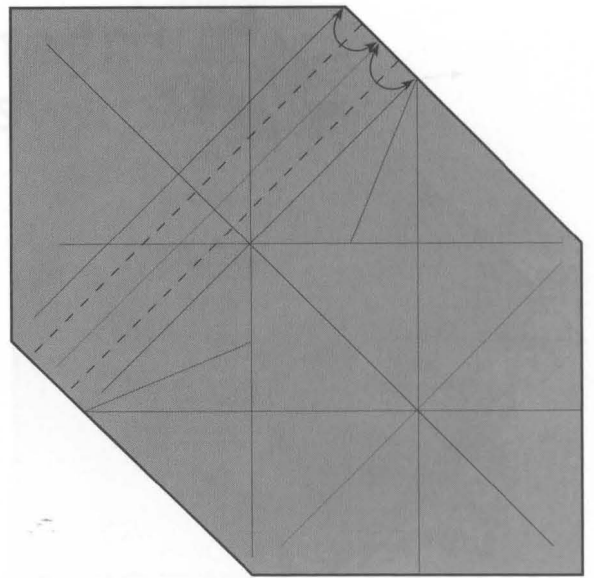

12

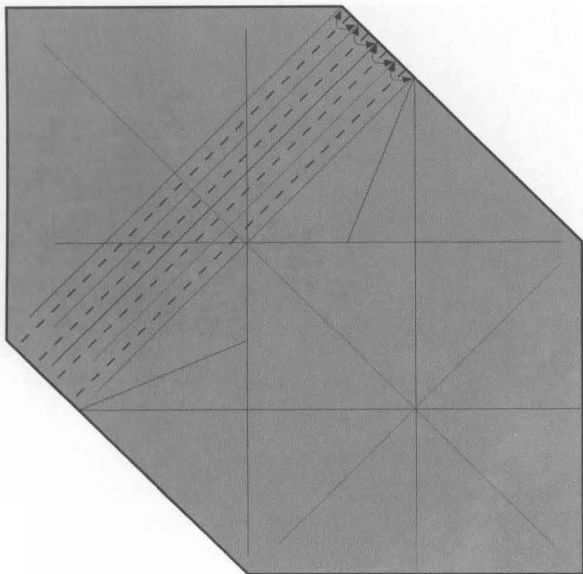

13

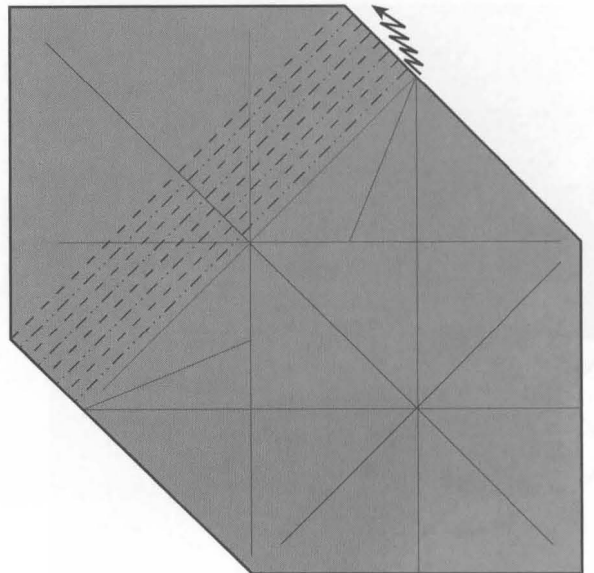

14

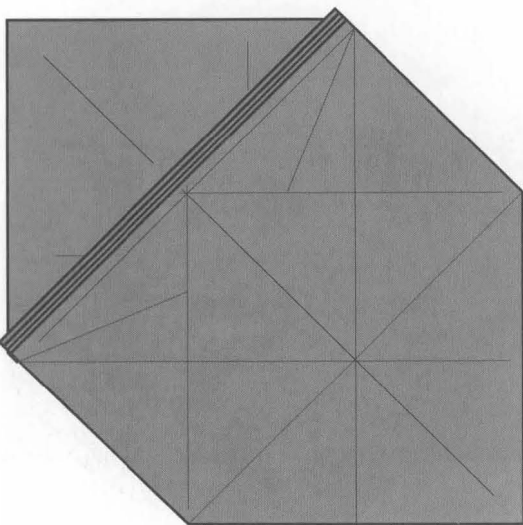

15 En proceso
In process

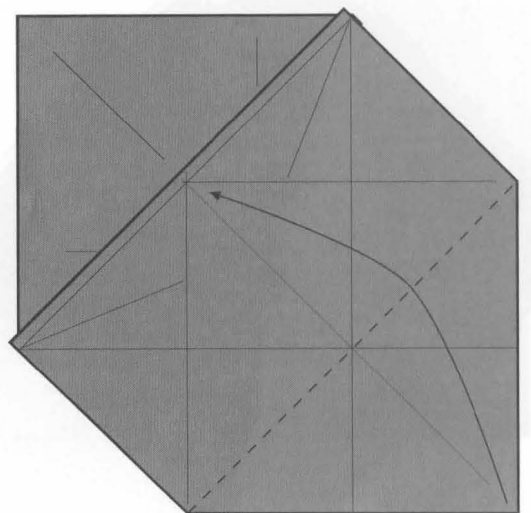

16

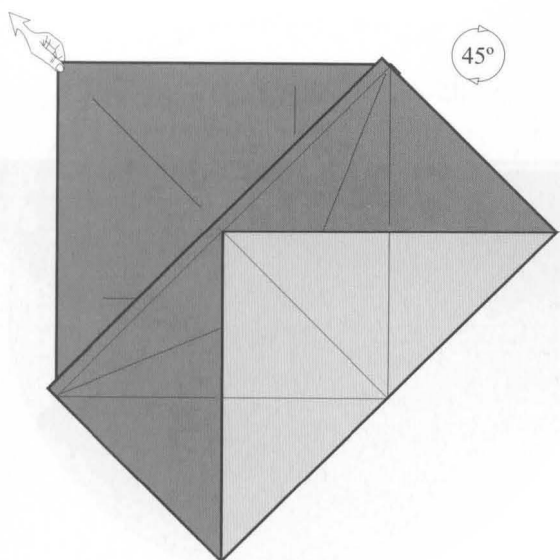

17

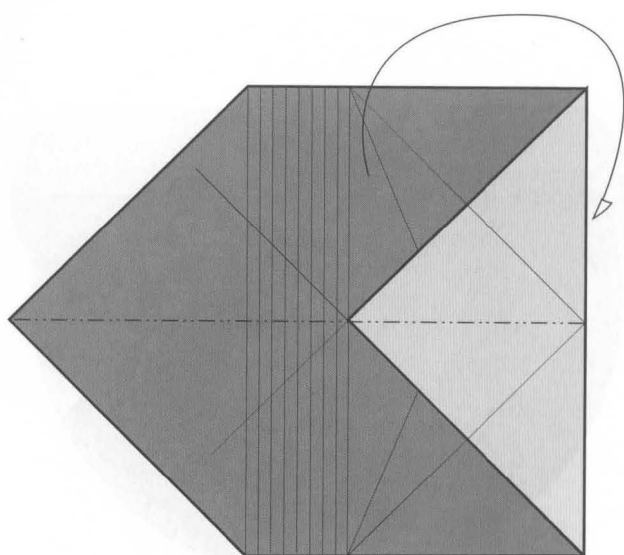

18

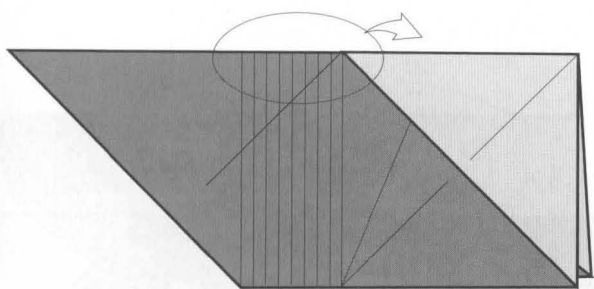

19

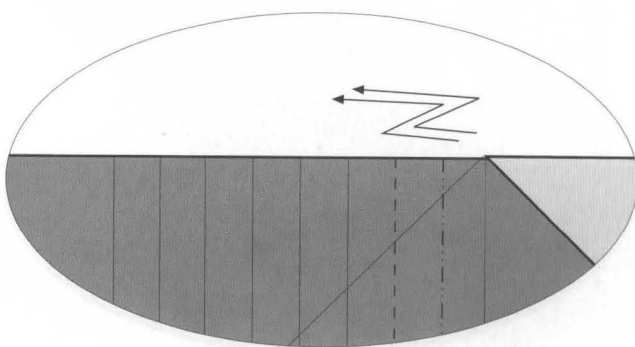

20

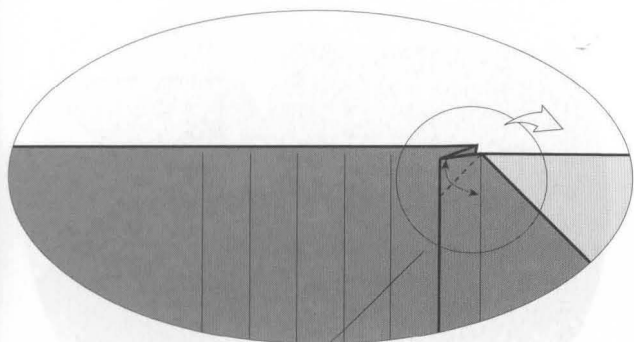

21

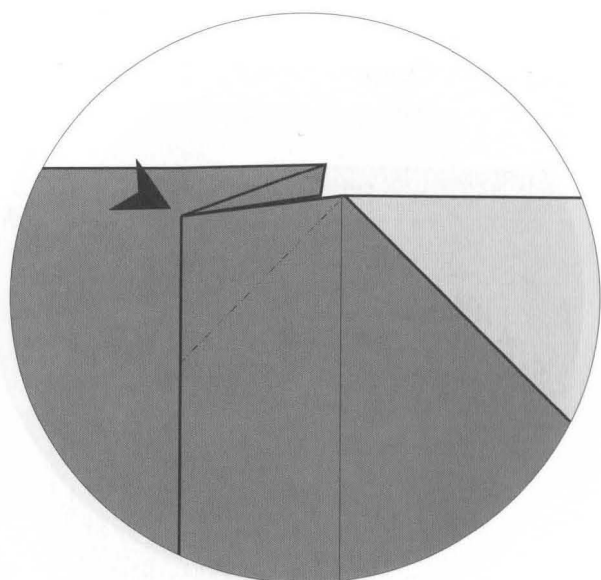

22

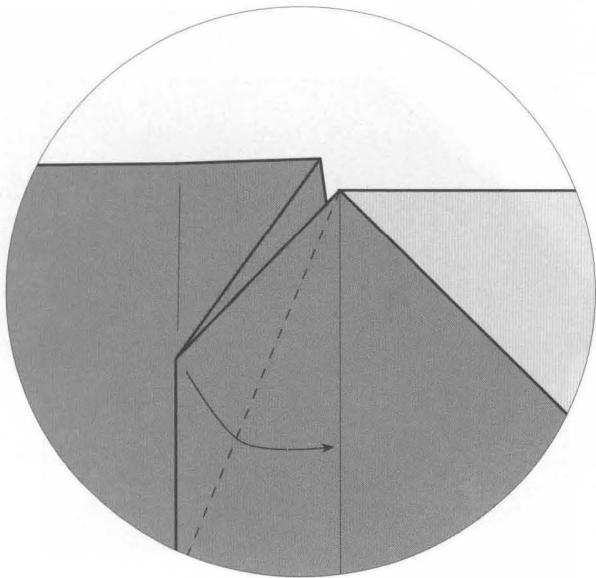

23

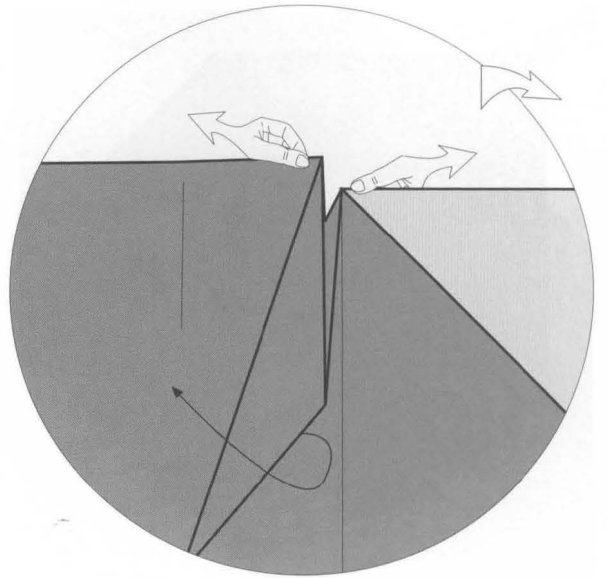

24

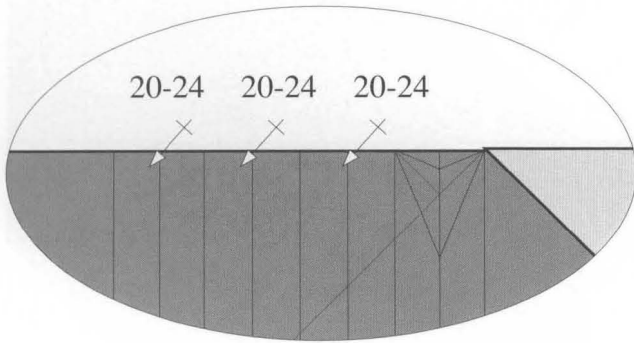

25

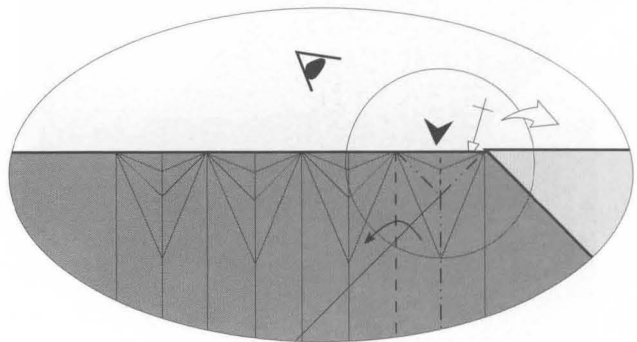

26

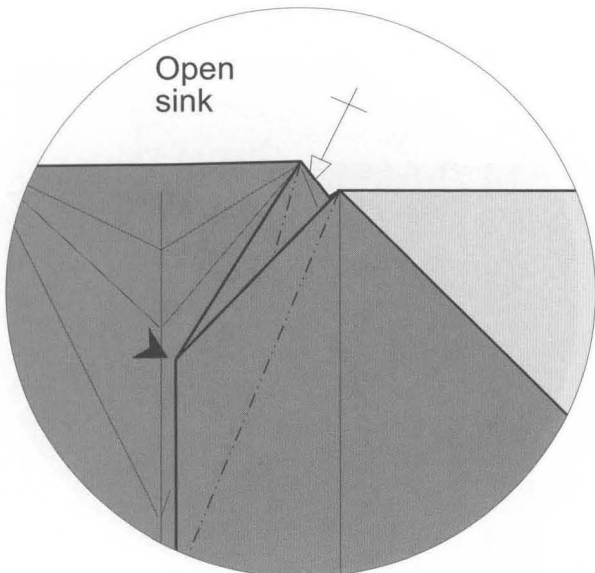

27

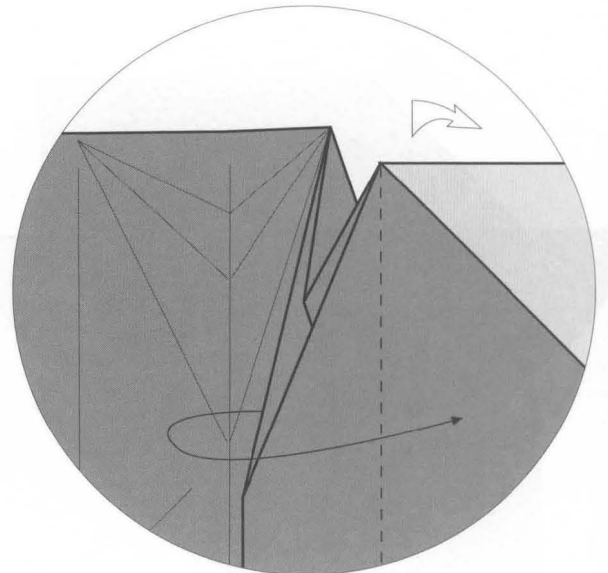

28

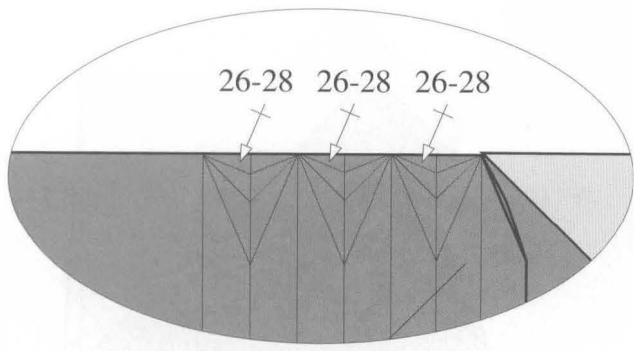

29

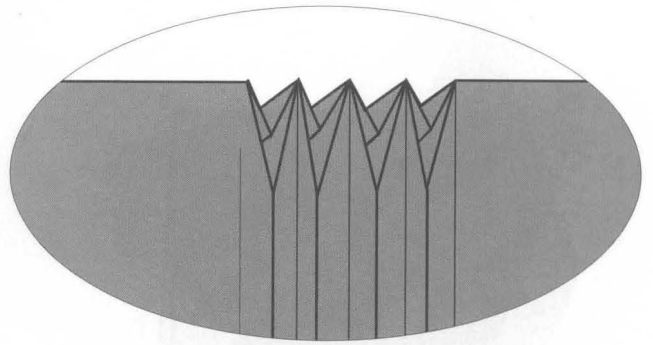

30

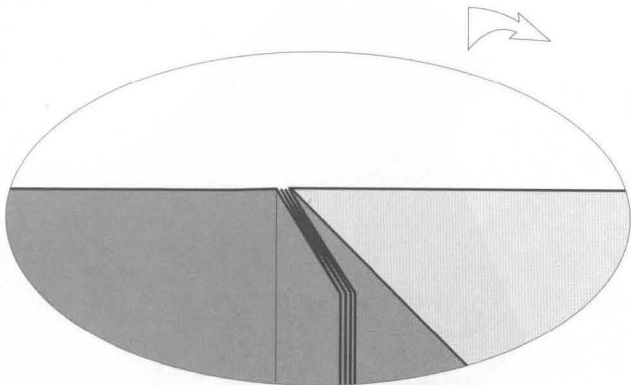

31

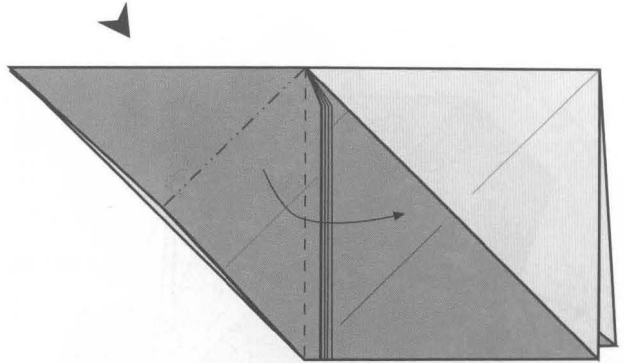

32

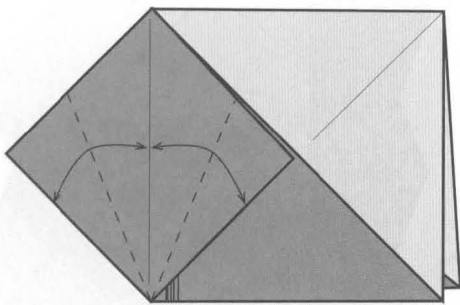

33

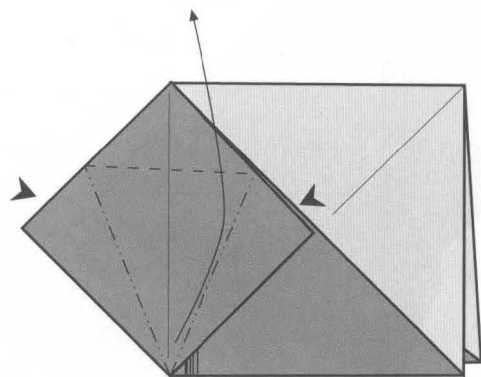

34

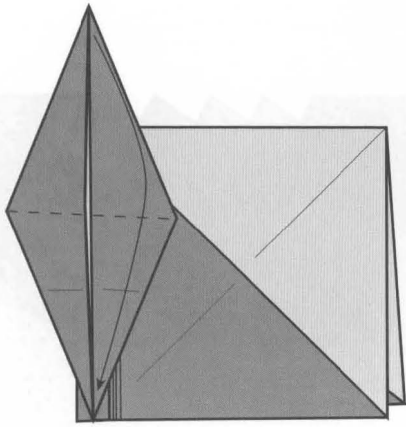

35

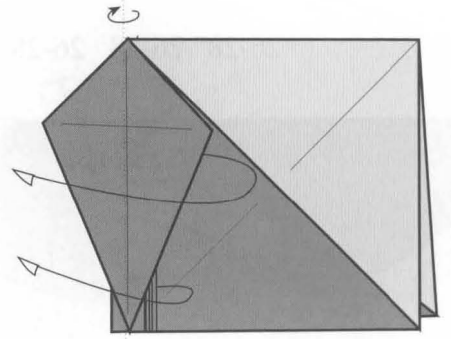

36

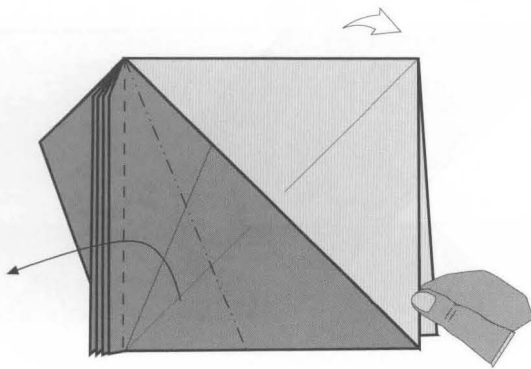

37

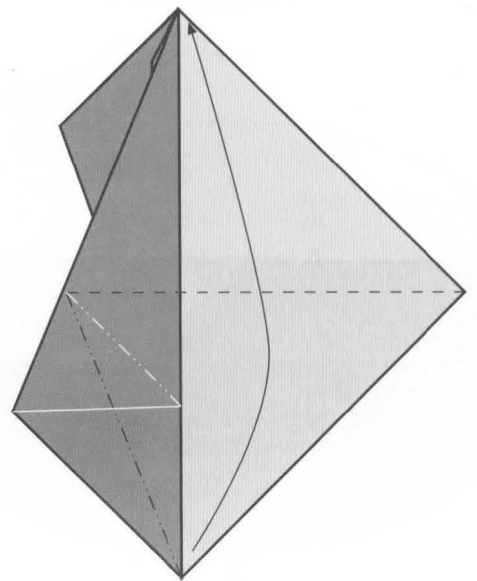

38

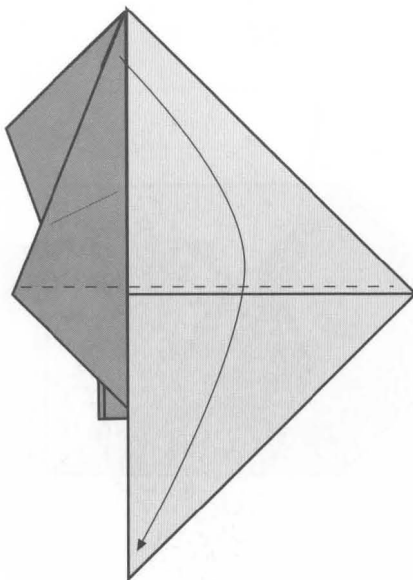

39

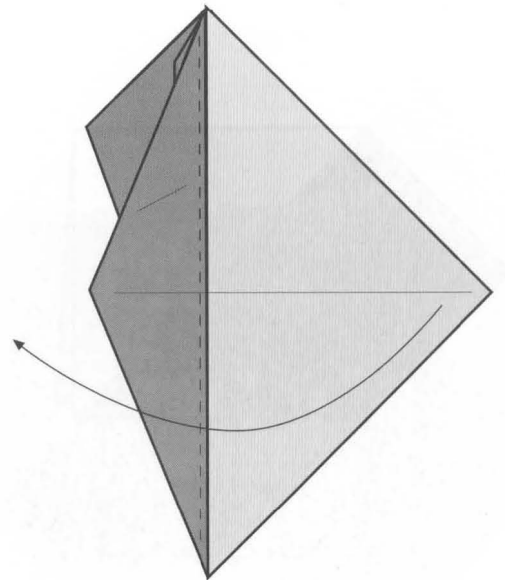

40

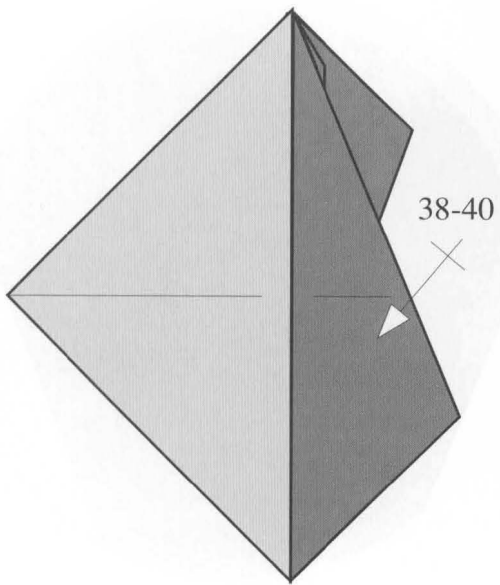

41

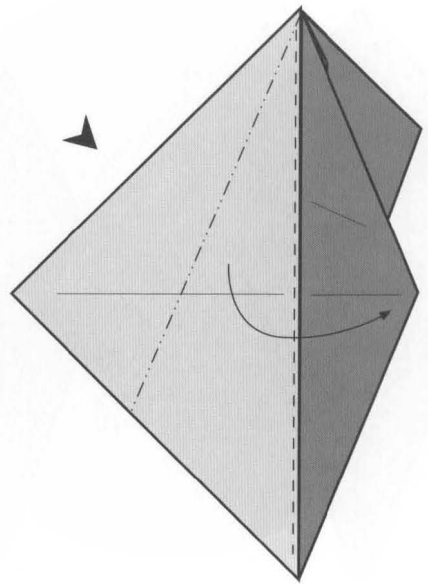

42

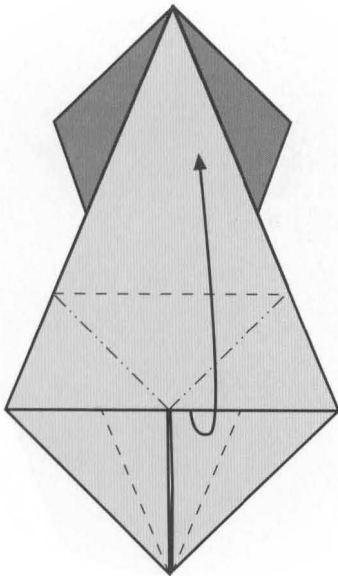

43

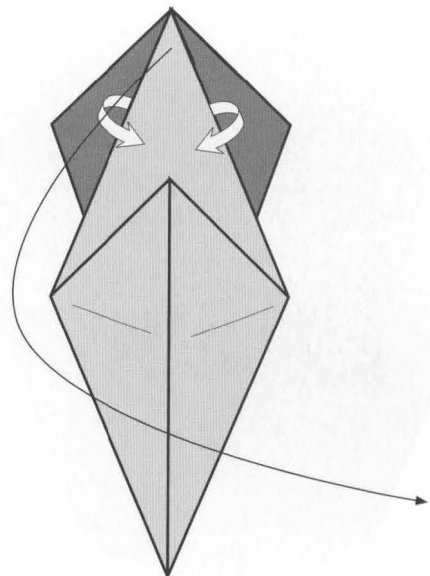

44

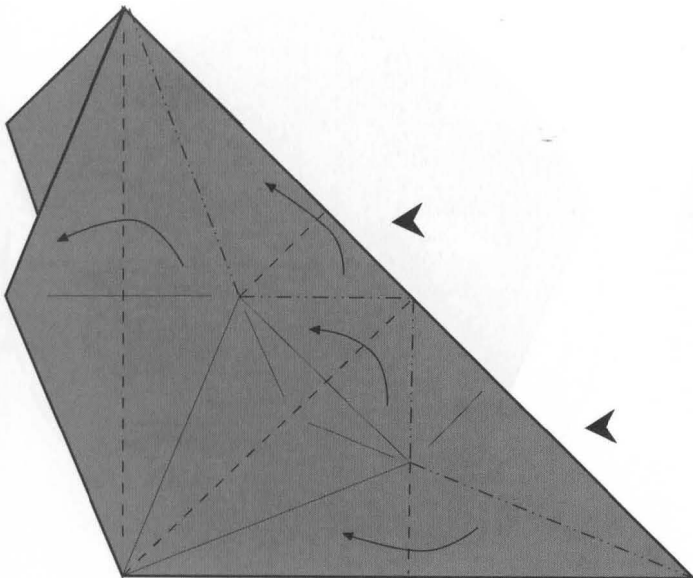

45

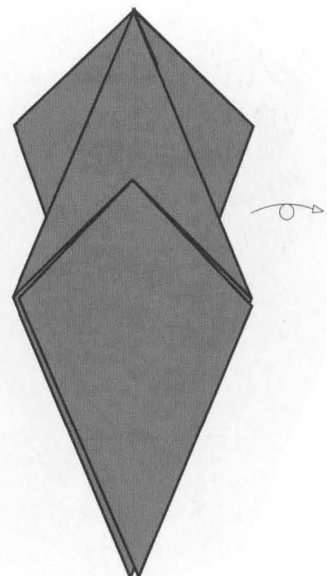

46

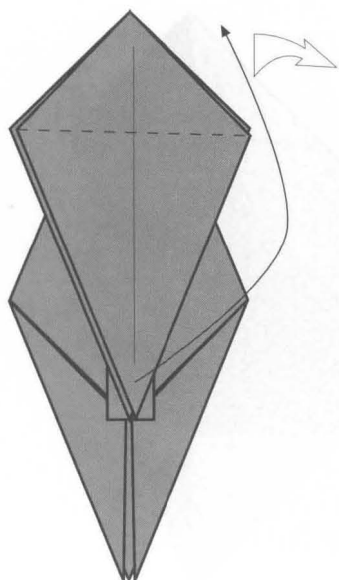

47

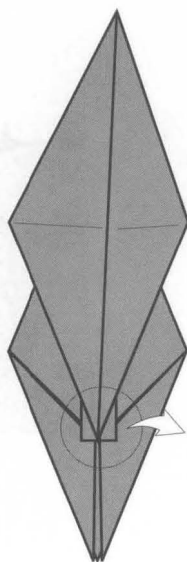

48

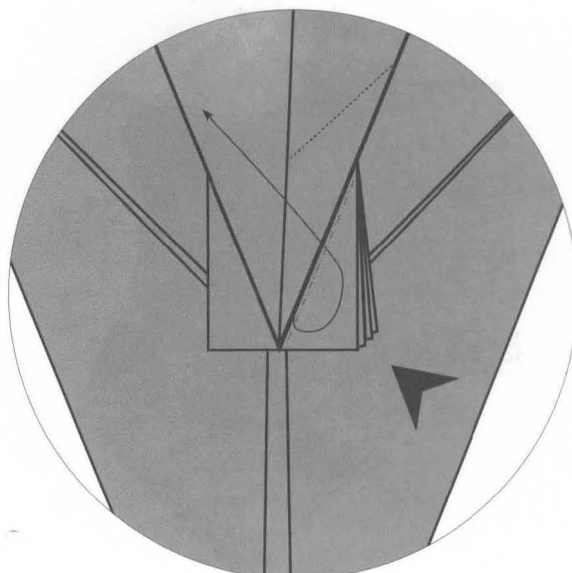

49

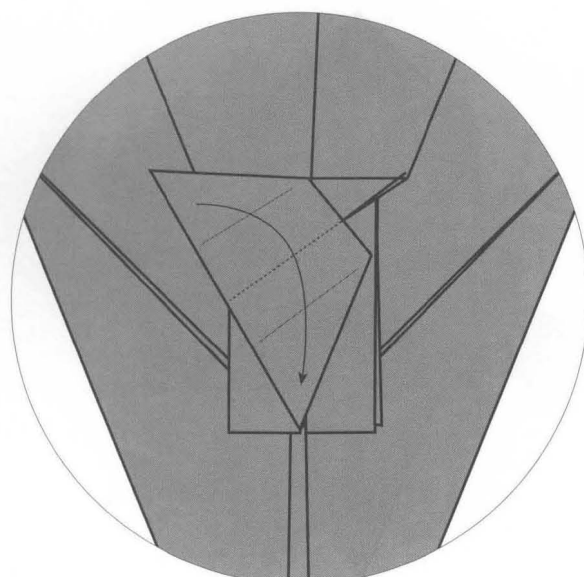

50

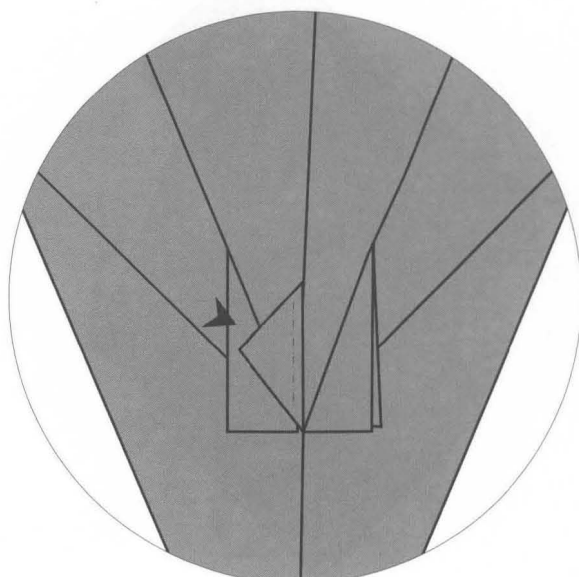

51

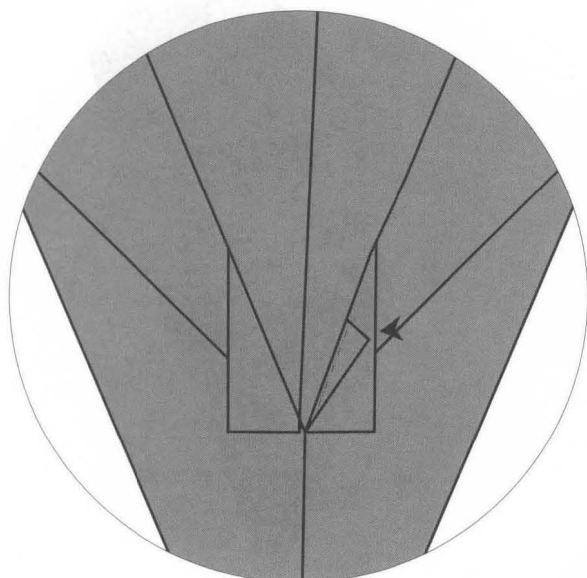

52

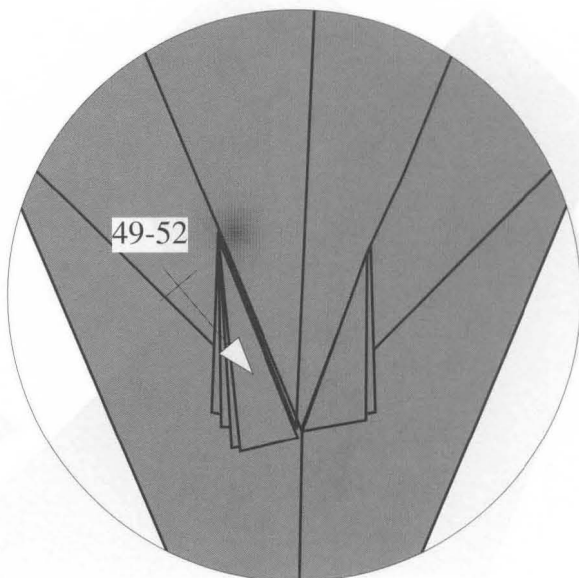

53

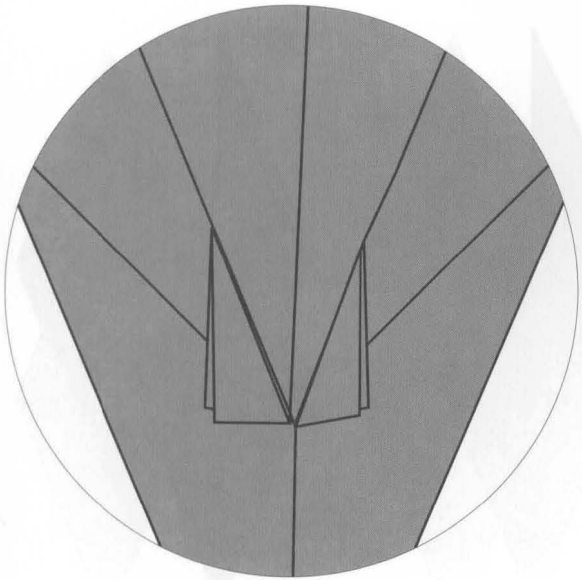

54

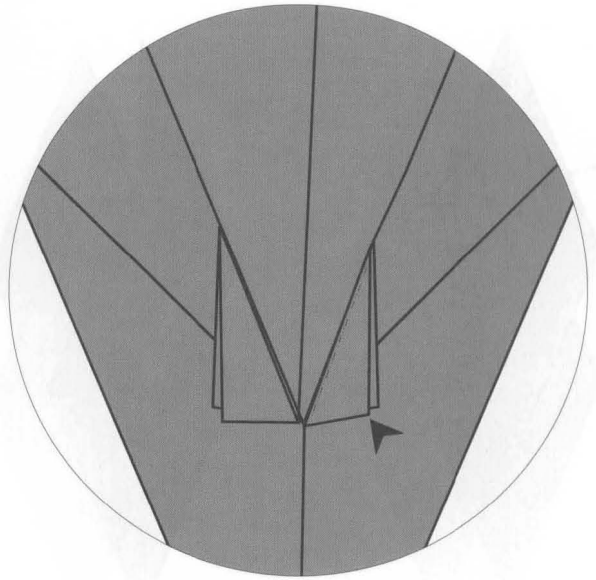

55

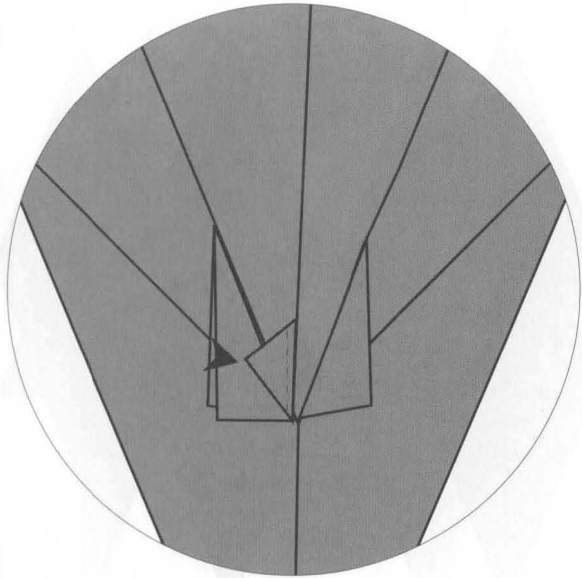

56

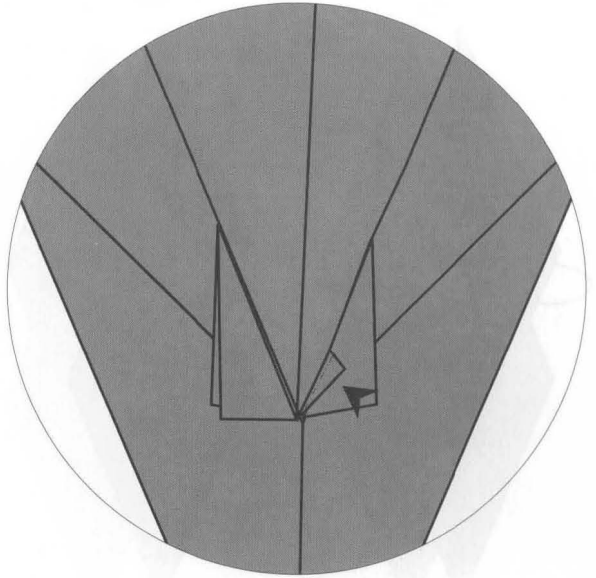

57

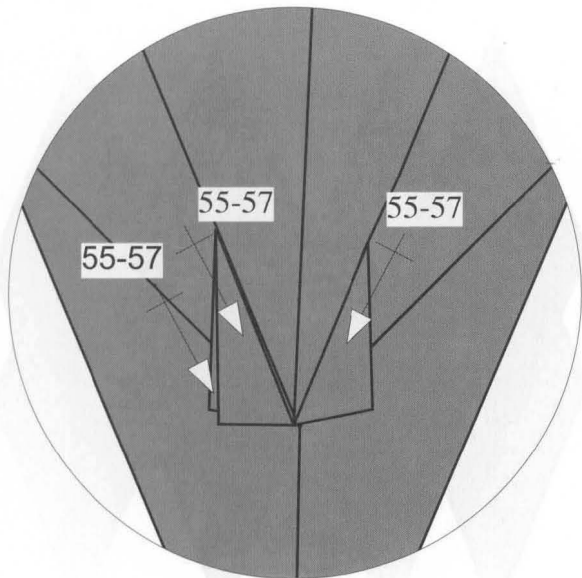

58

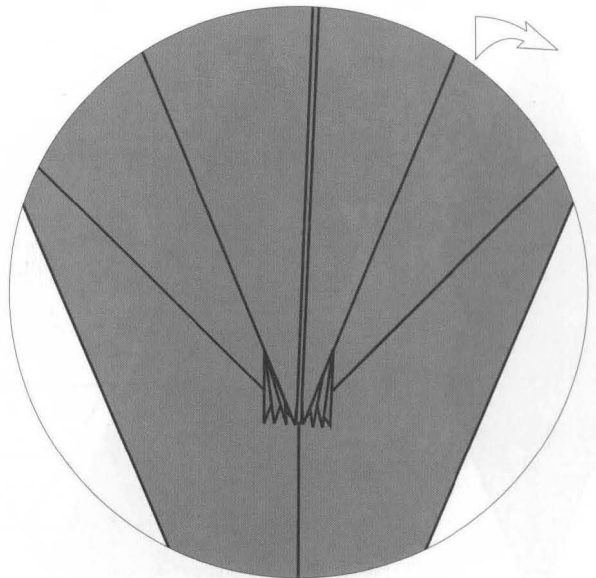

59

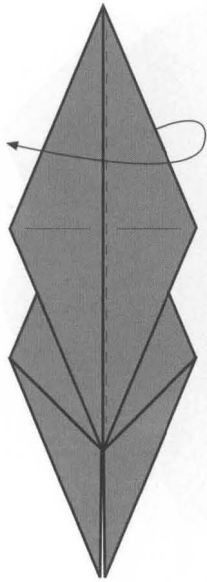

60

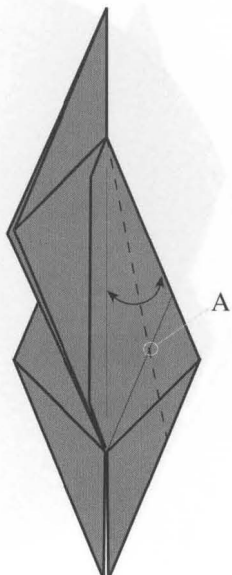

61

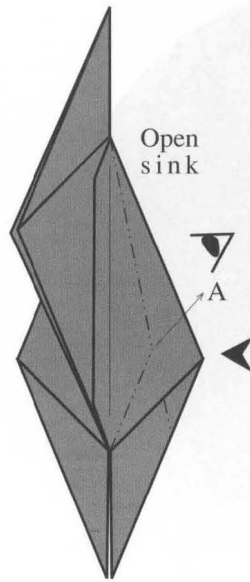

62

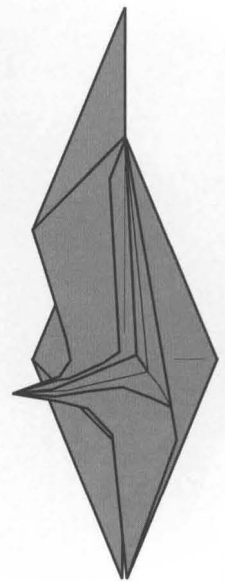

63

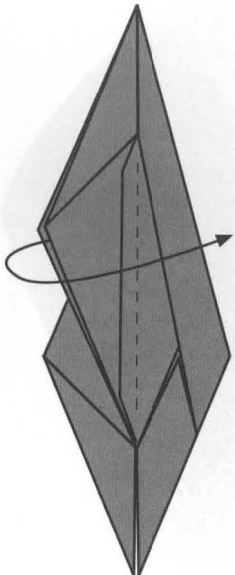

64

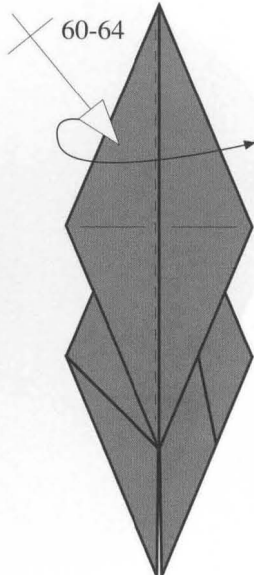

65

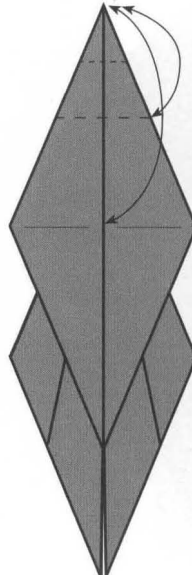

66

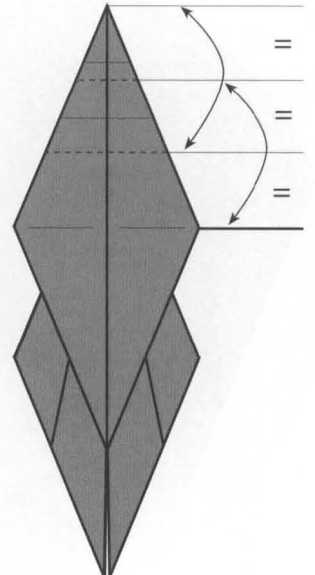

67

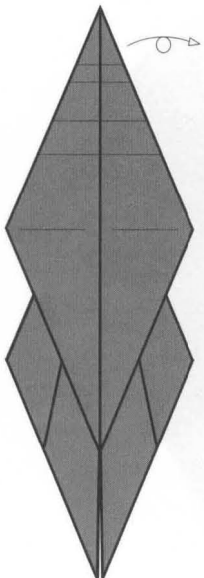

68

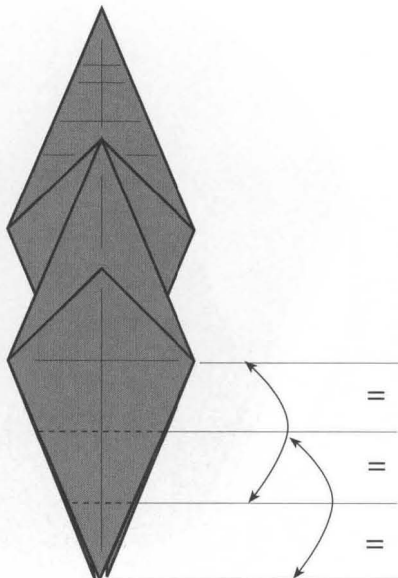

69

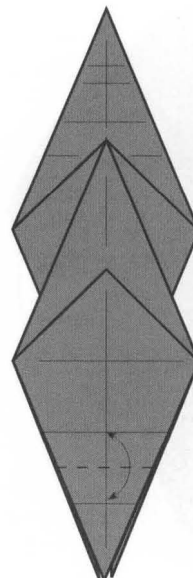

70

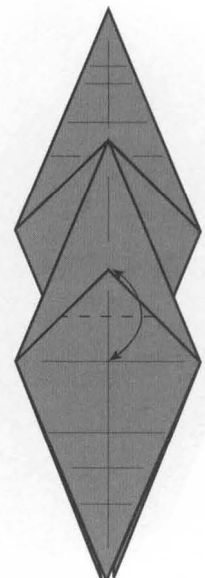

71

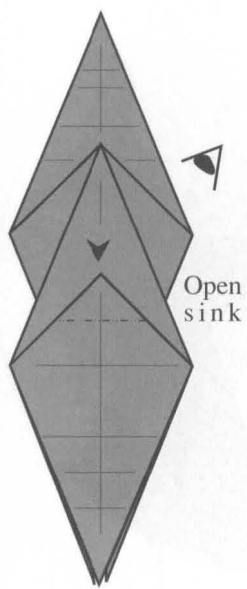

72

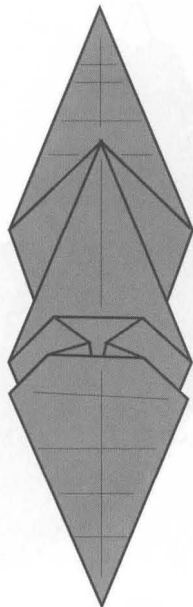

73-3D

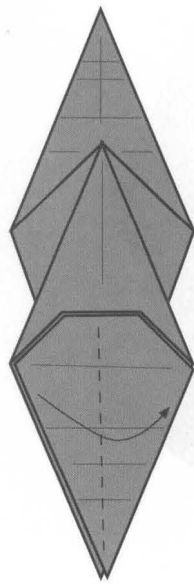

74

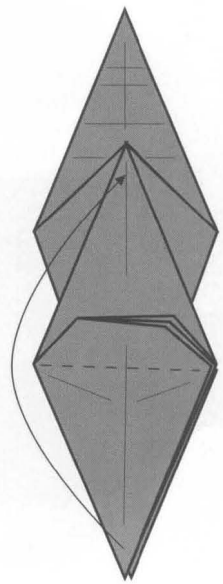

75

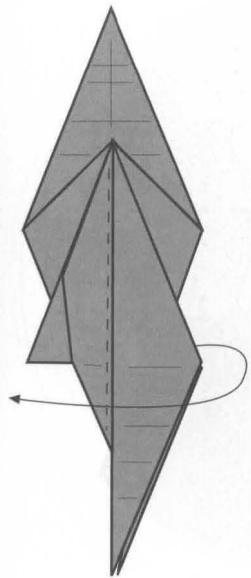

76

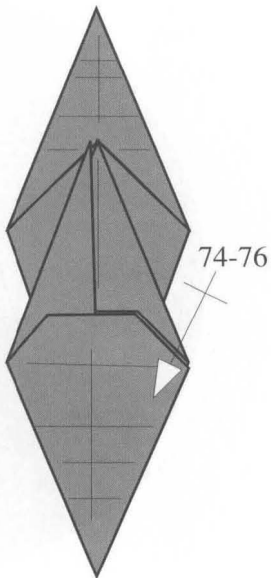

77

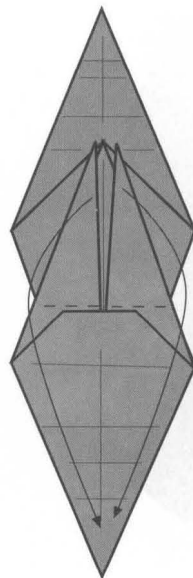

78

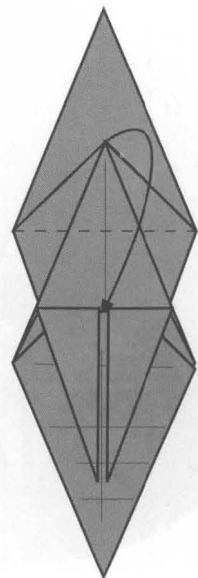

79

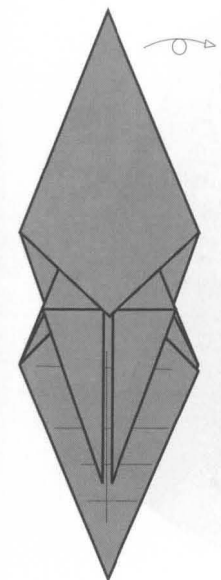

80

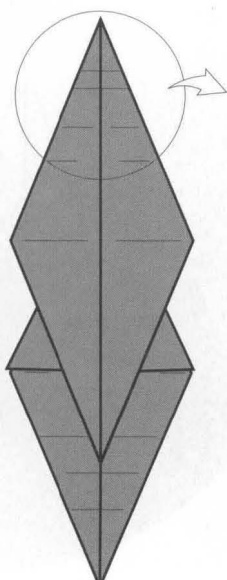

81

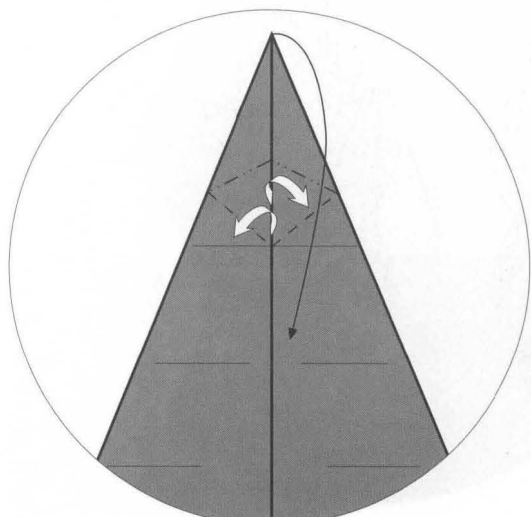

82

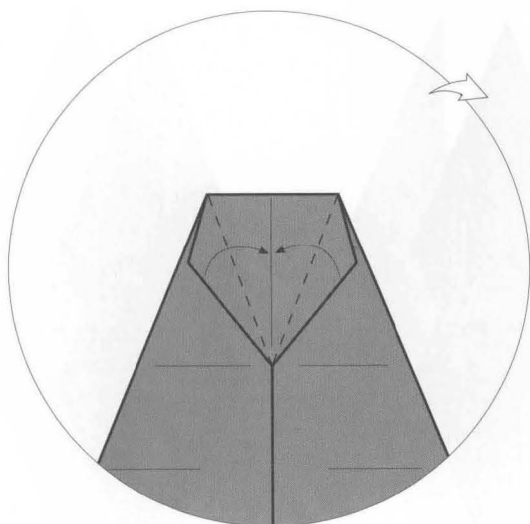

83

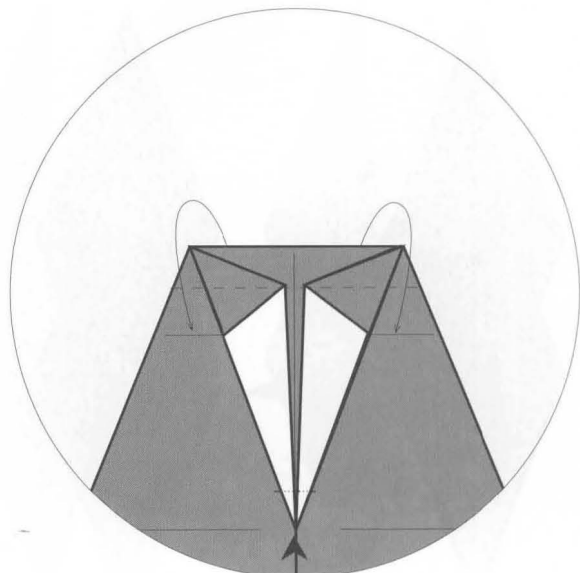

84

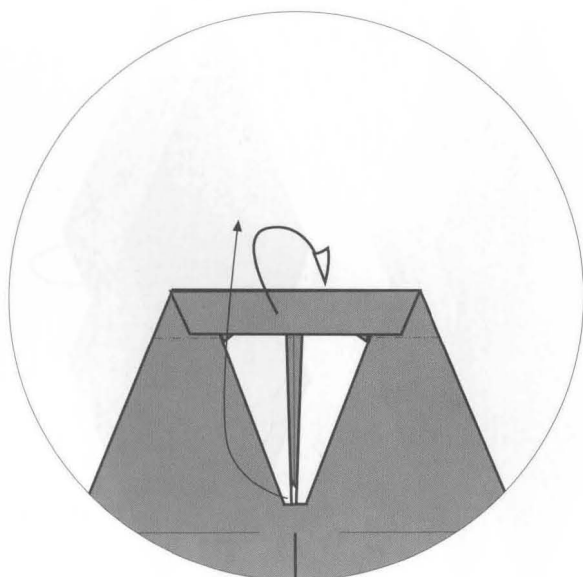

85

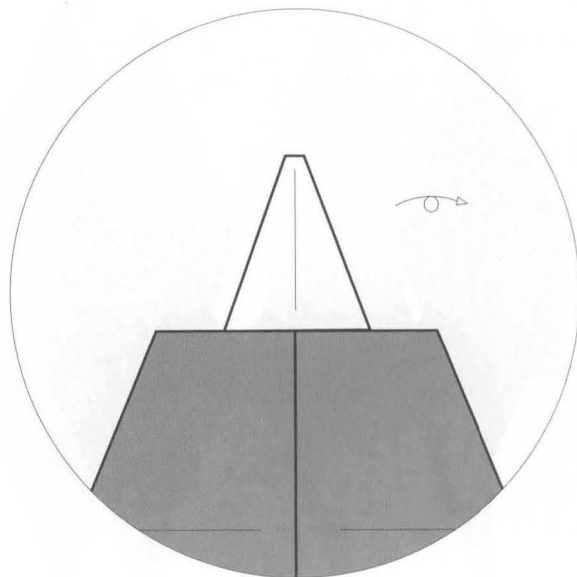

86

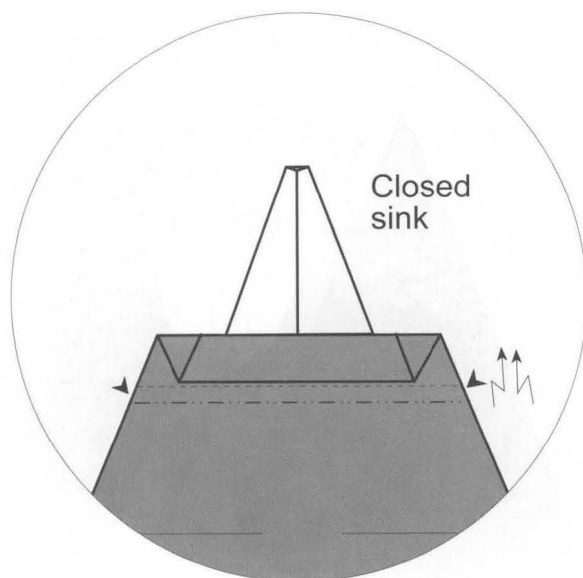

87

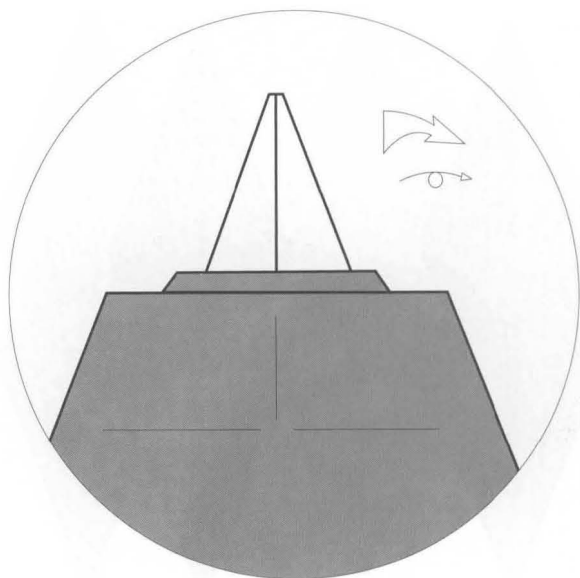

88

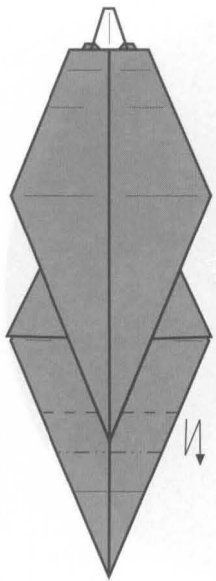

89

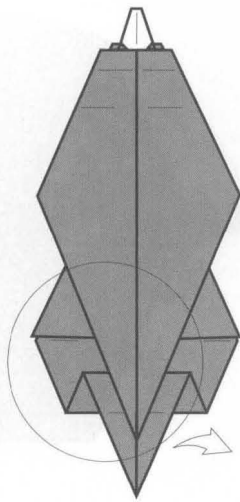

90

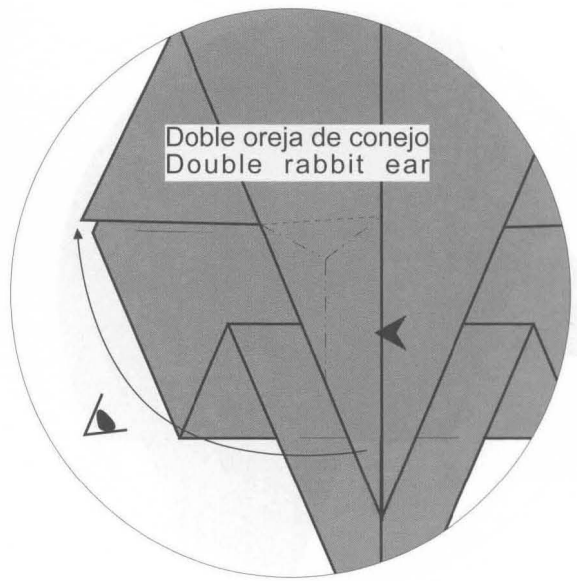

91

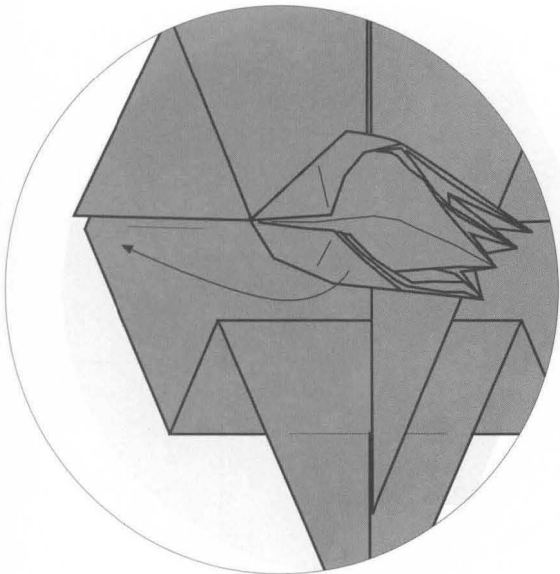

92

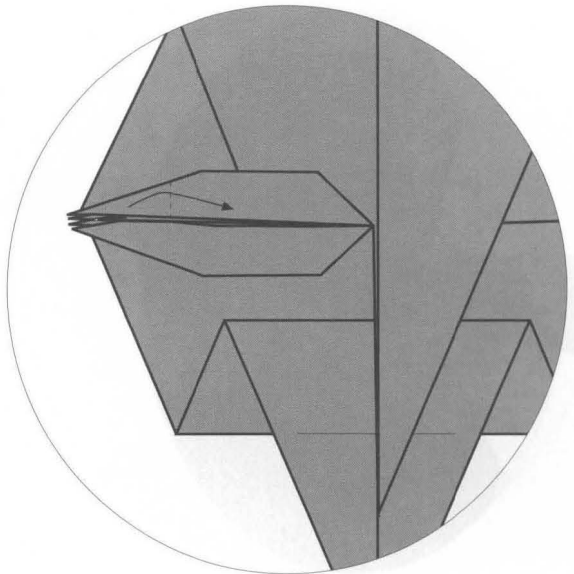

93

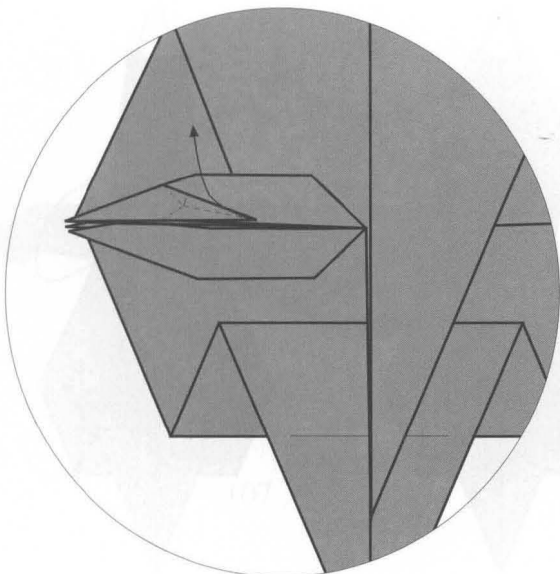

94

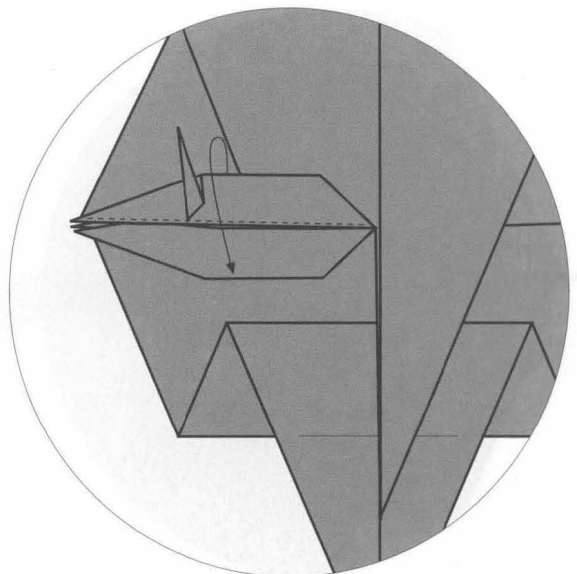

95

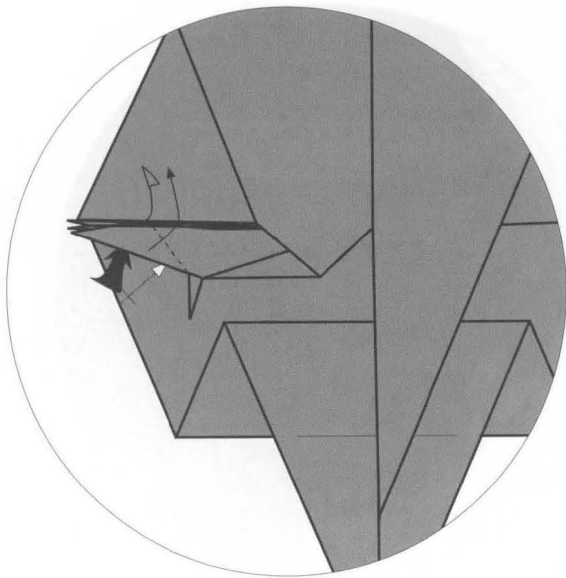

96

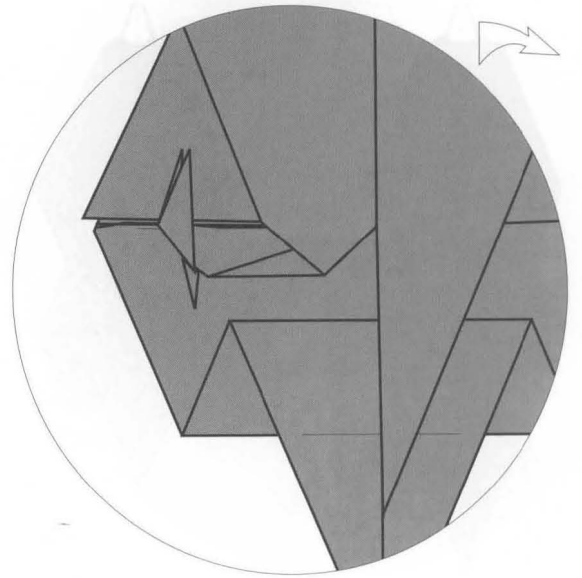

97

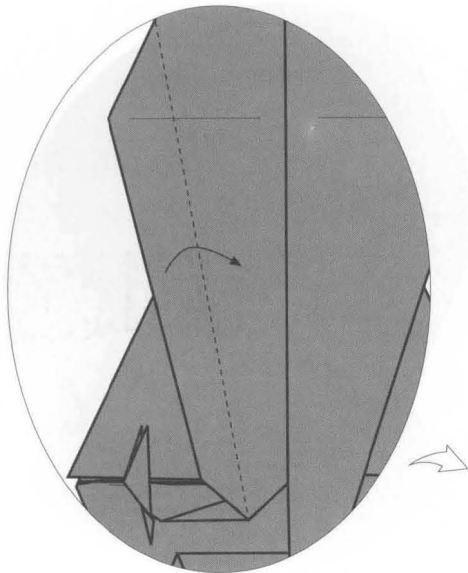

98

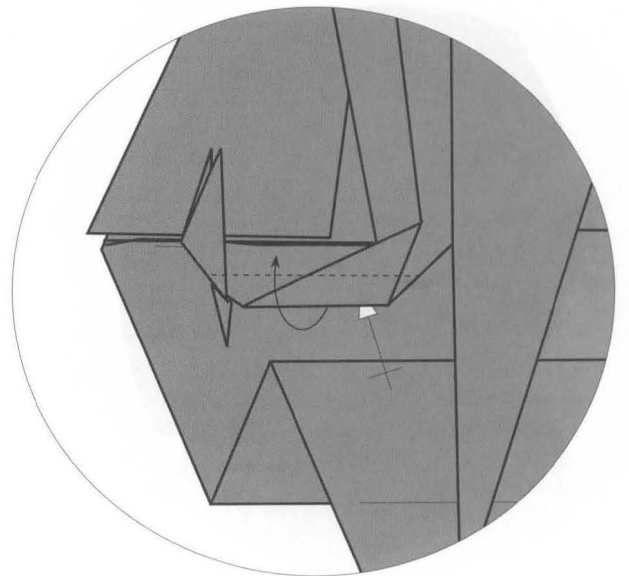

99

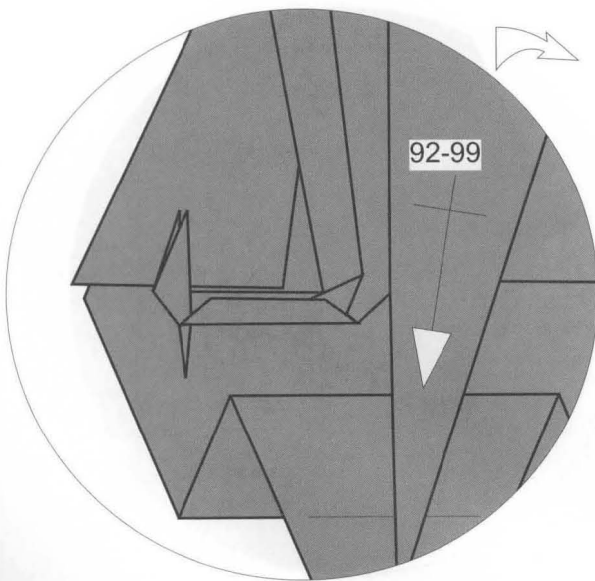

100

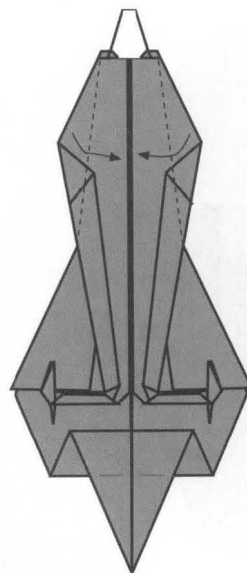

101

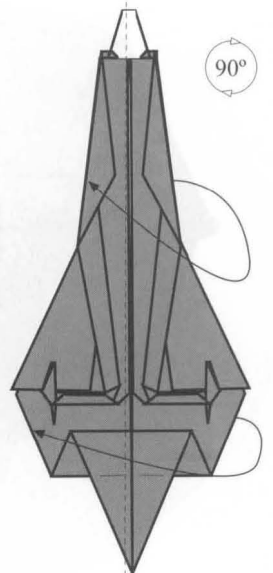

102

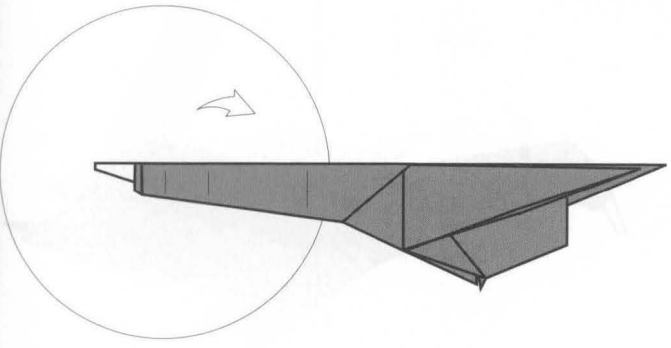

103

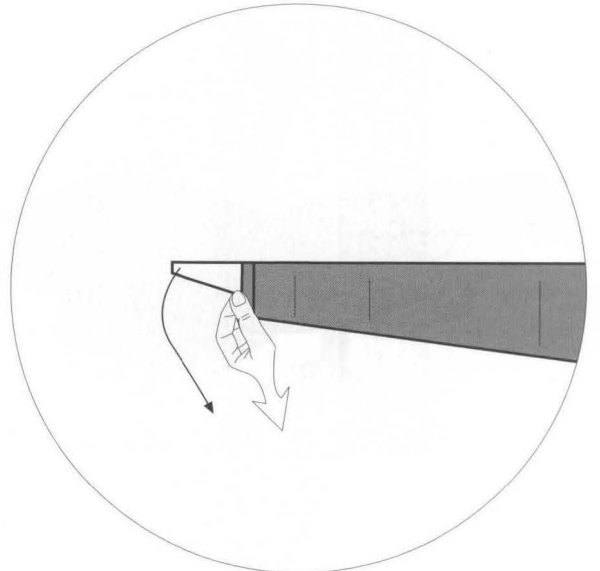

104

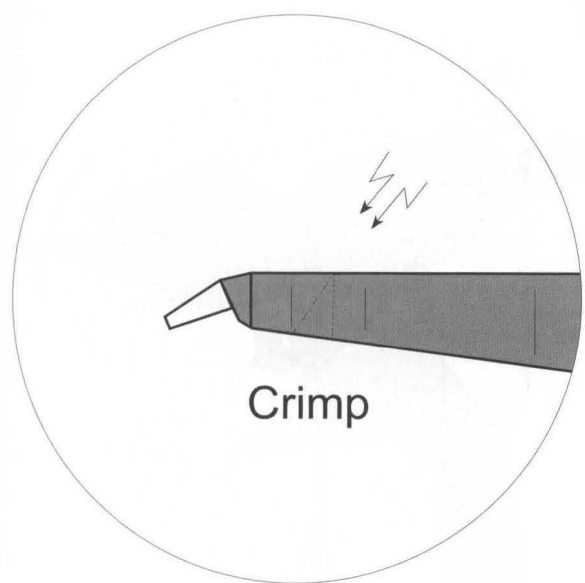

Crimp

105

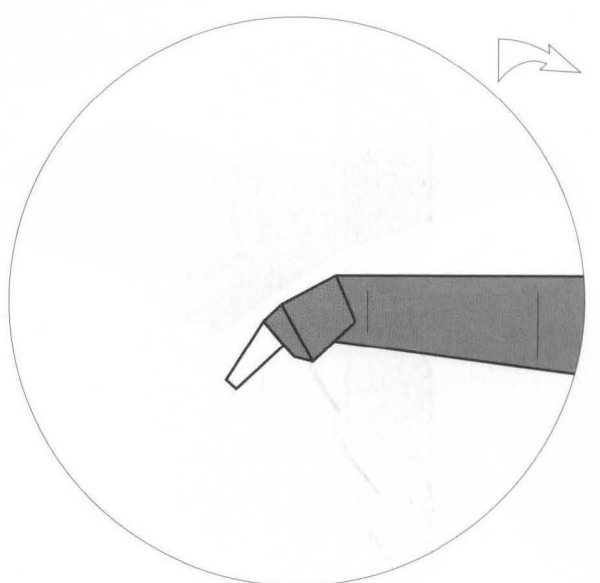

106

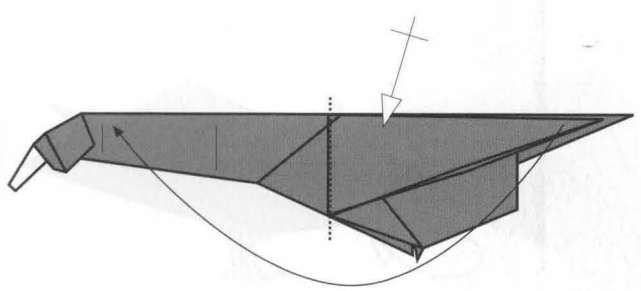

107

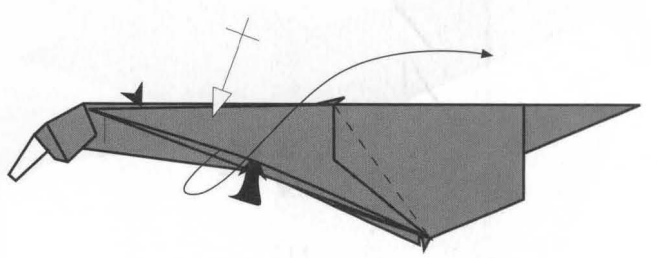

108

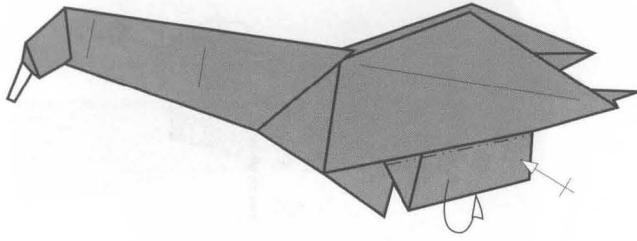

109

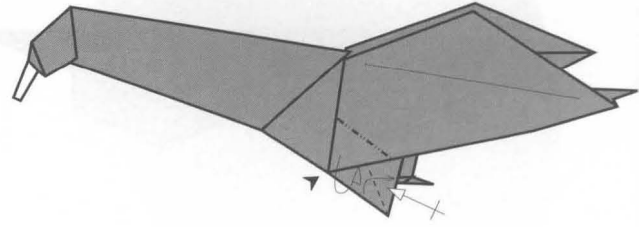

110

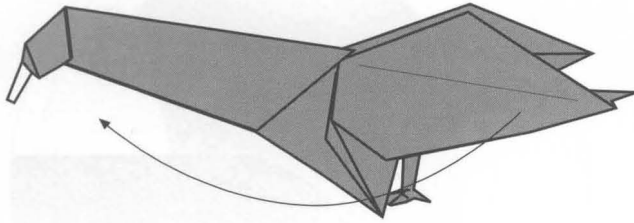

111

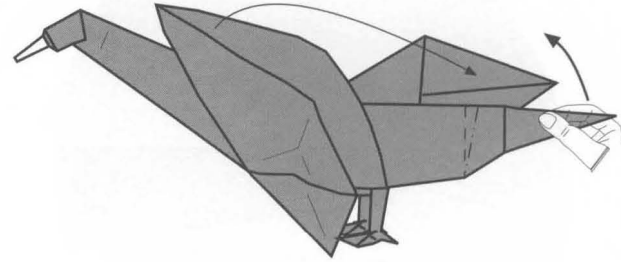

112

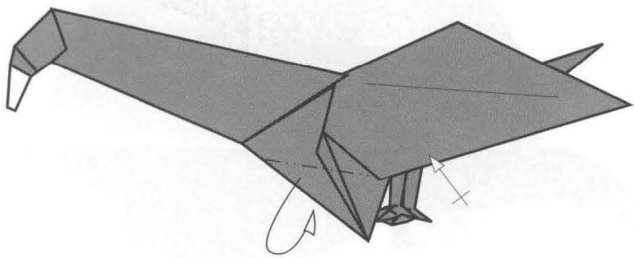

113

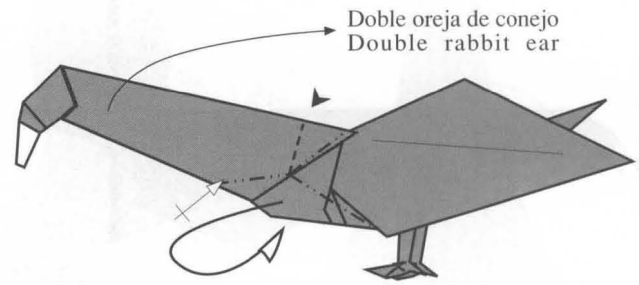

Doble oreja de conejo
Double rabbit ear

114

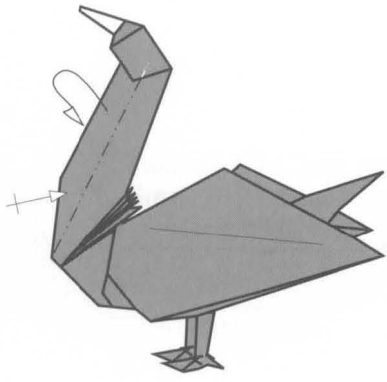

115

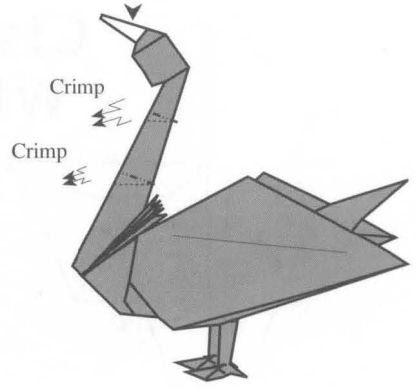

116

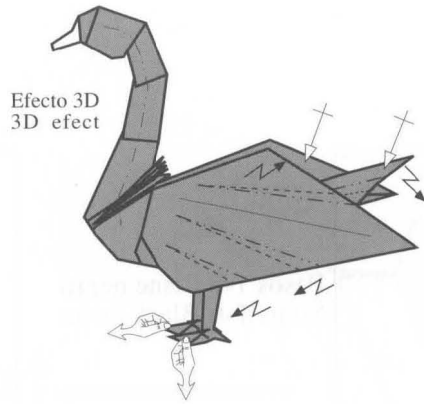

117

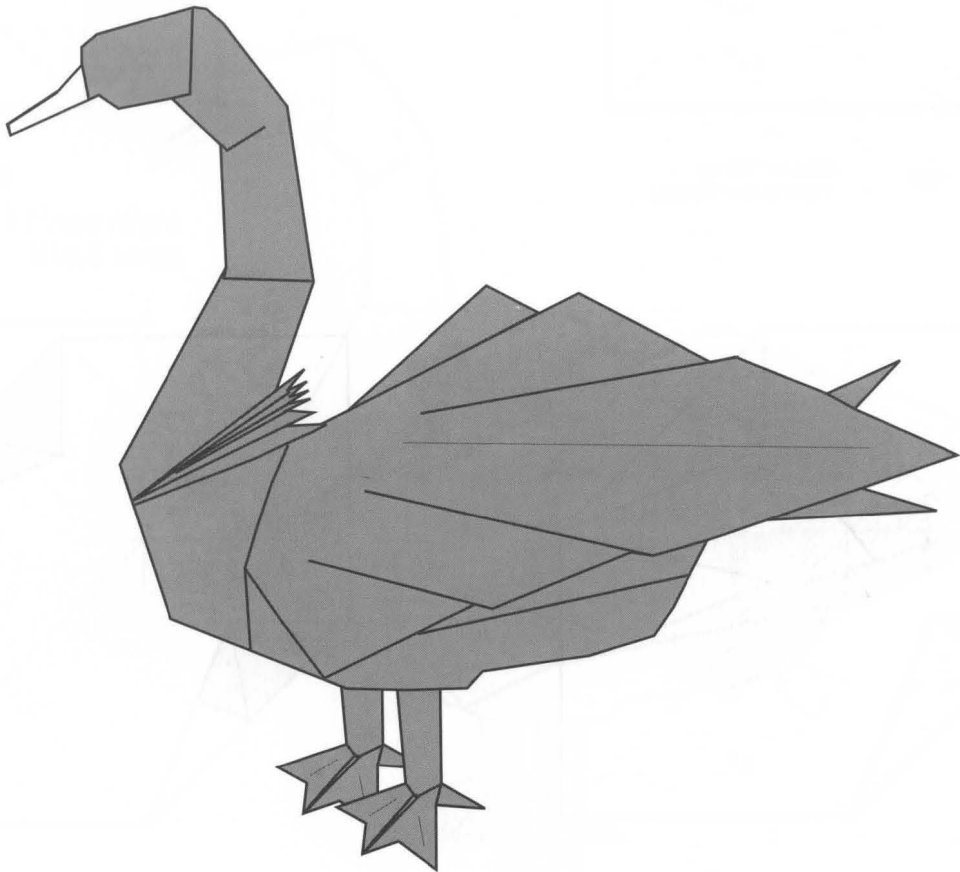

118

Cisne blanco White swan

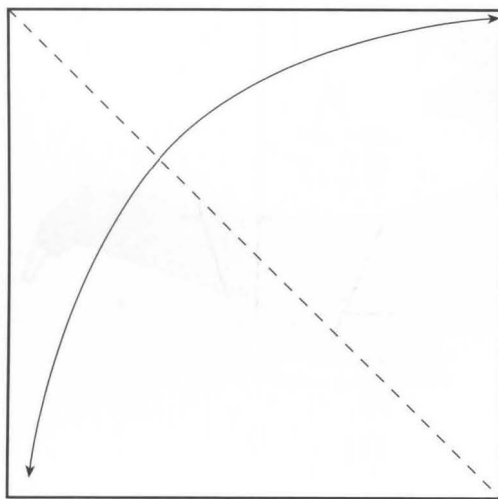

Pasos 1-6 Cisne negro
Steps 1-6 Black swan

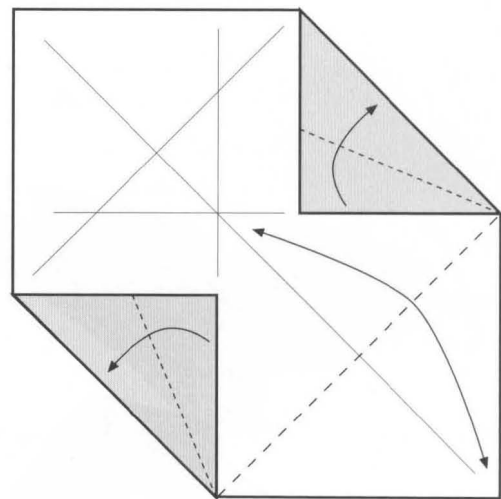

1 

Blanco / White
Anaranjado / Orange

7-A

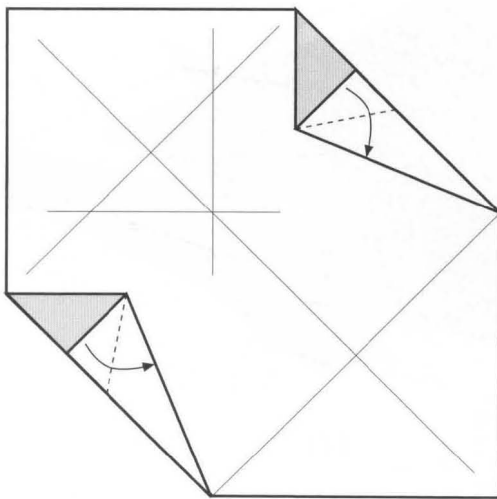

7-B

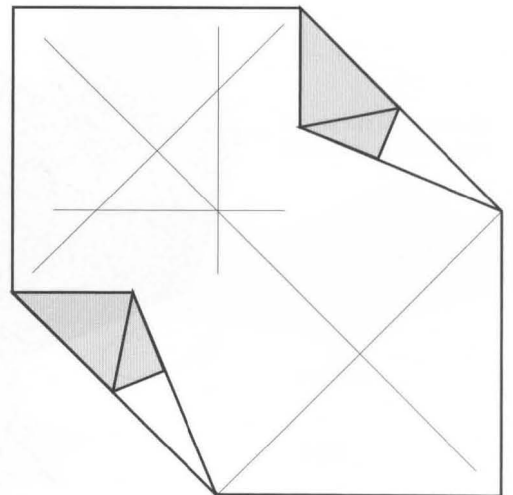

7-C

Pasos 8-92 Cisne negro
Steps 8-92 Black swan

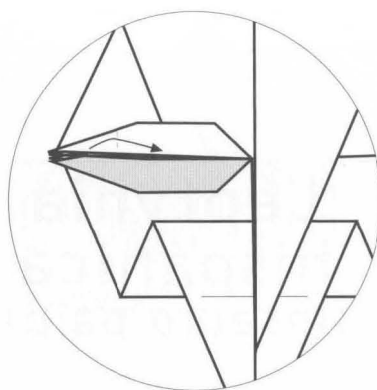

93

Pasos 94-98 Cisne negro
Steps 94-98 Black swan

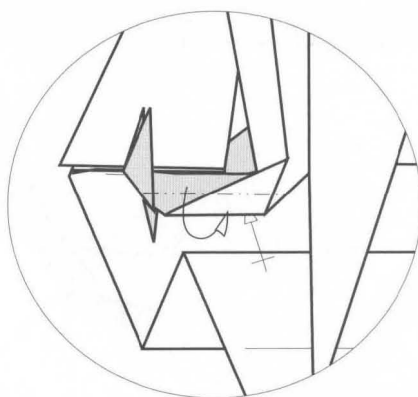

99

Pasos 100-117 Cisne negro
Steps 100-117 Black swan

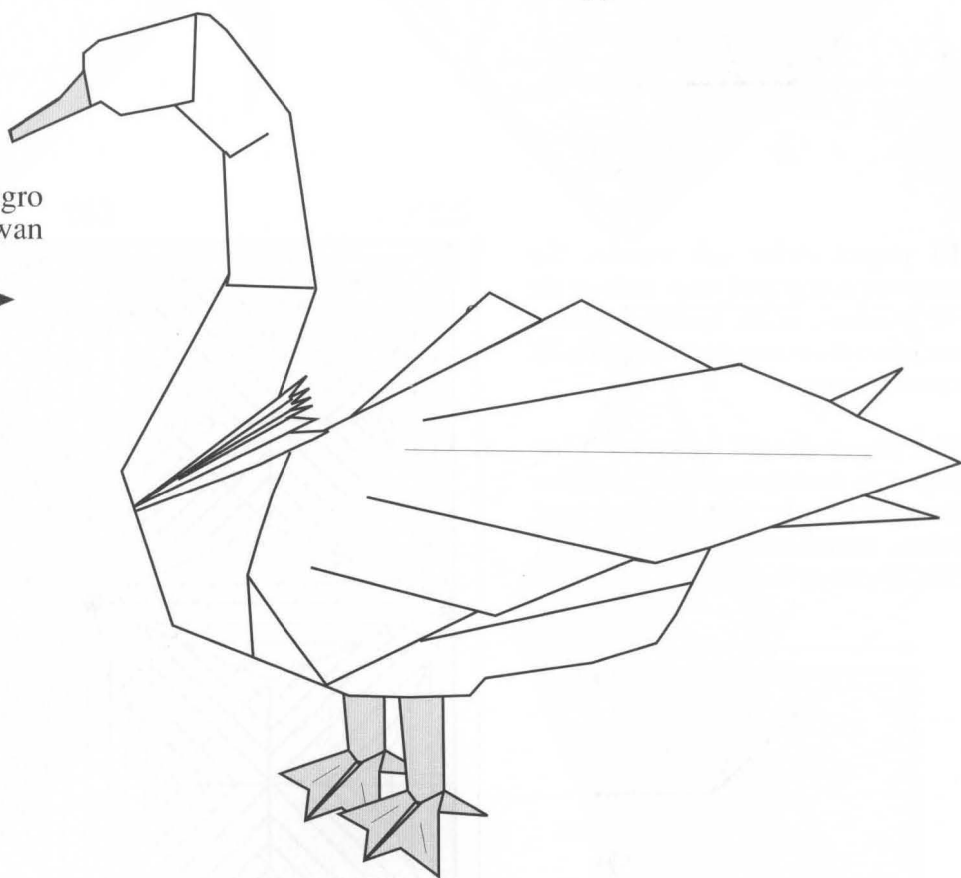

118

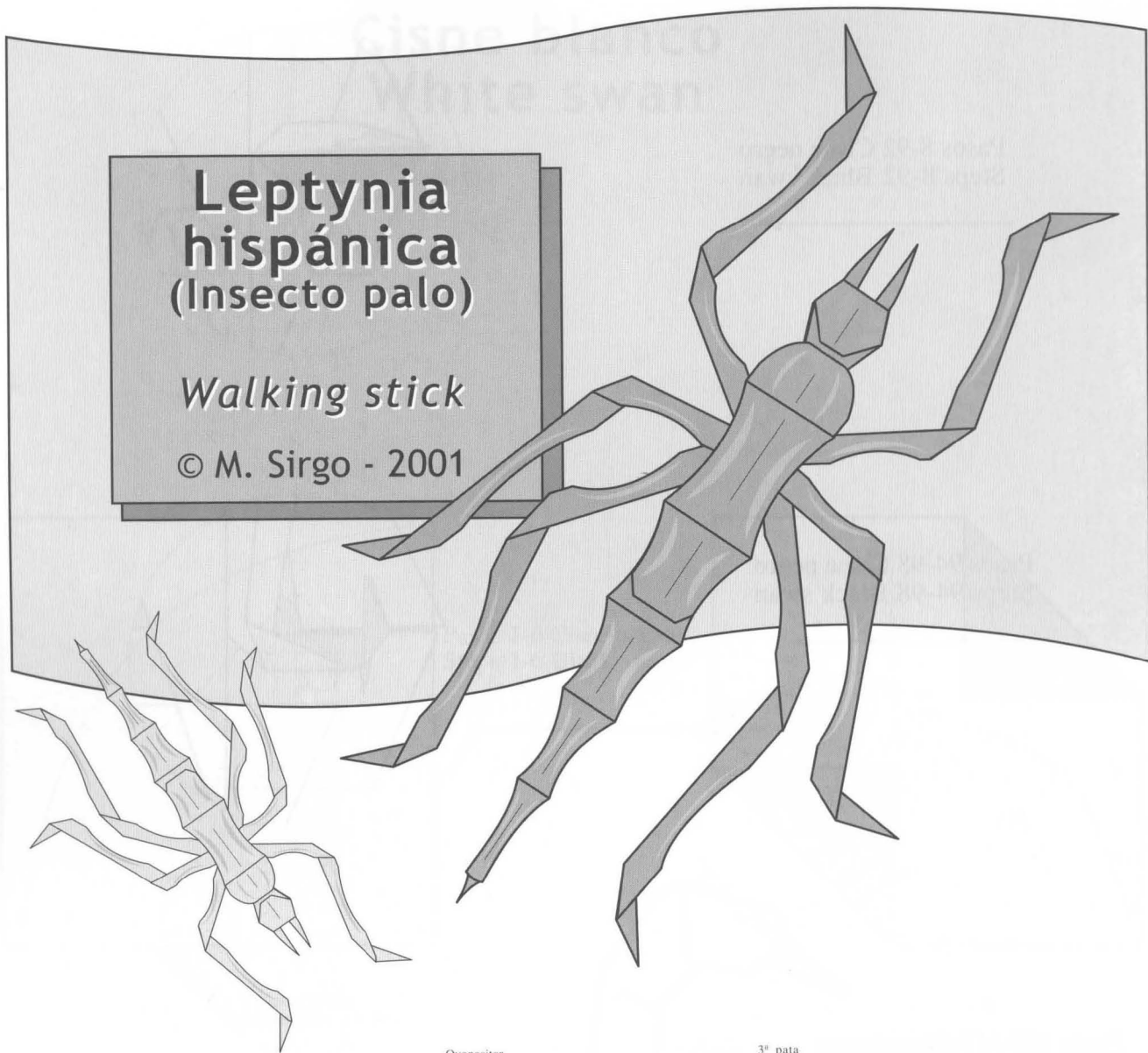

El papel debe ser verde. Se recomienda papel fino, menor de 30 gramos, seda, banano, lokta, metalizado o *sandwich* de 20x20 cm o mayor.

The paper should be green. Fine paper is recommended, smaller than 30 grams, silk, banana tree, lokta, metalized or sandwich of 20x20 cm or bigger.

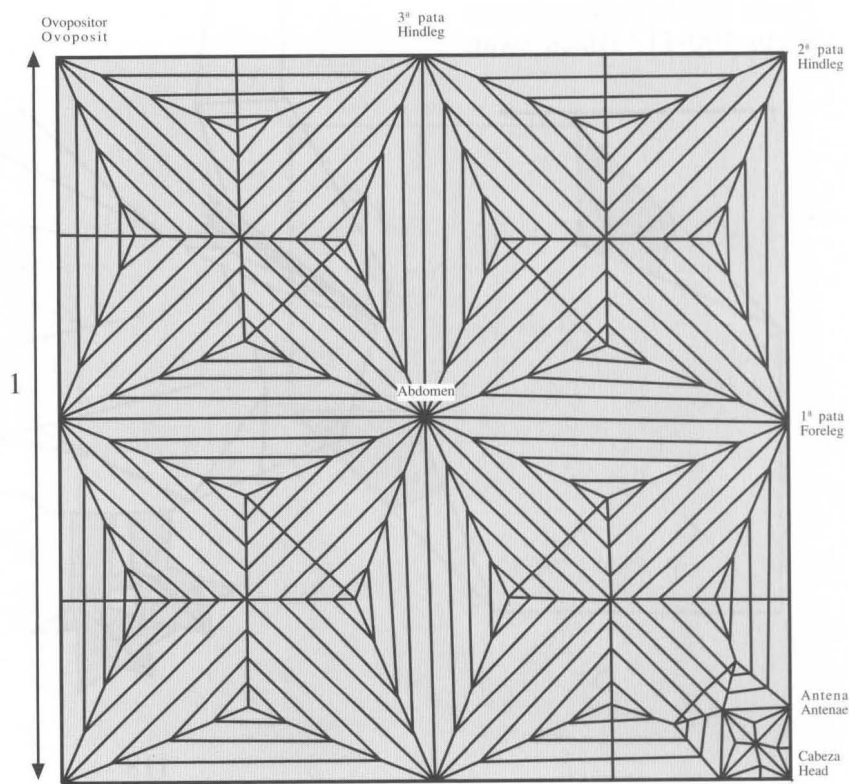
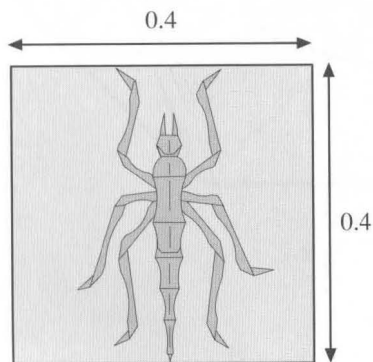

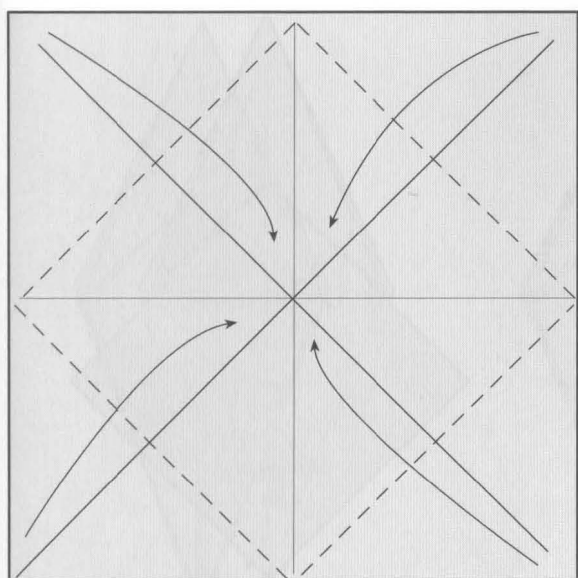

1

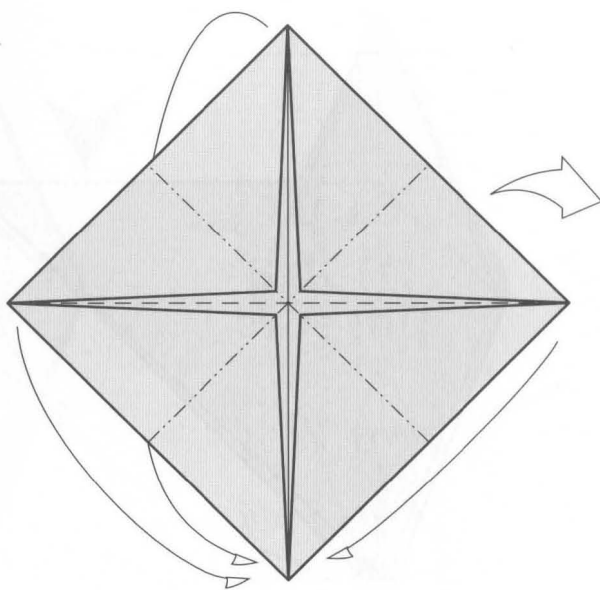

2

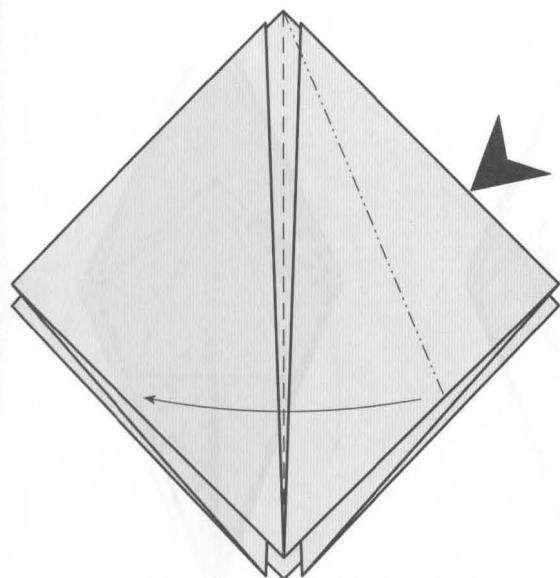

3

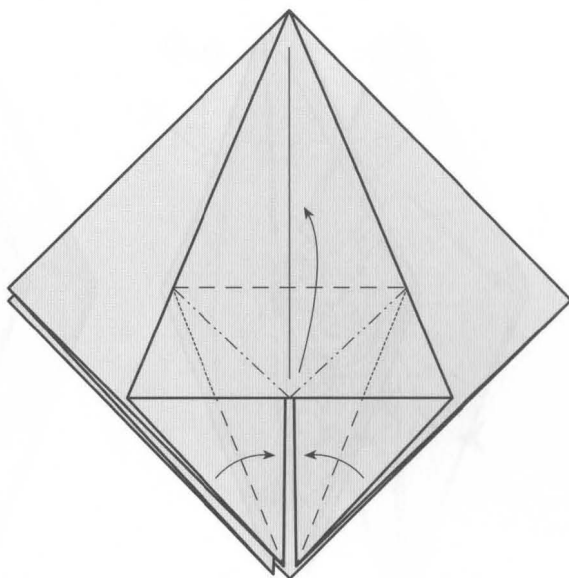

4

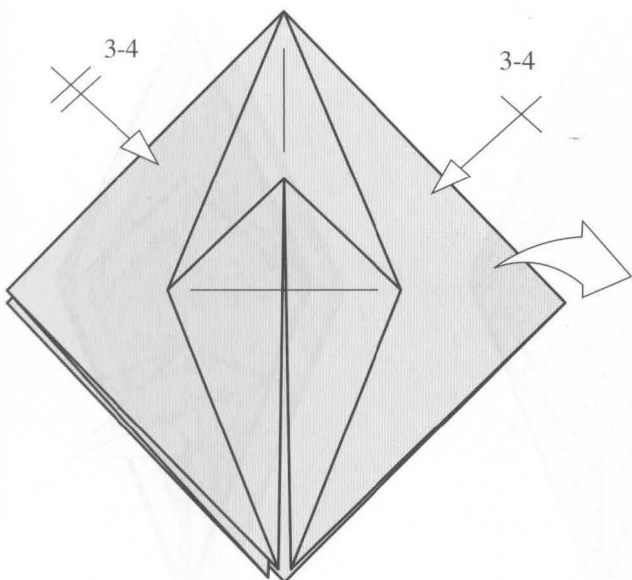

5

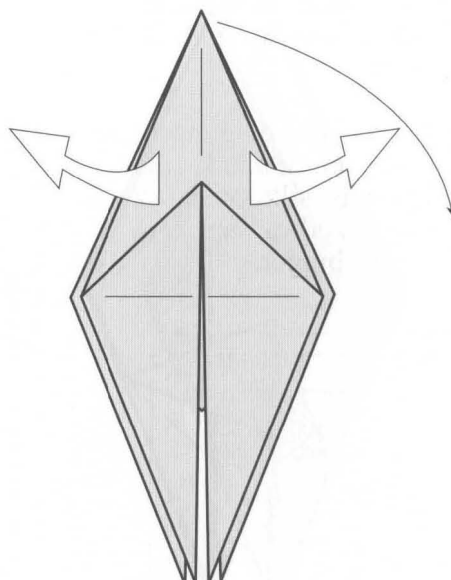

6

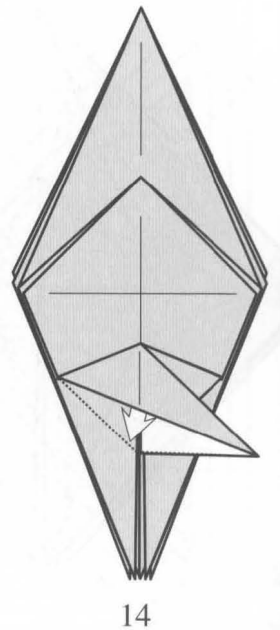
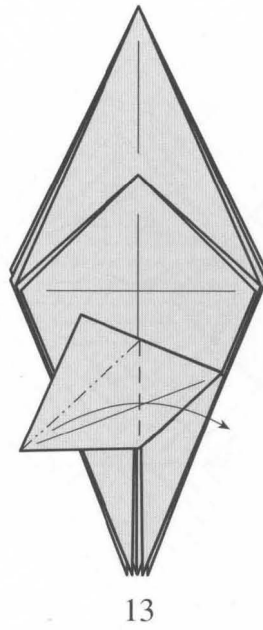
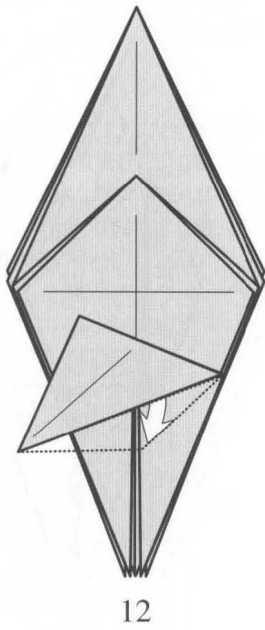
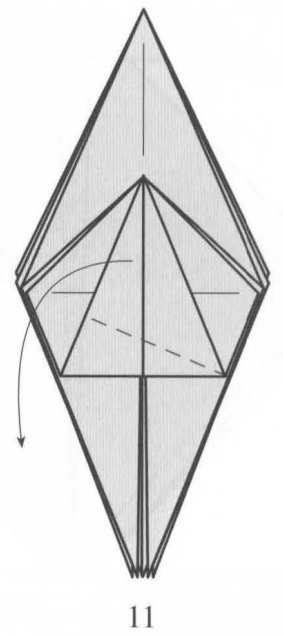
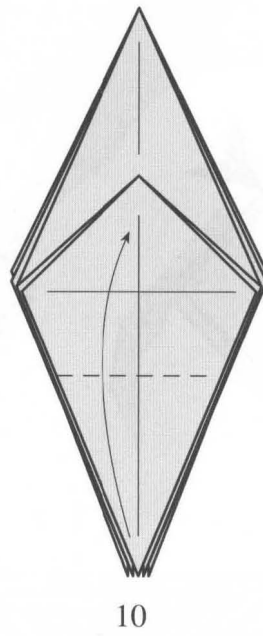
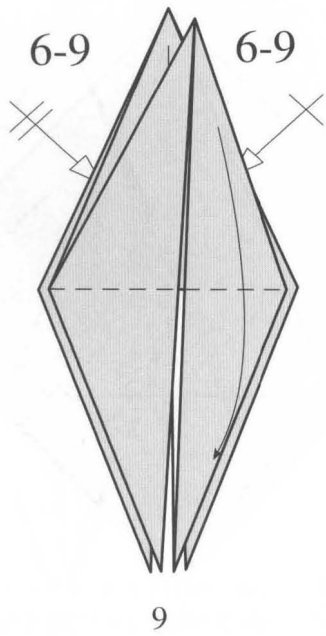
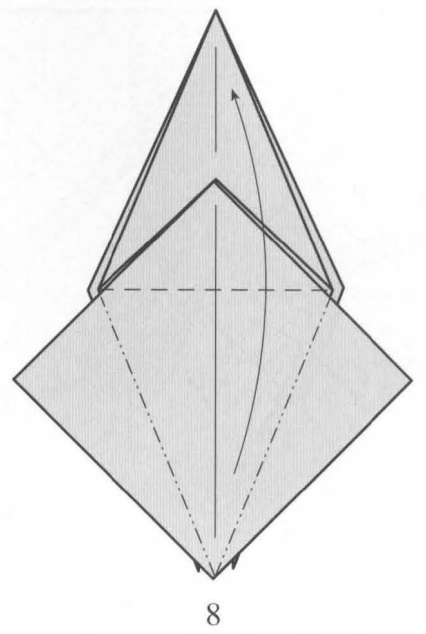
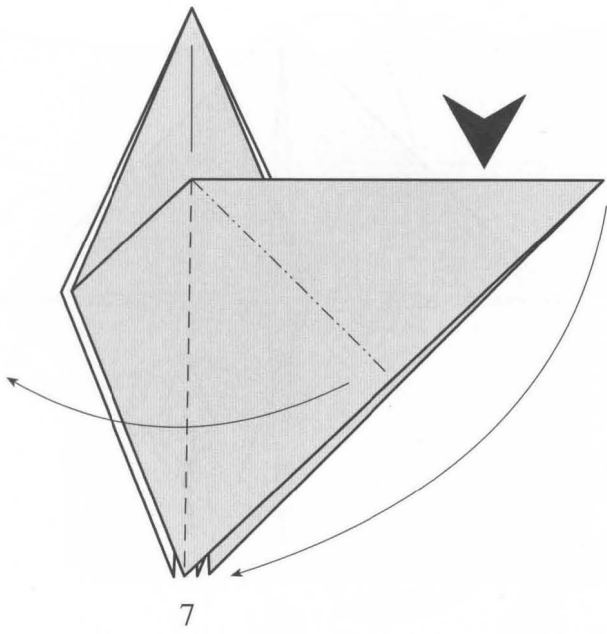

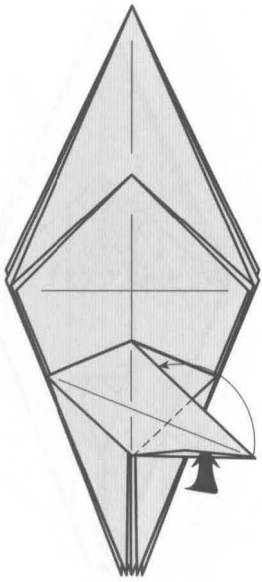

15

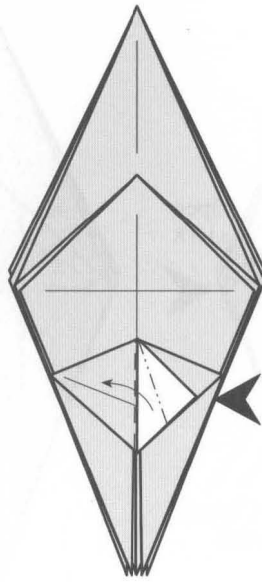

16

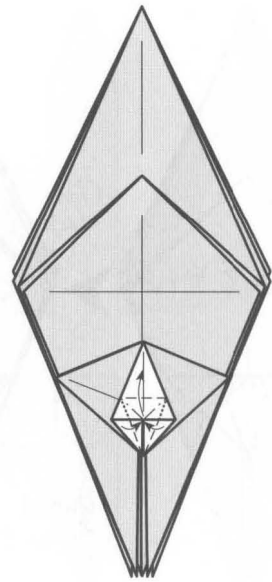

17

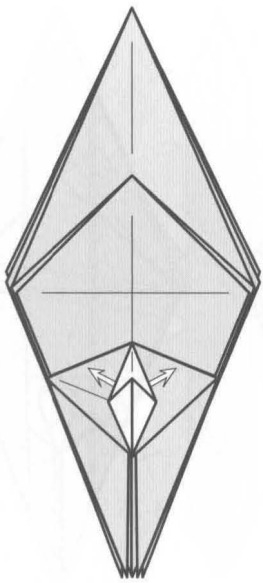

18

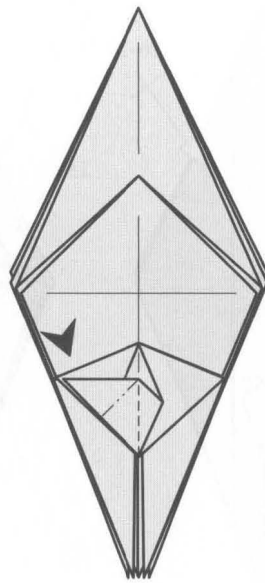

19

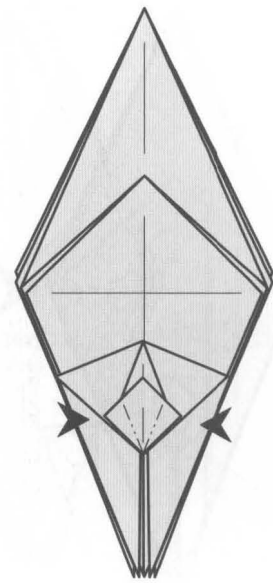

20

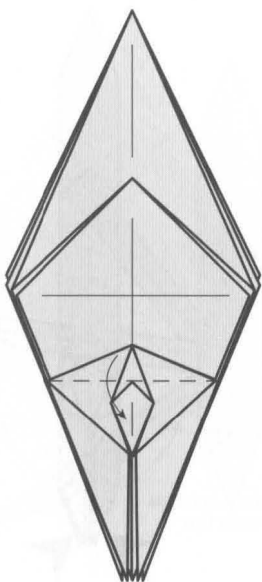

21

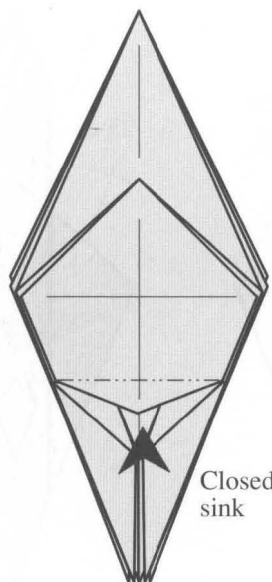

22

Closed sink

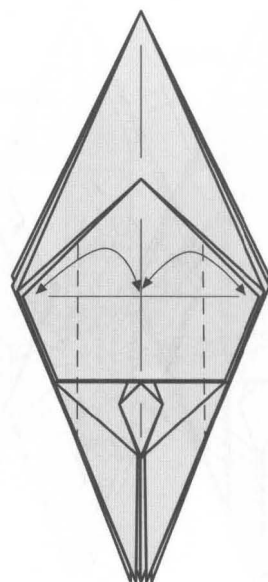

23

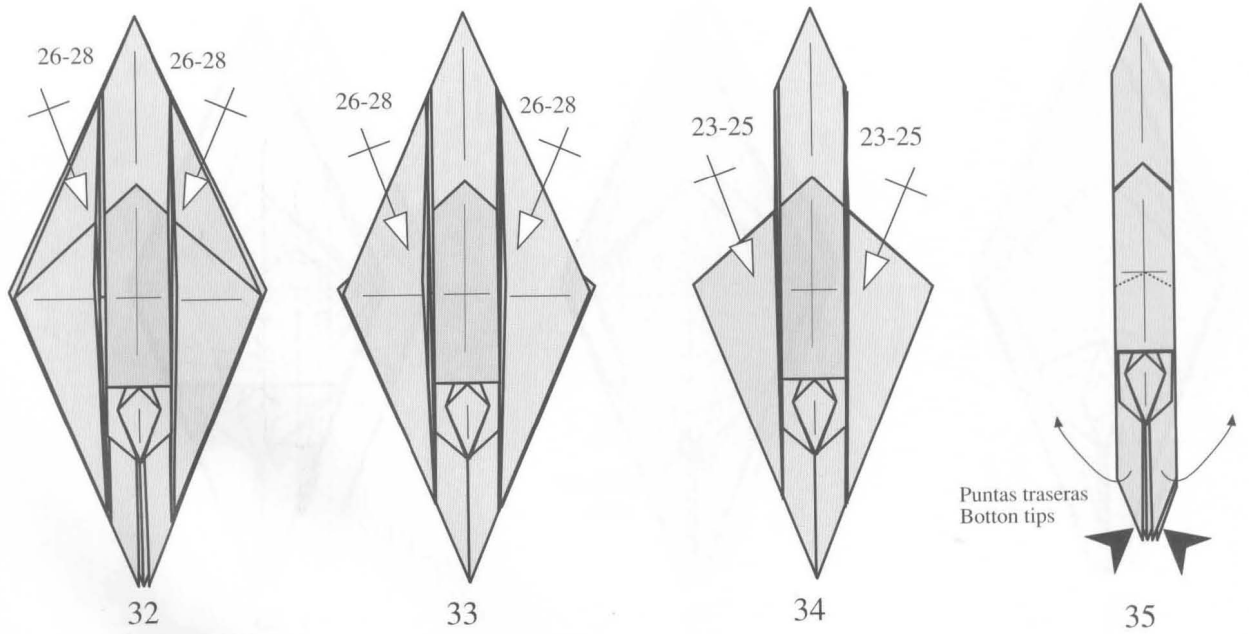
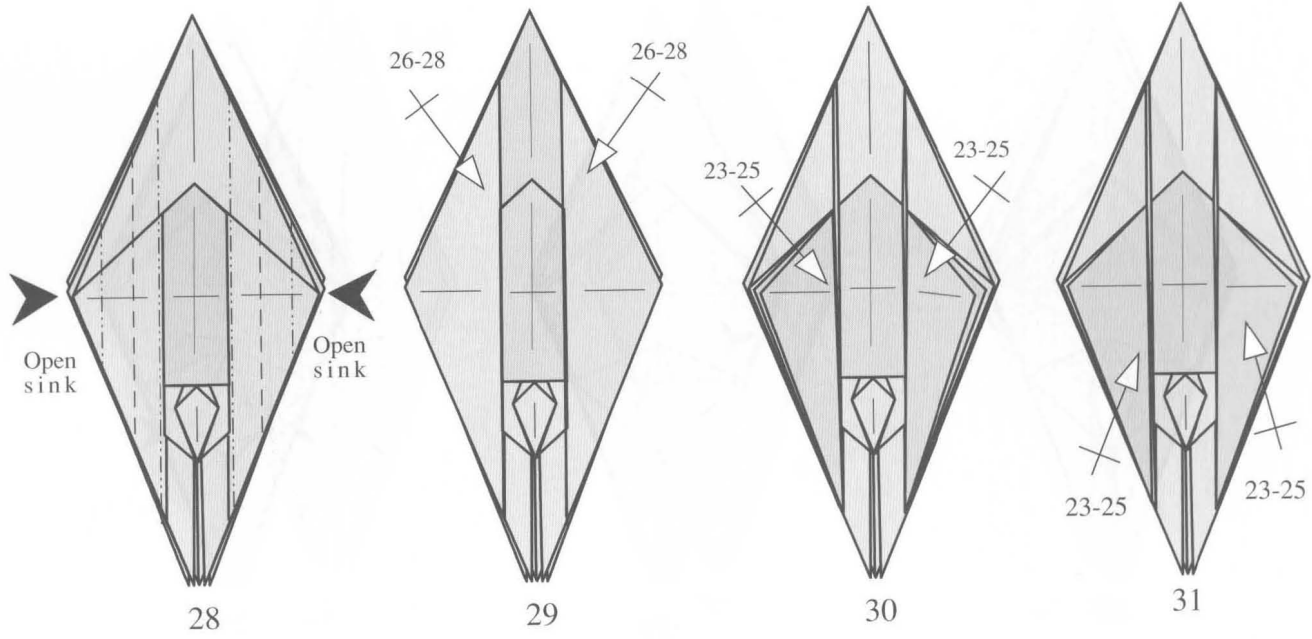
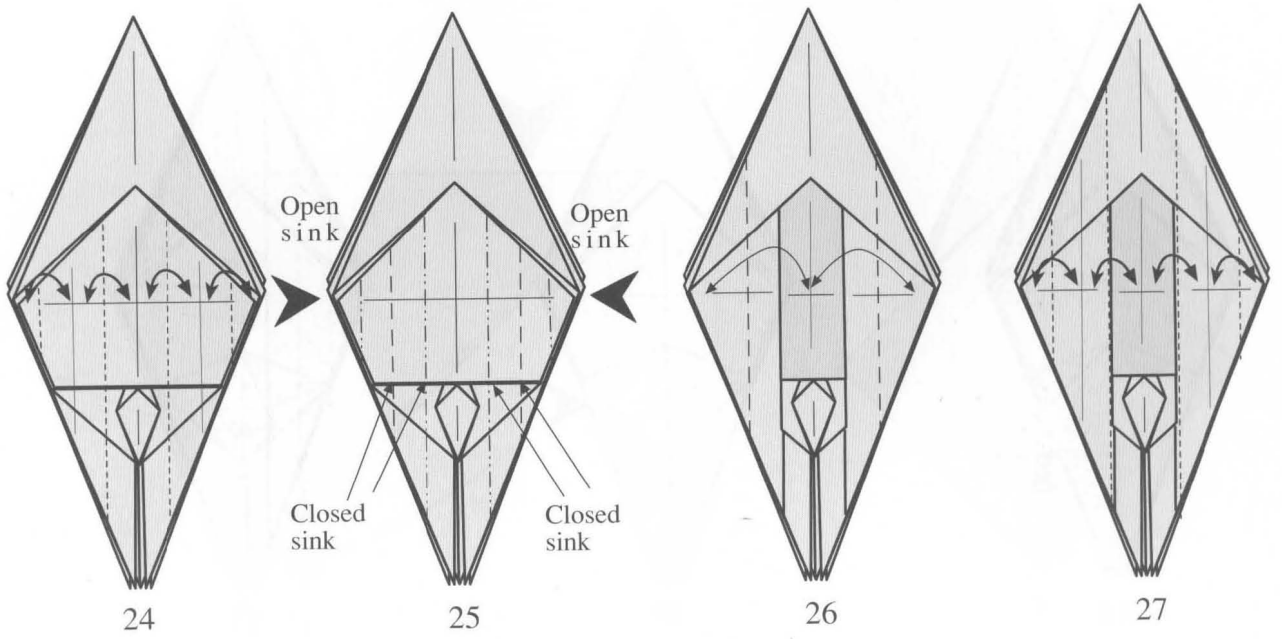

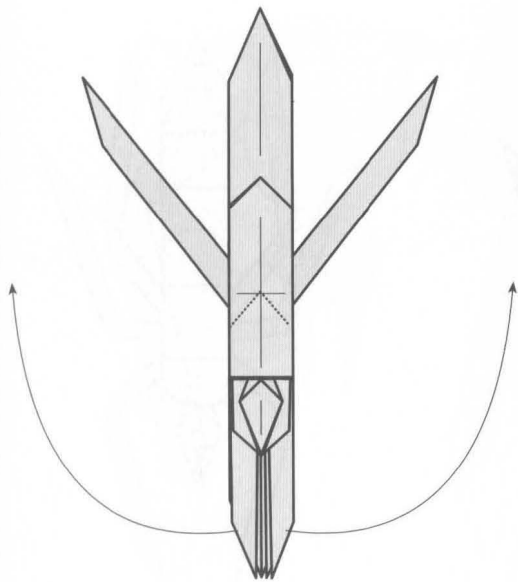

36

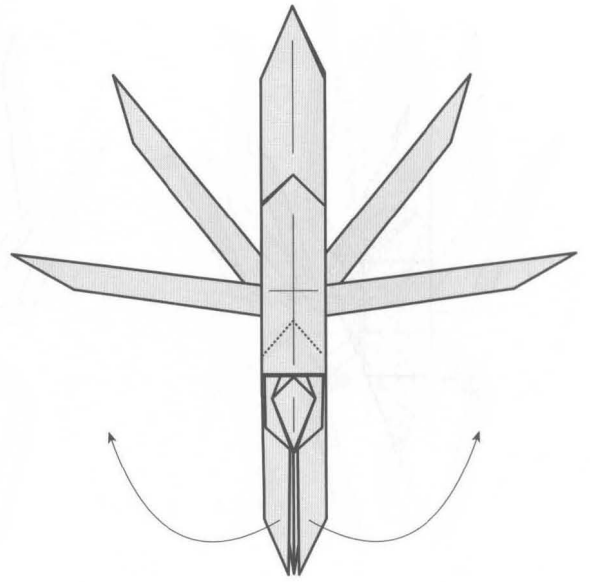

37

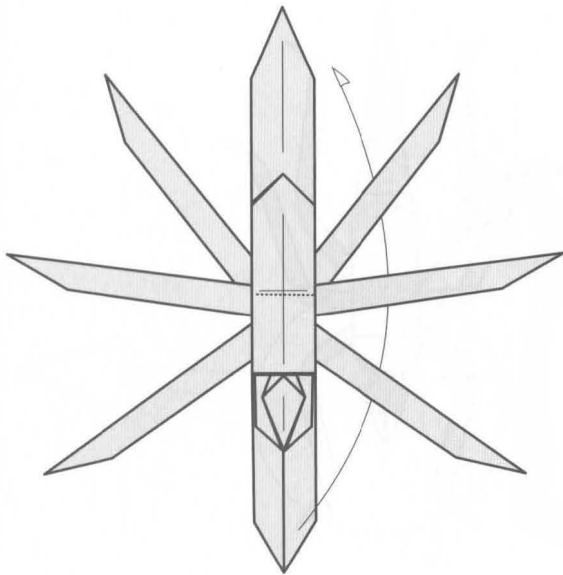

38

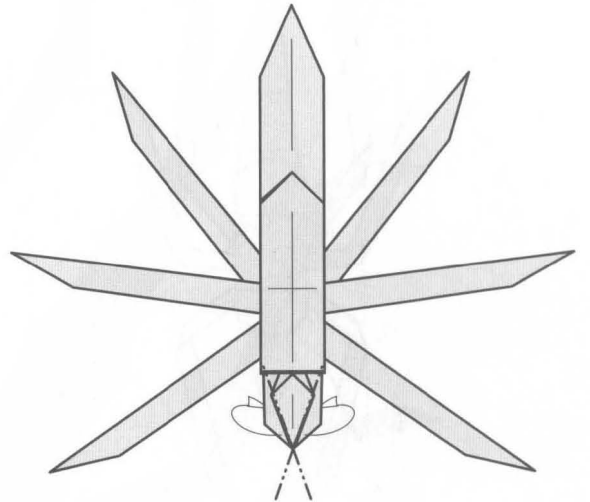

39

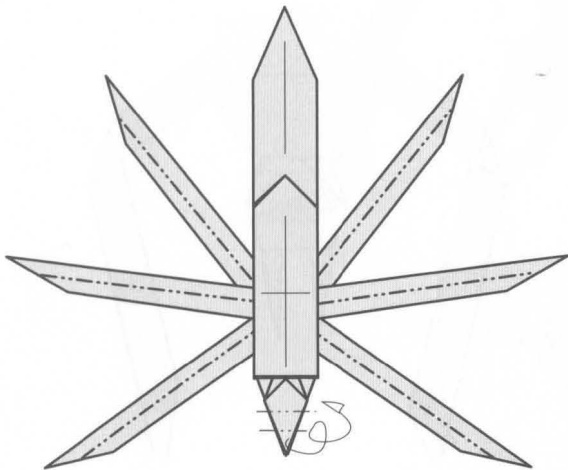

40

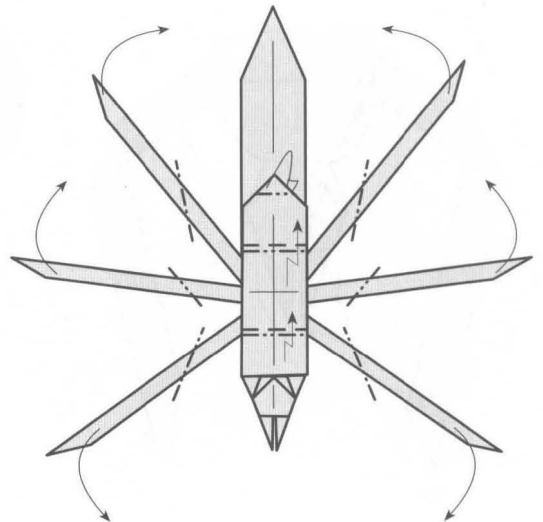

41

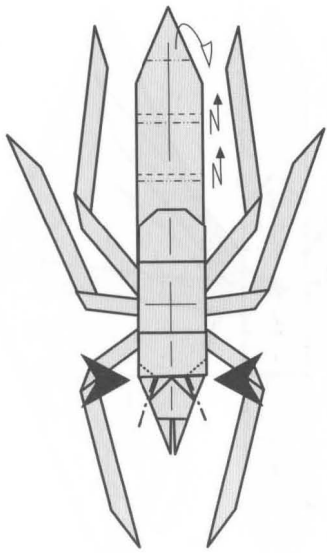

42

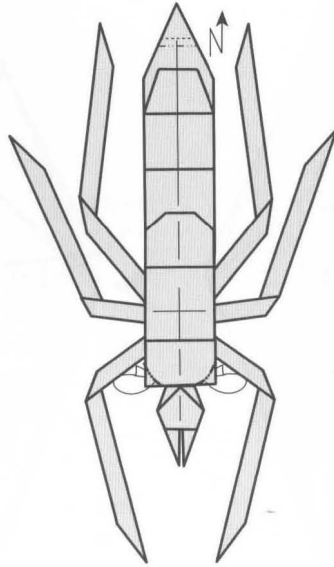

43

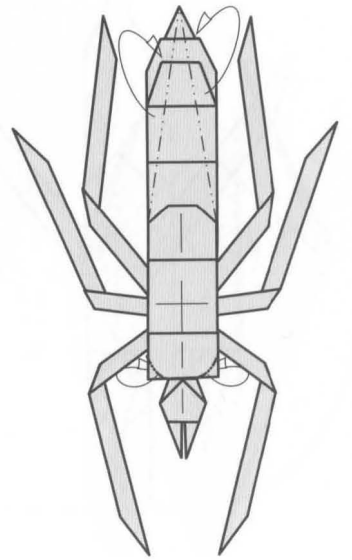

44

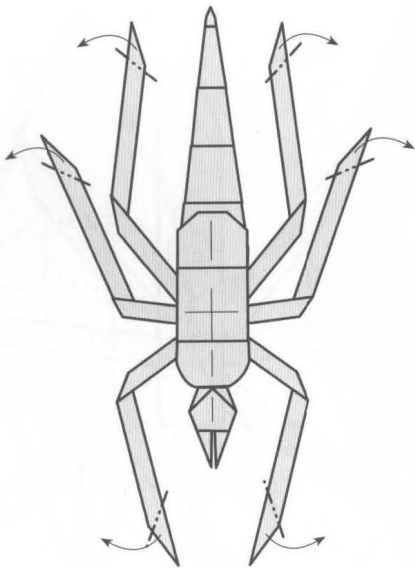

45

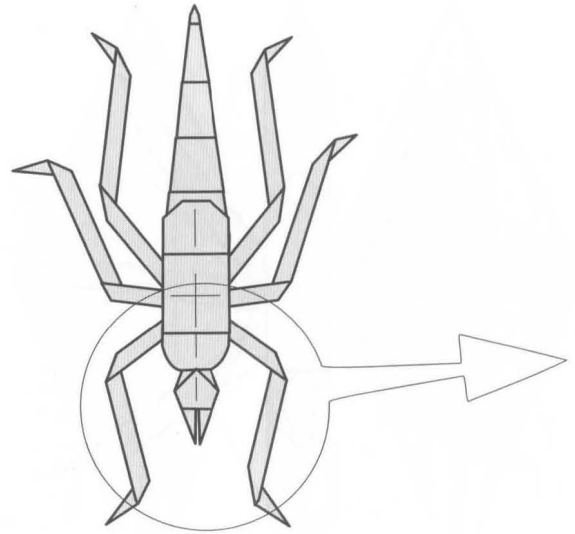

46

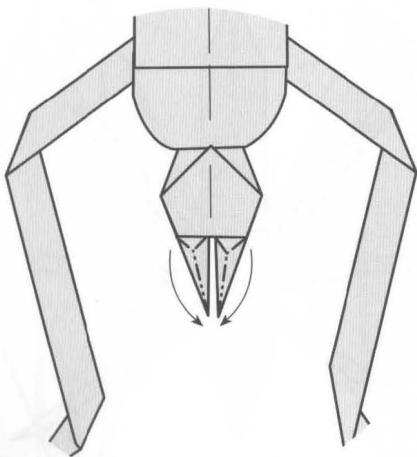

47

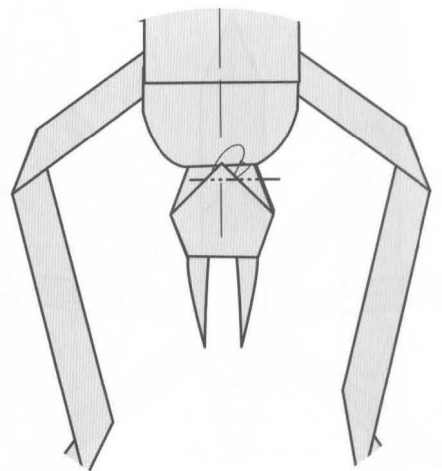

48

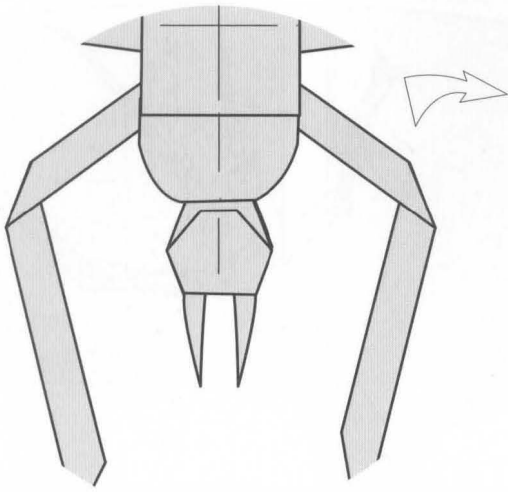

49

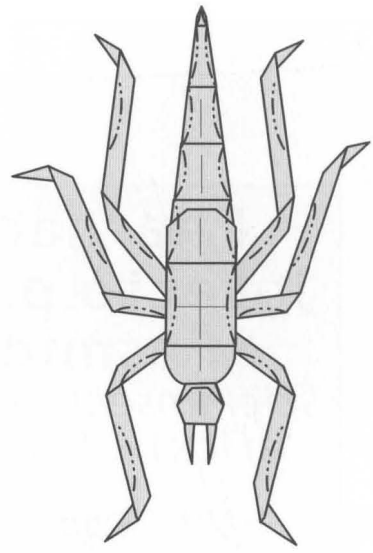

50

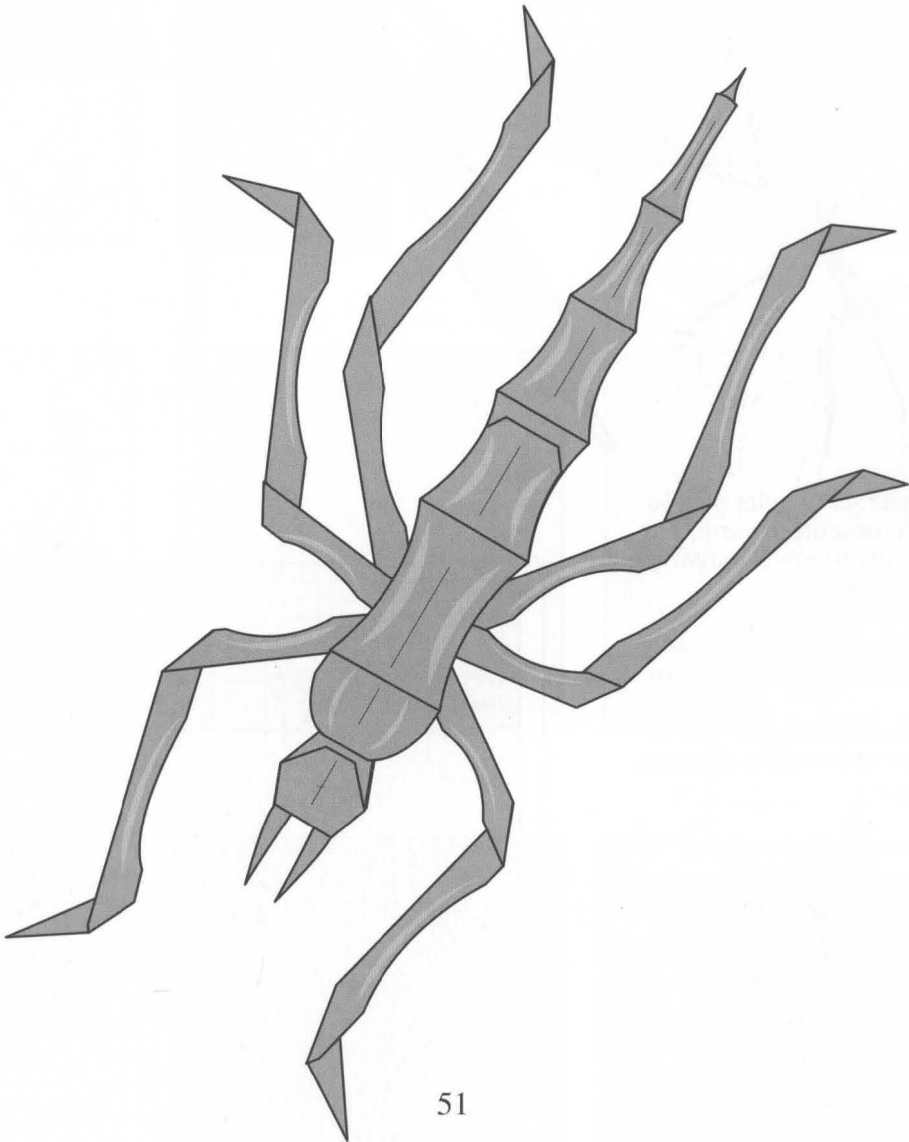

51



El papel puede ser de color marrón claro, marrón oscuro o verde. Se recomienda 40x40 cm o mayor y menor de 30 gr/m².

An appropriate color for paper would be light-brown, dark-brown or green. It is recommended size of 40 x40 cm or bigger and weight slighther than 30 gr/m².

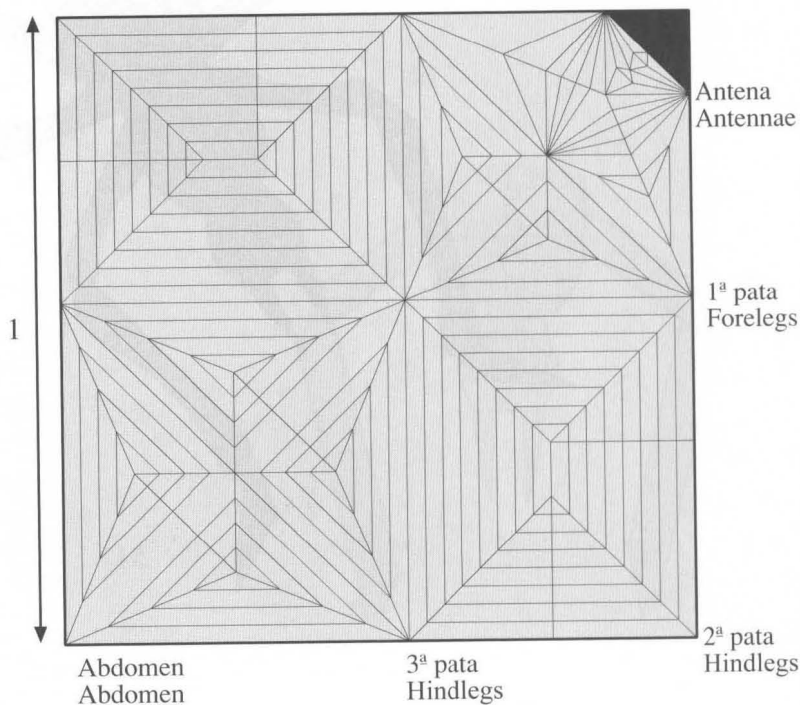
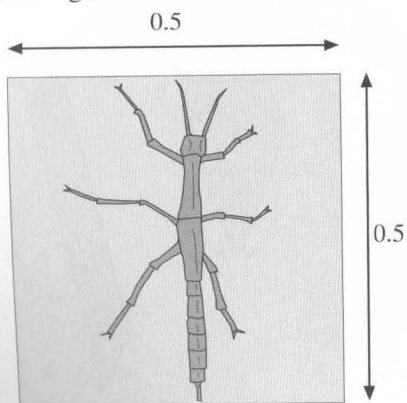

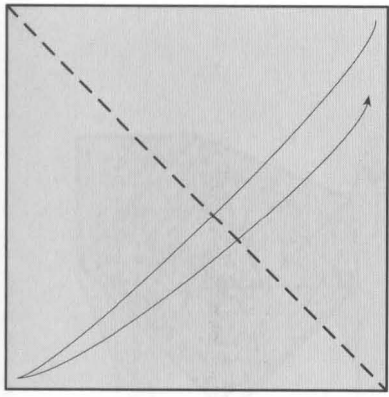

1

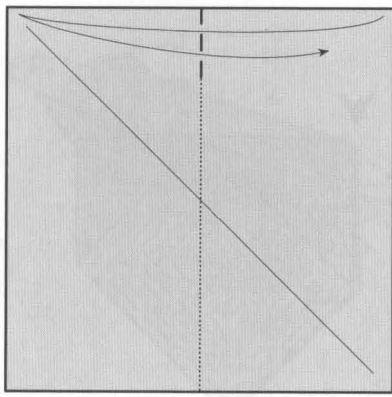

2

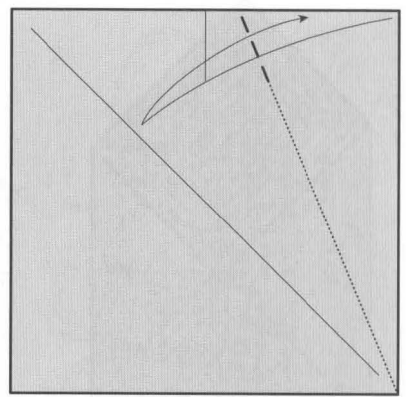

3

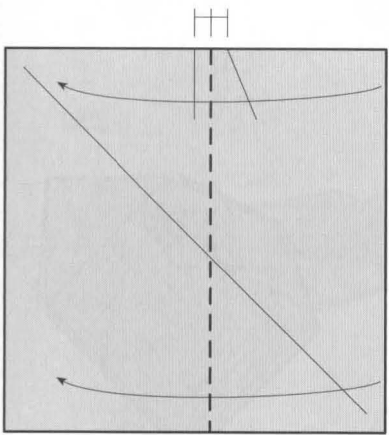

4

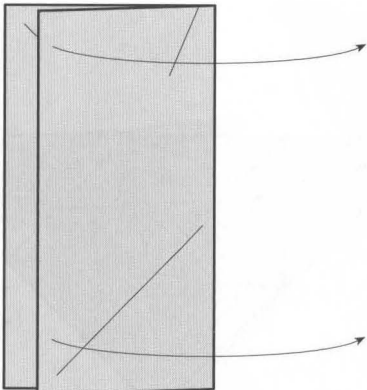

5

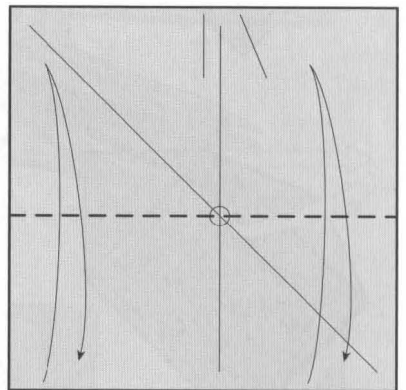

6

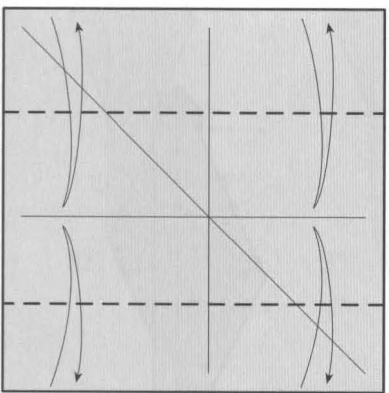

7

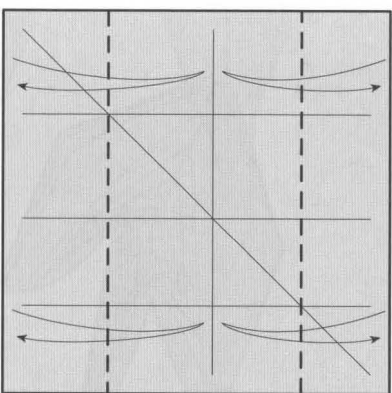

8

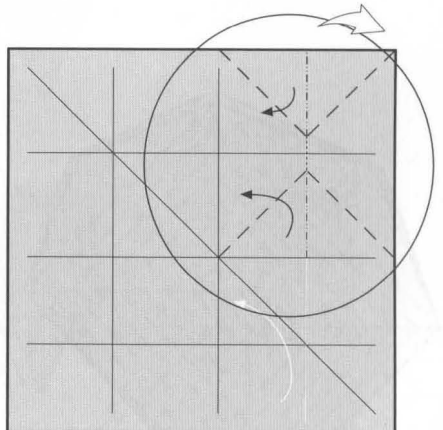

9

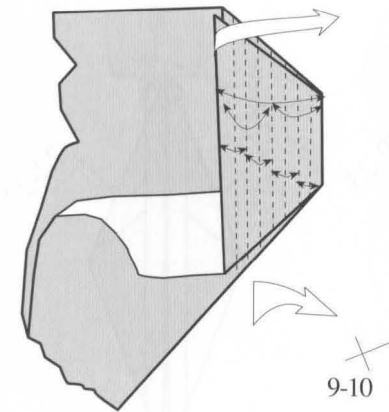

10

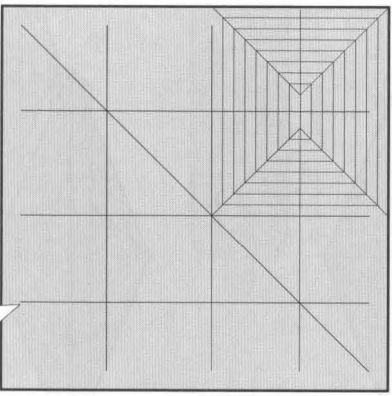

11

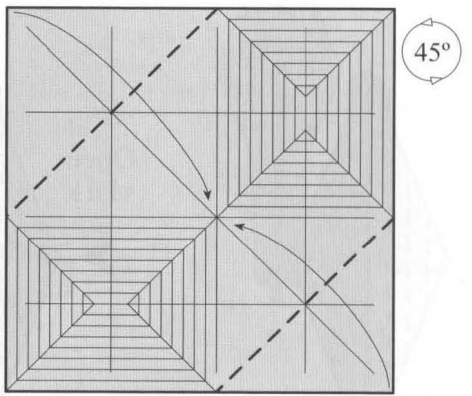

12

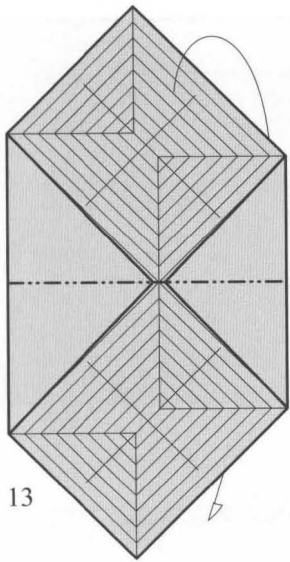

13

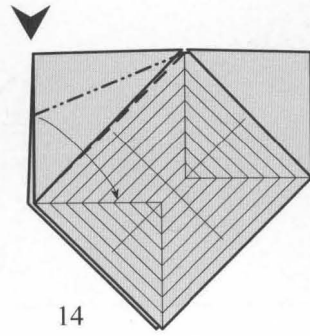

14

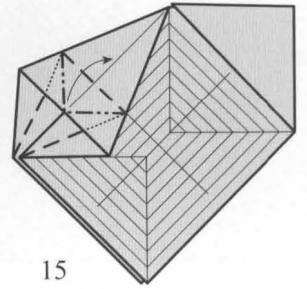

15

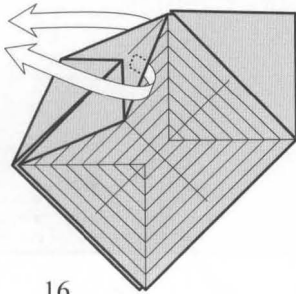

16

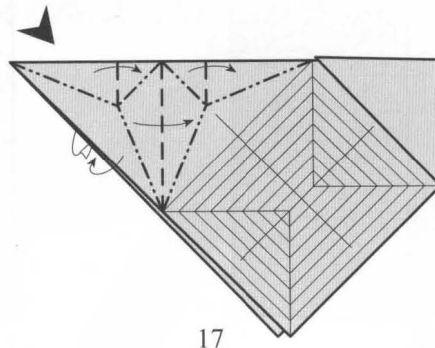

17

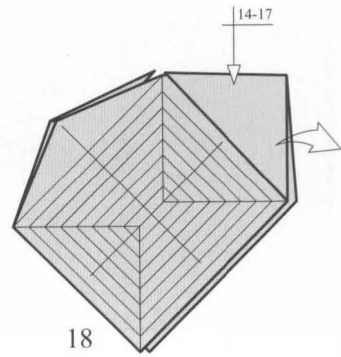

18

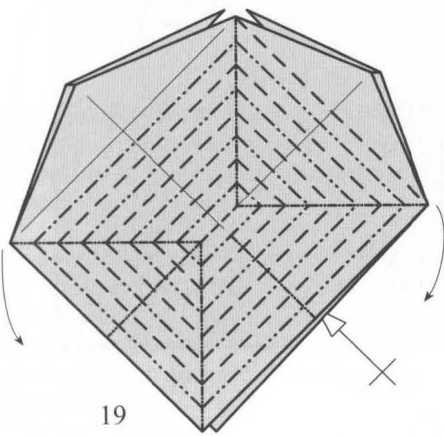

19

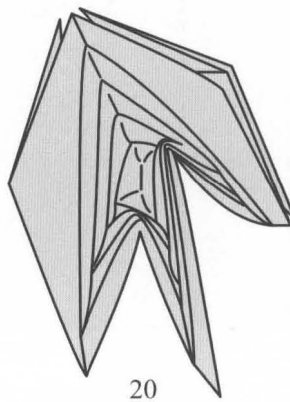

20

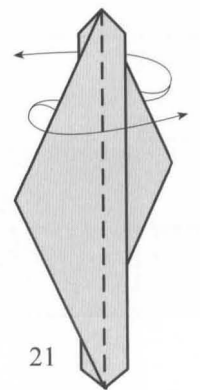

21

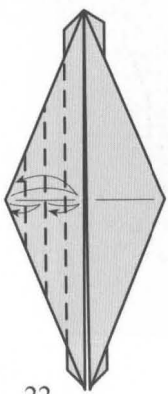

22

Open
sink

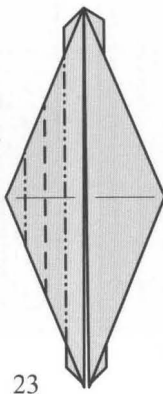

23

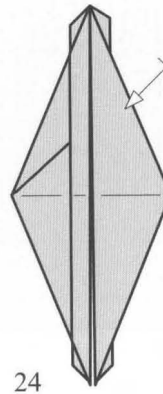

24

22-23

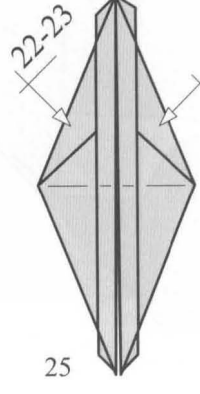

25

22-23

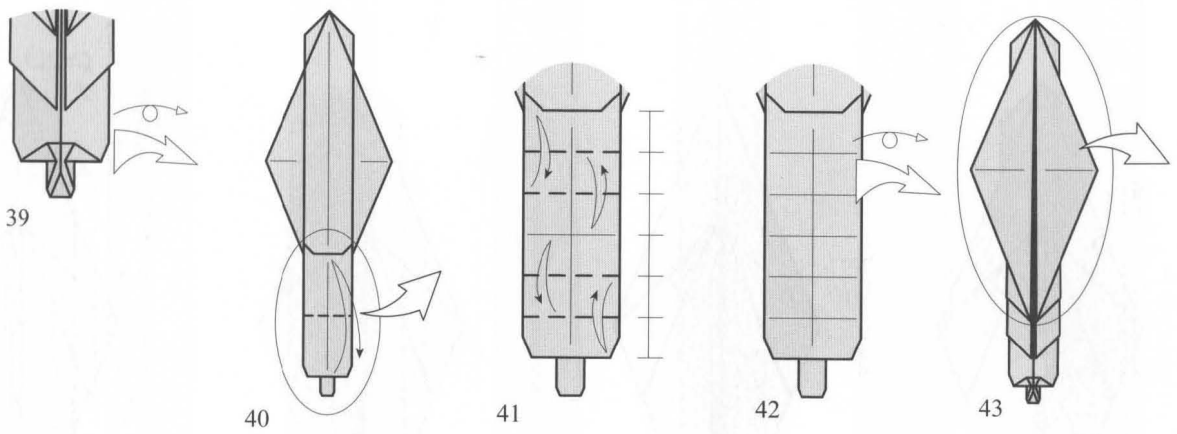
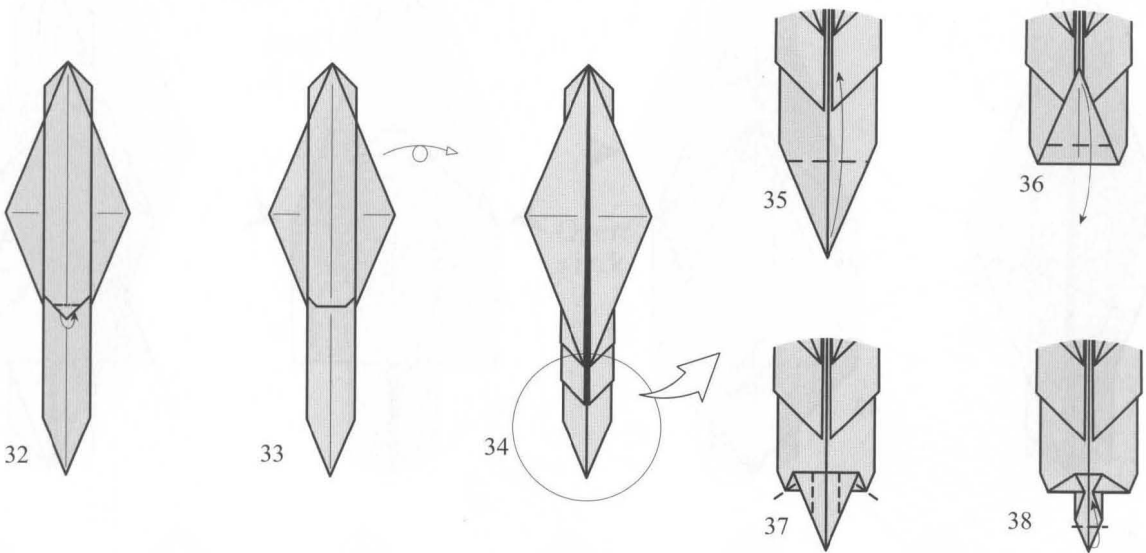
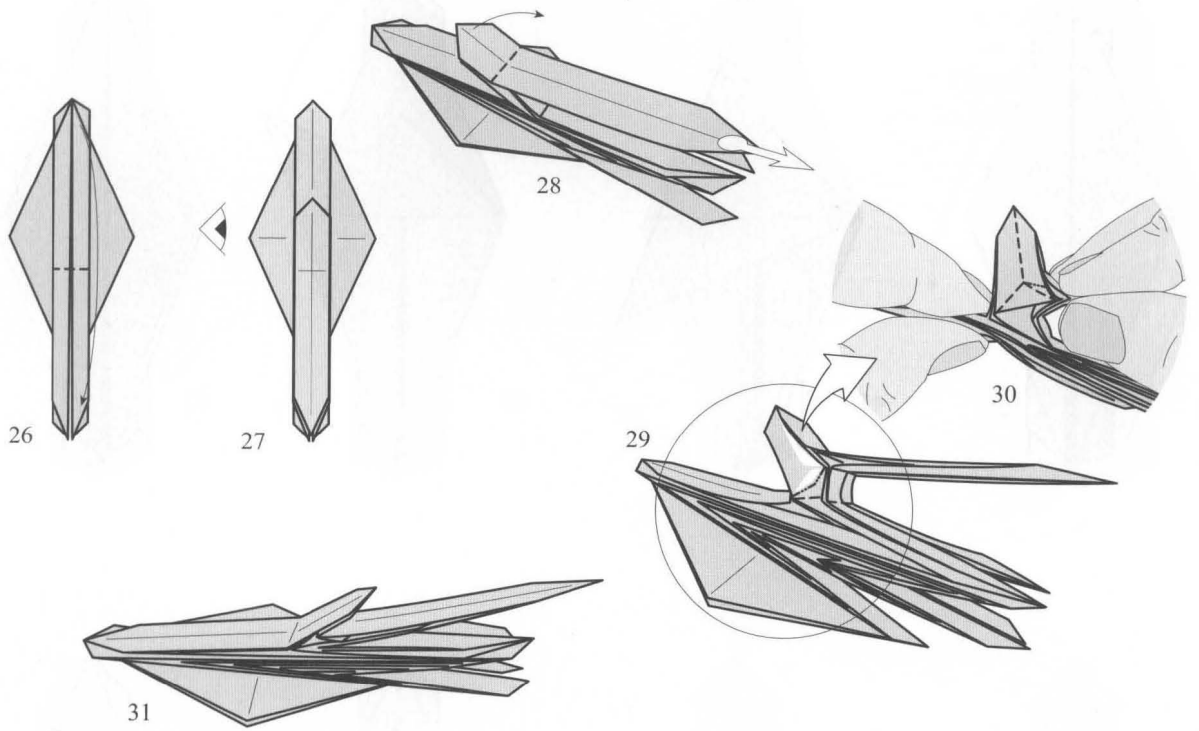

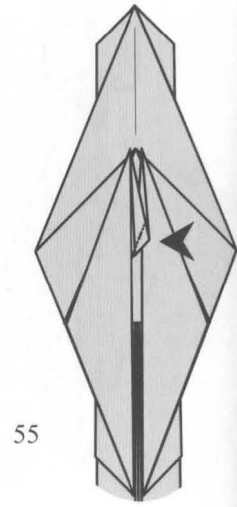
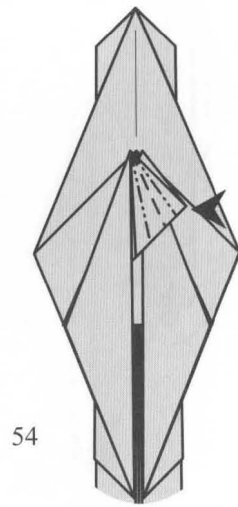
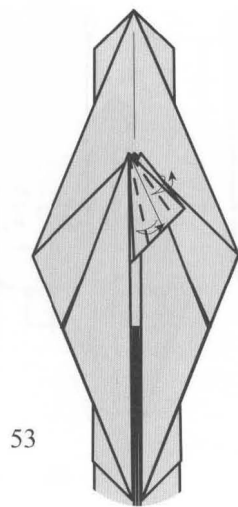
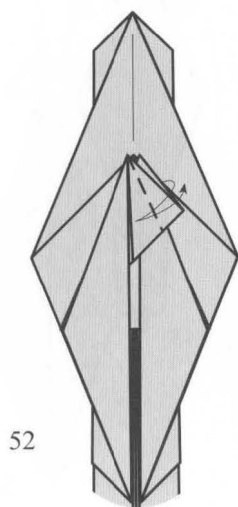
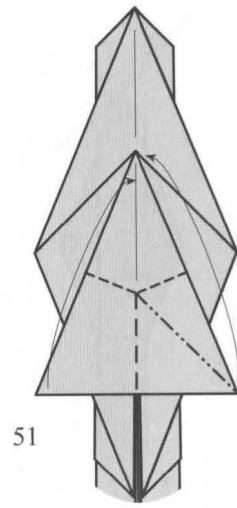
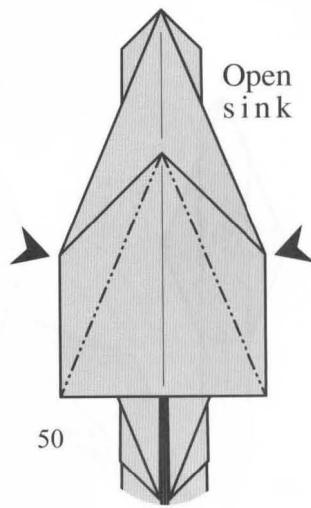
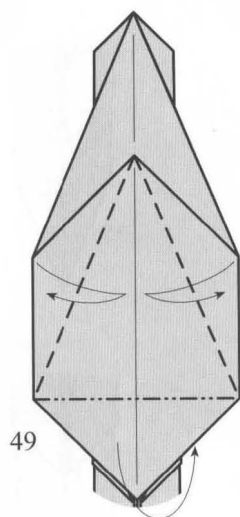
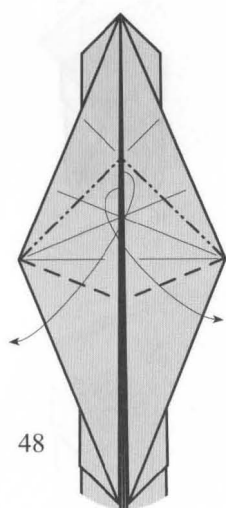
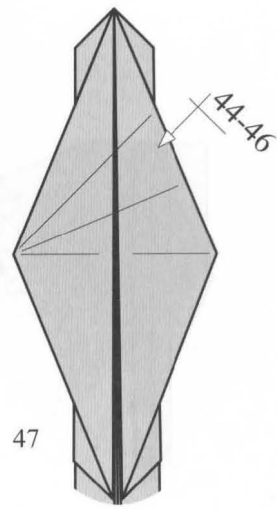
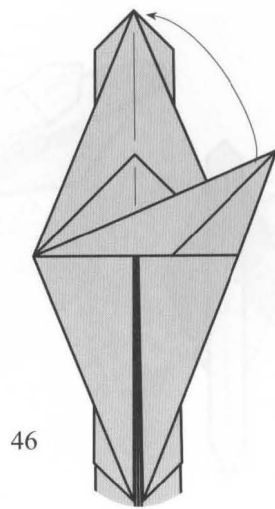
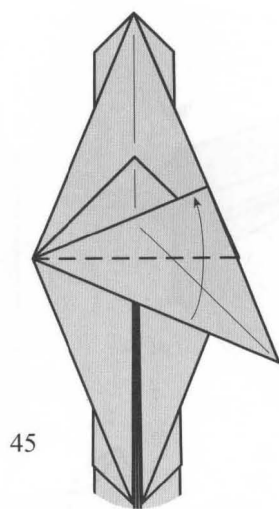
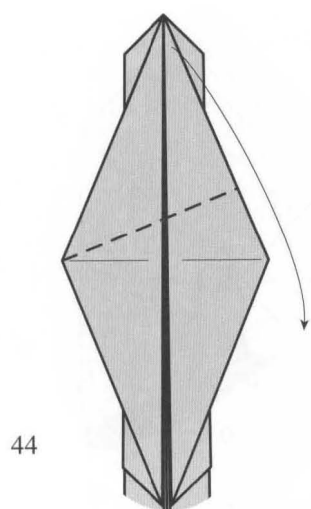

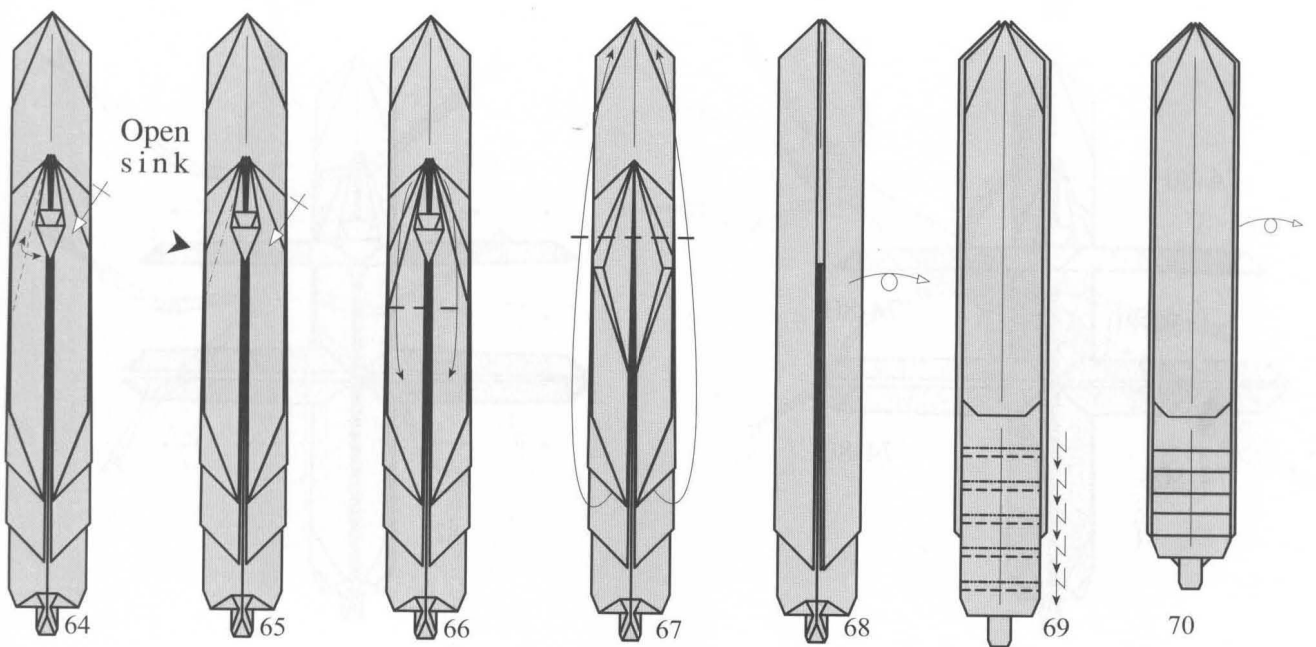
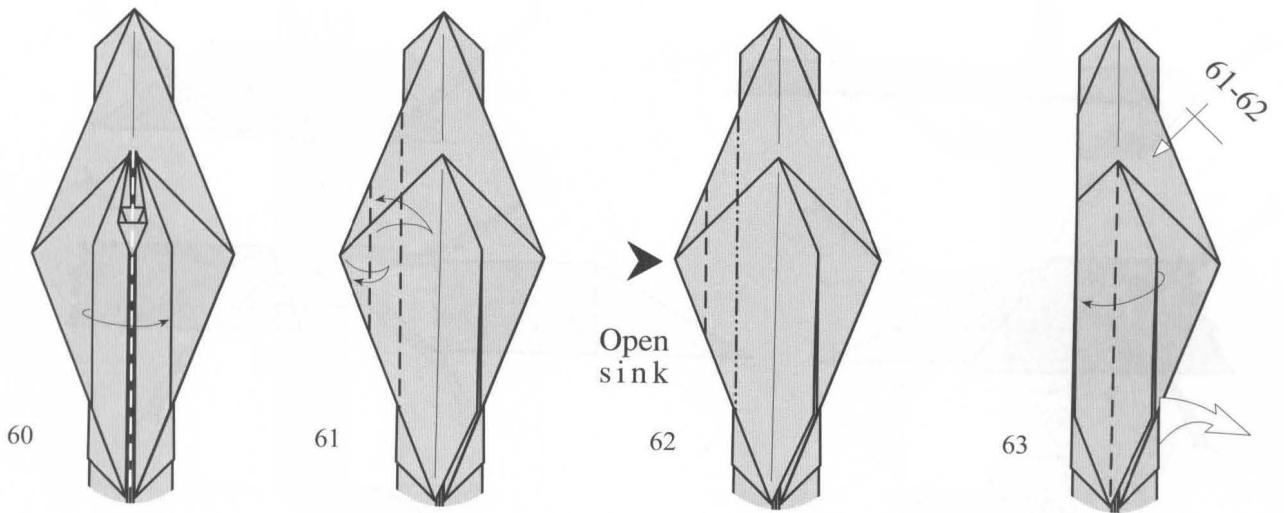
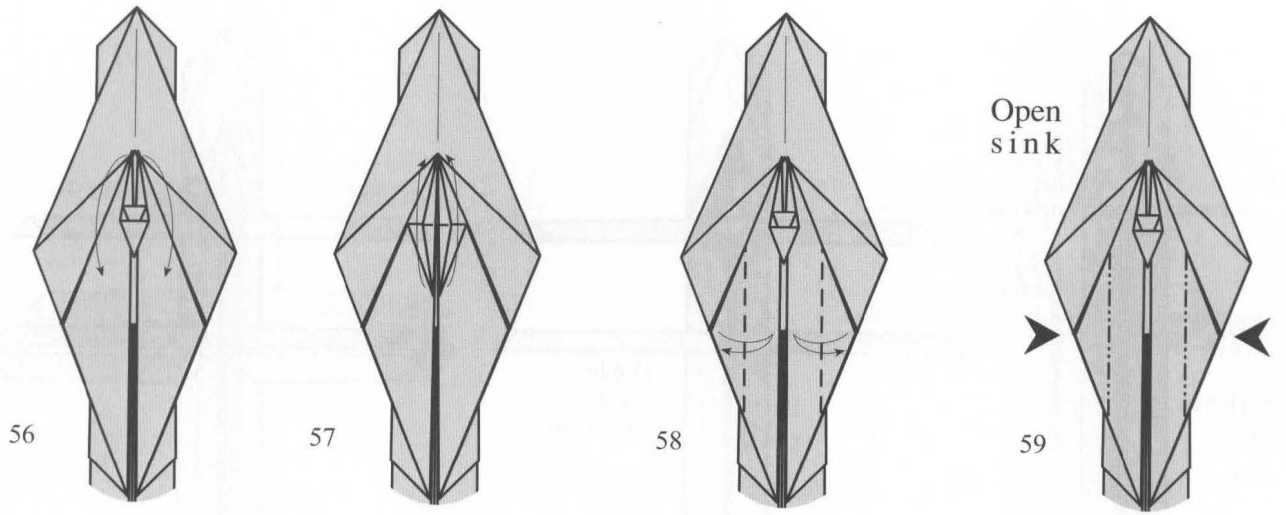

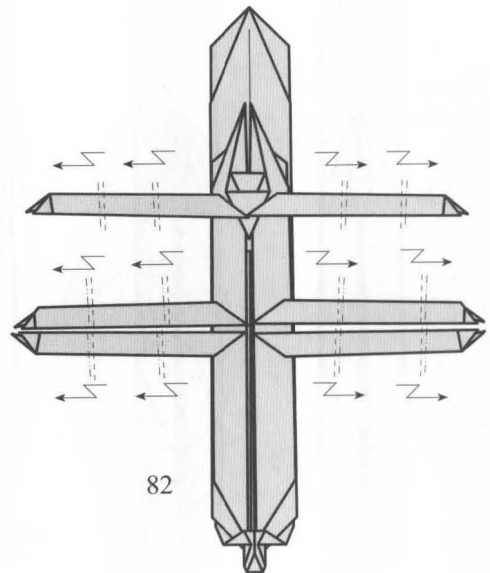
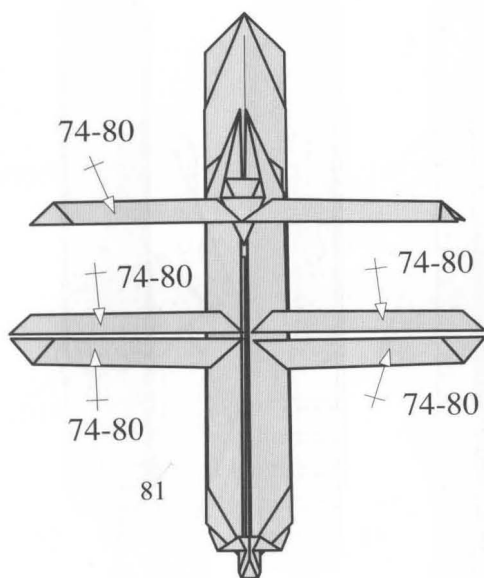
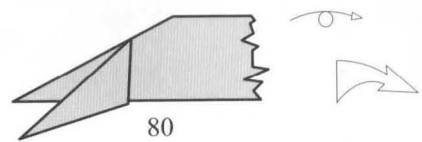
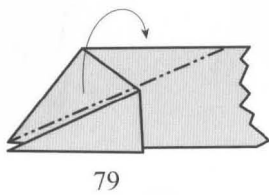
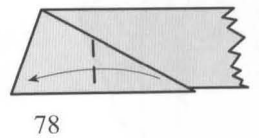
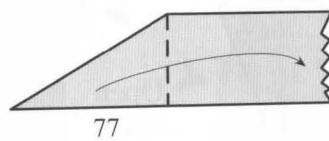
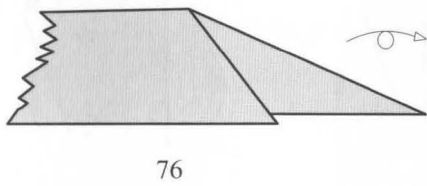
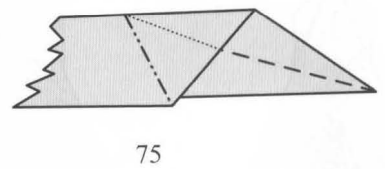
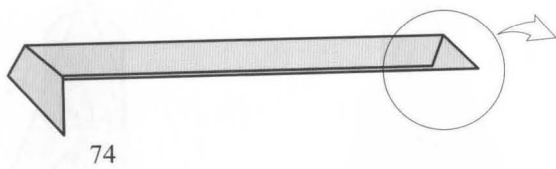
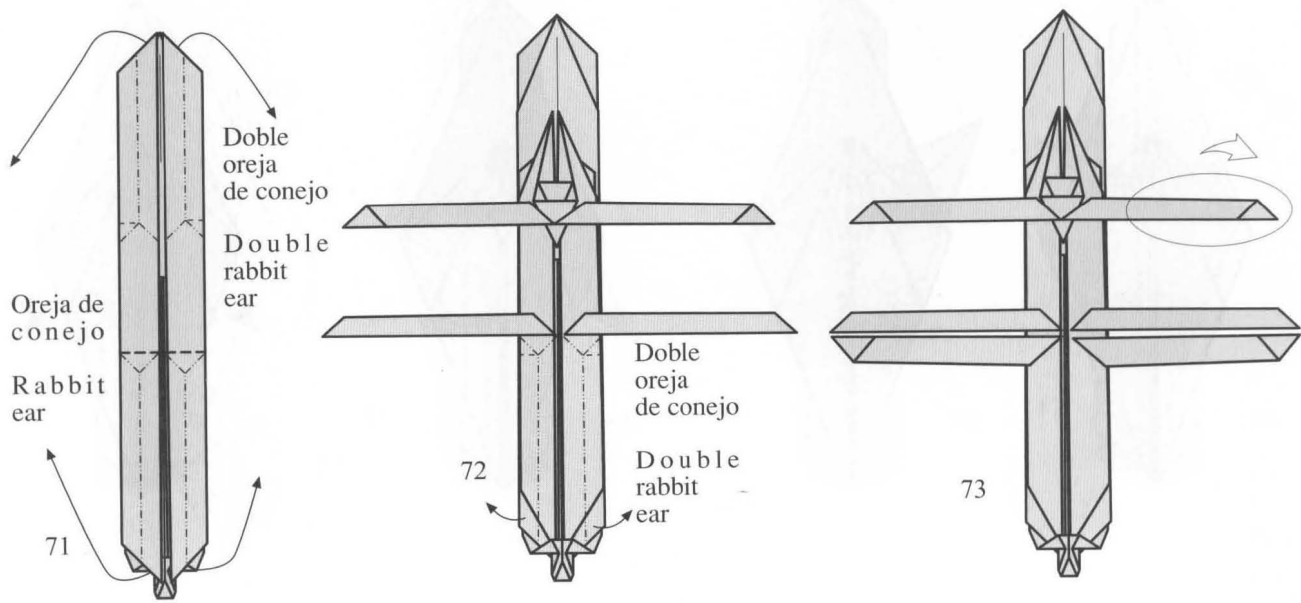

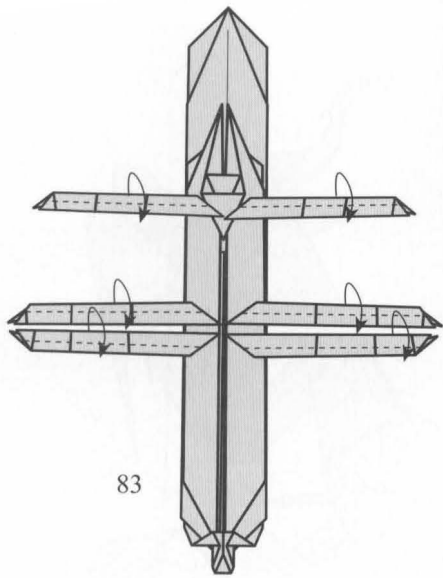

83

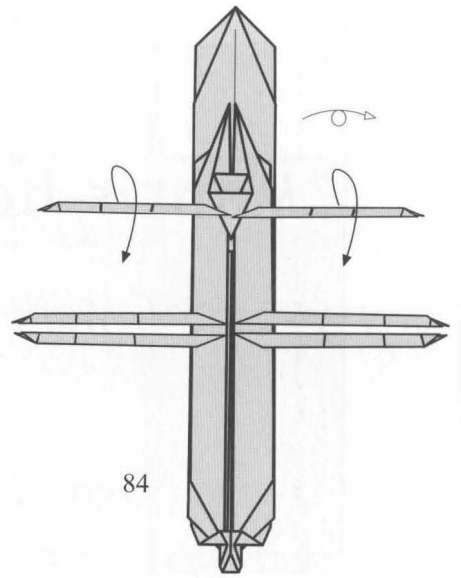

84

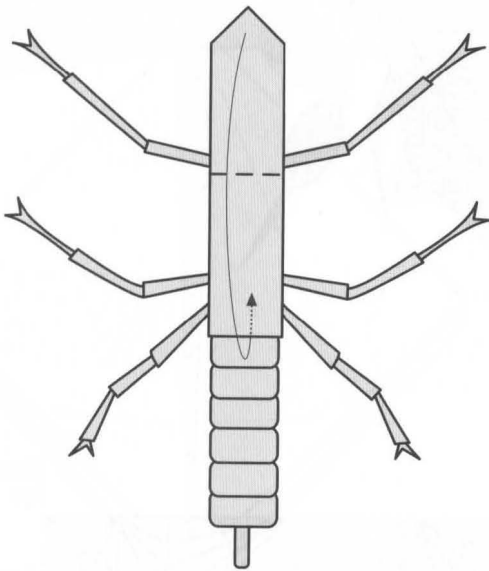

85

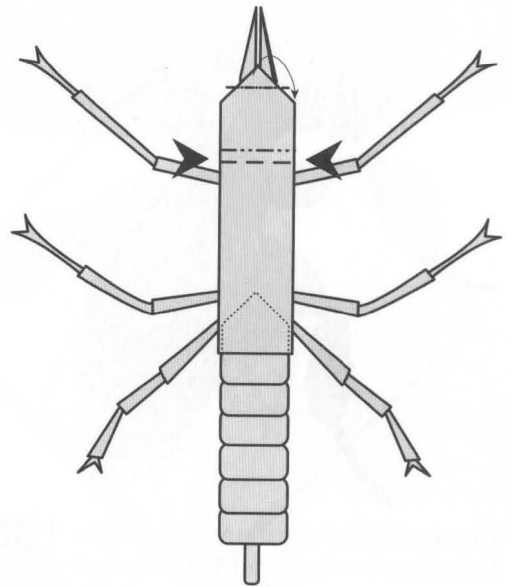

86

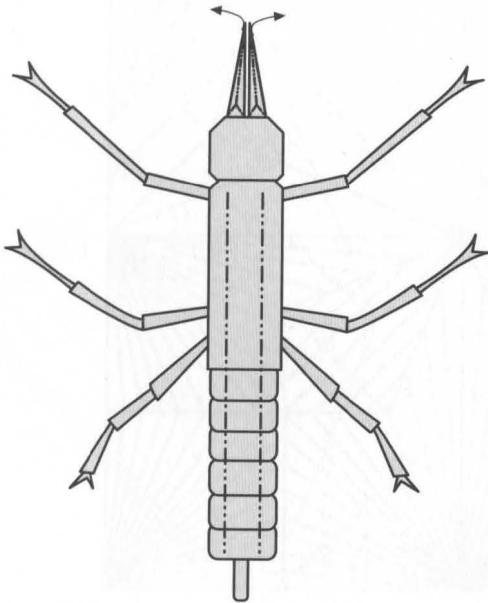

87

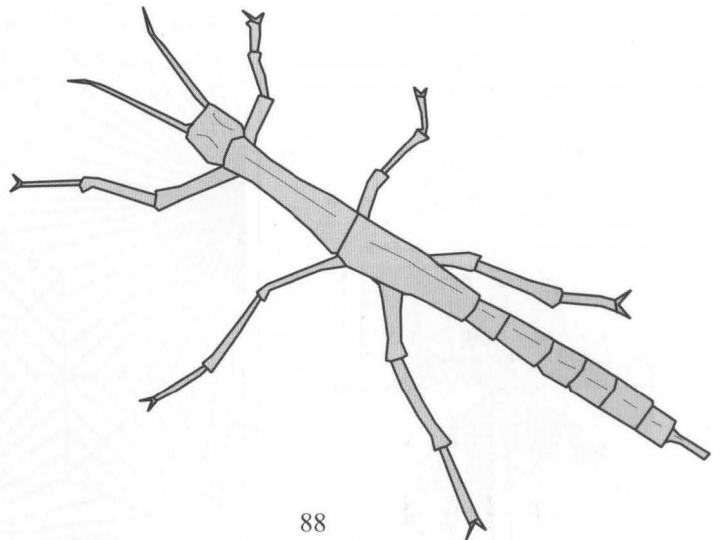

88

Mantis hoja

Leaf Mantis

© M. Sirgo - 2003

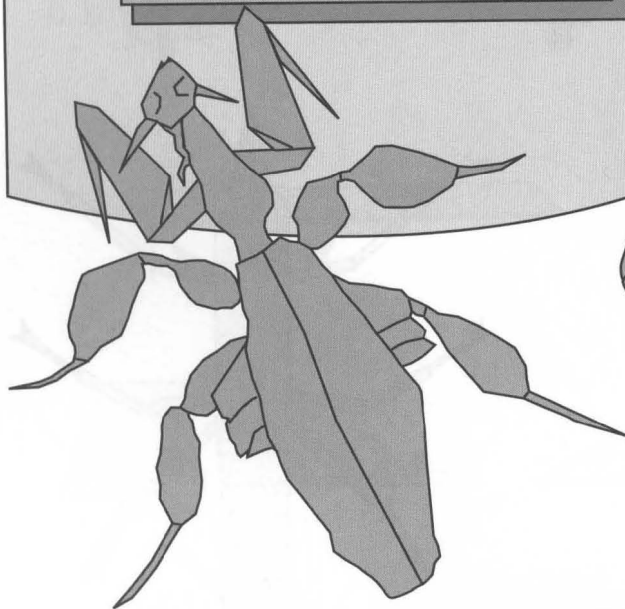

El papel debe ser marrón o verde. Se recomienda papel fino, menor de 40 gramos, metalizado, doble seda o del tipo *sandwich* y de dimensión 25x25 cm o mayor.

The paper should be brown or green. Fine paper is recommended, smaller than 40 grams, metalized, double silk or of the type "Sandwich" and of dimension 25x25 cm or bigger.

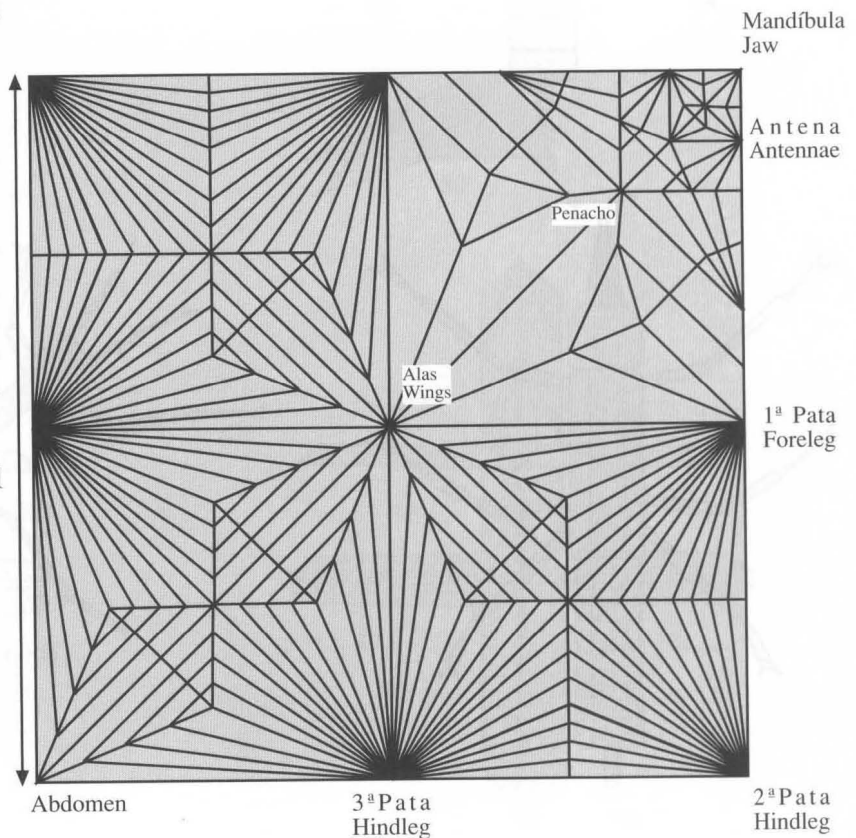
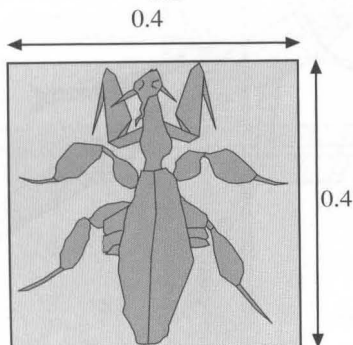

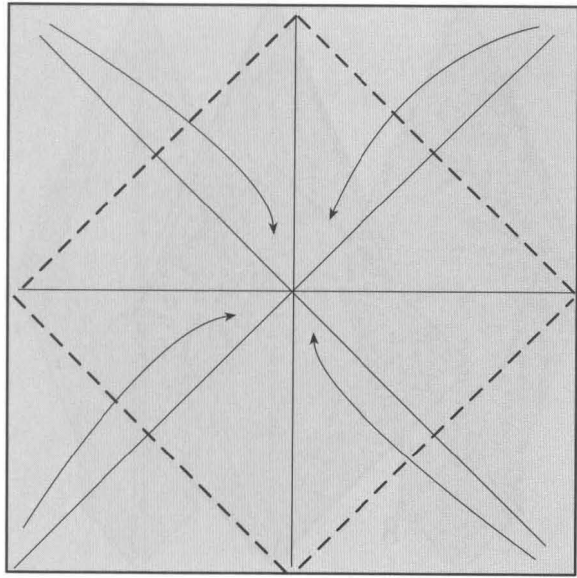

1

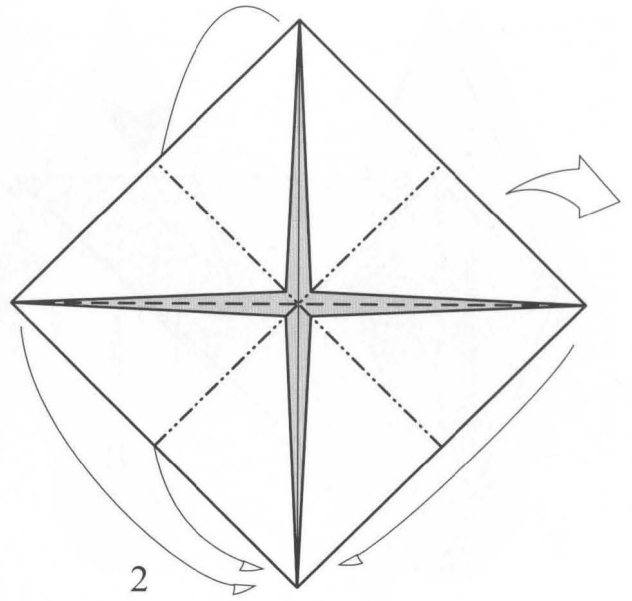

2

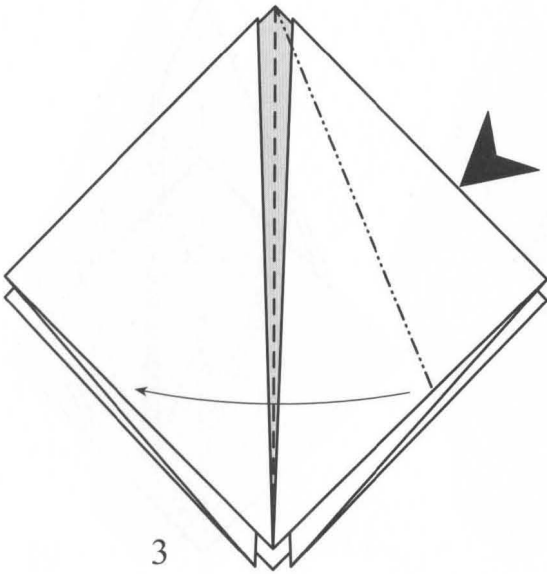

3

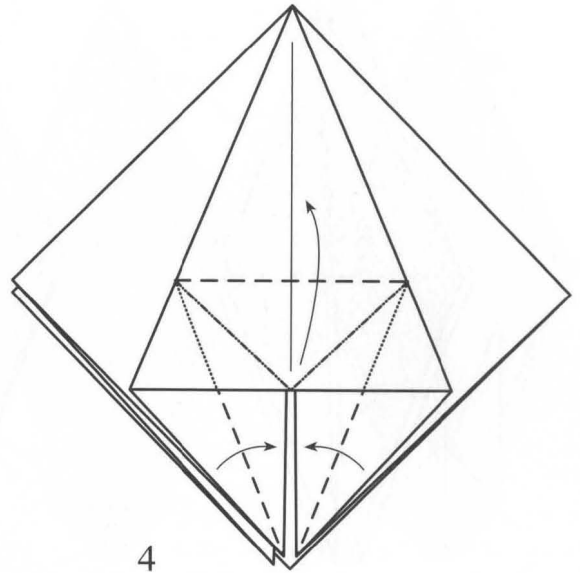

4

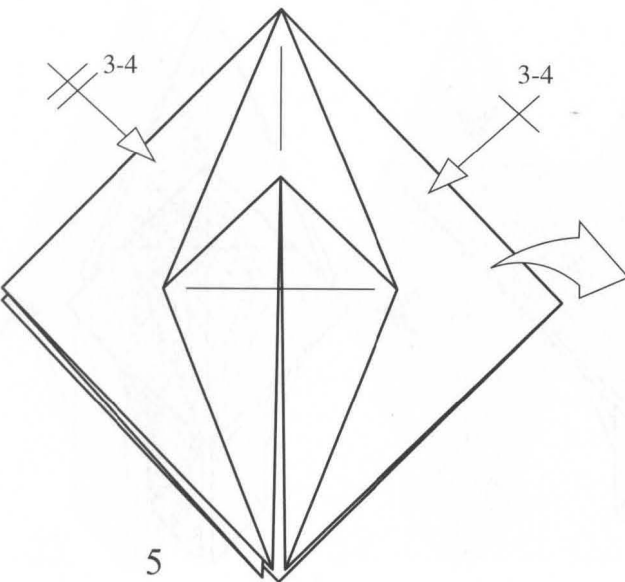

5

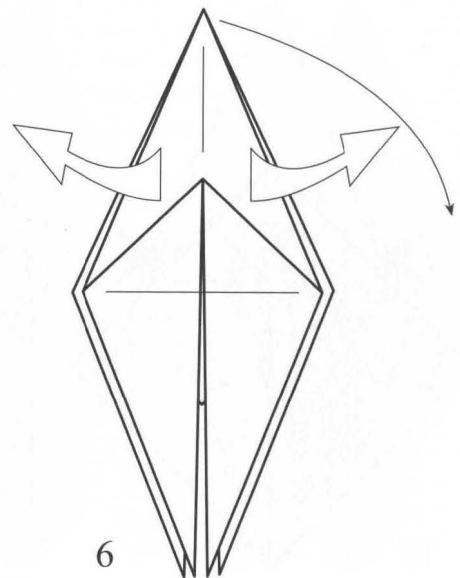

6

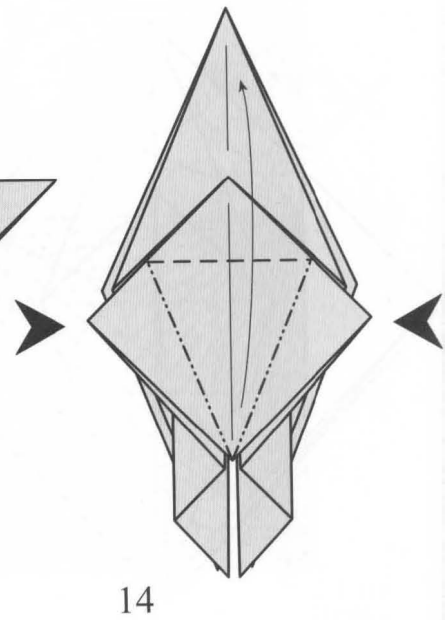
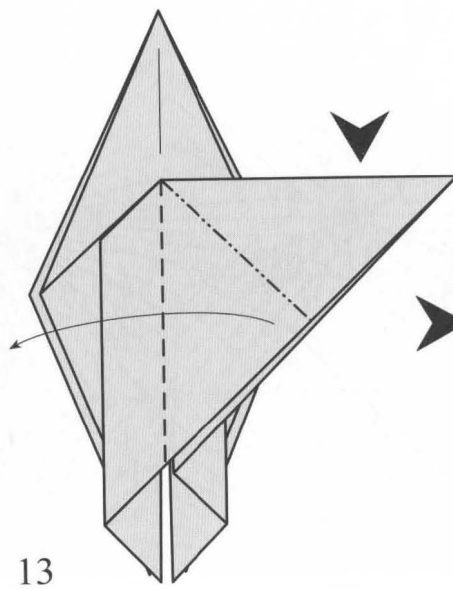
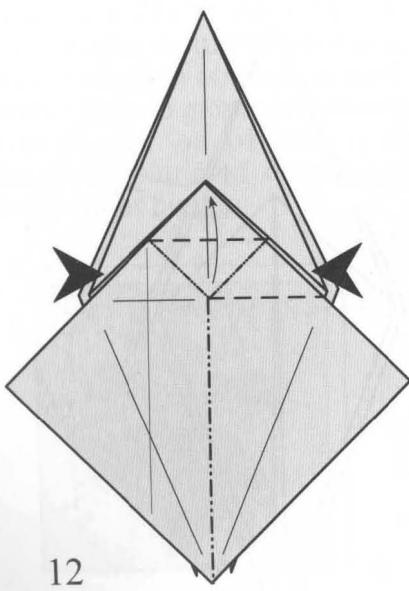
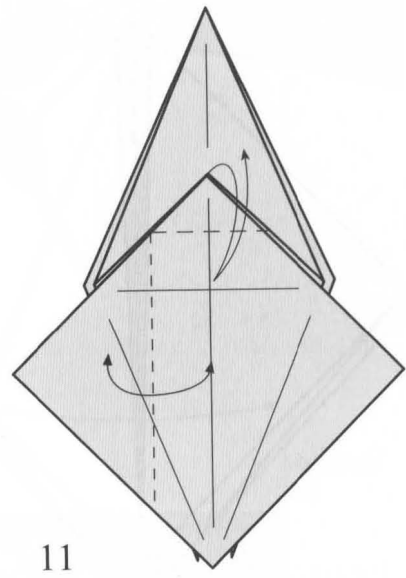
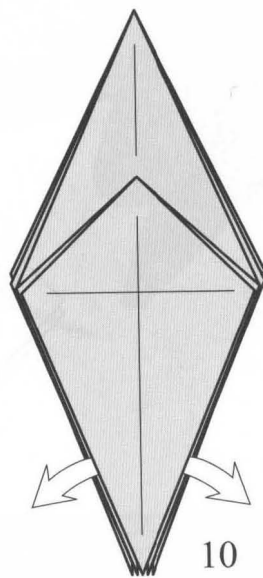
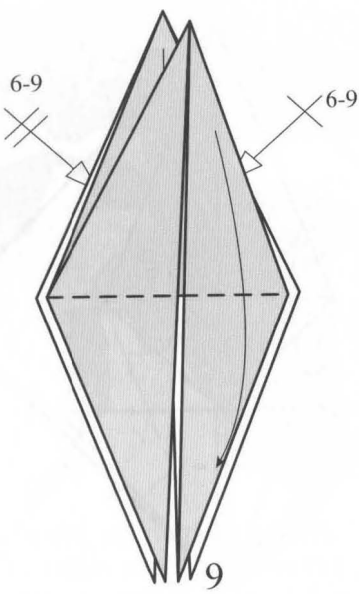
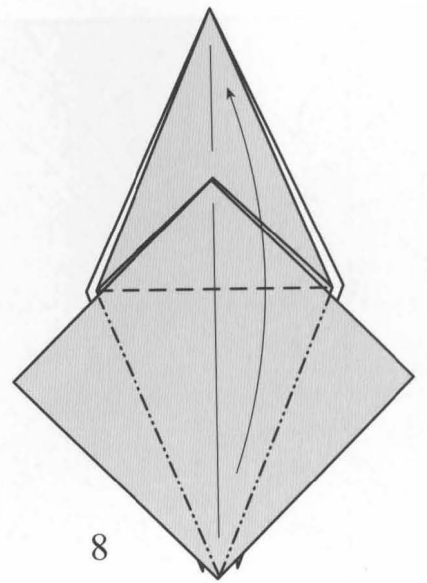
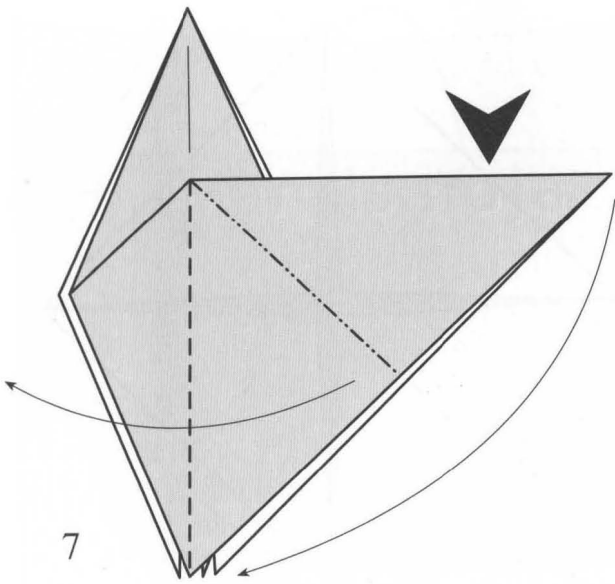

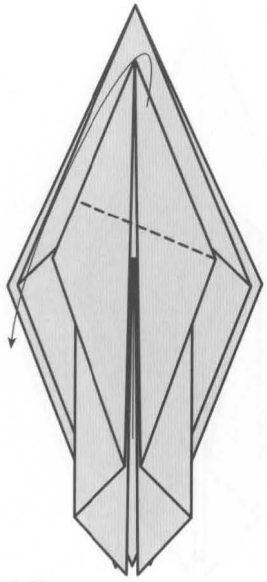

15

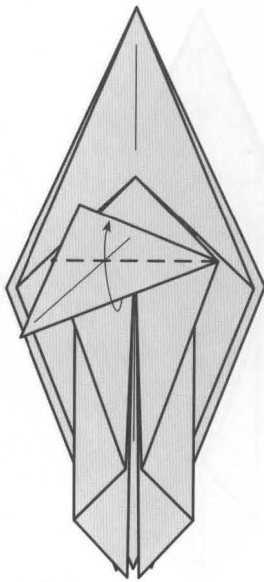

16

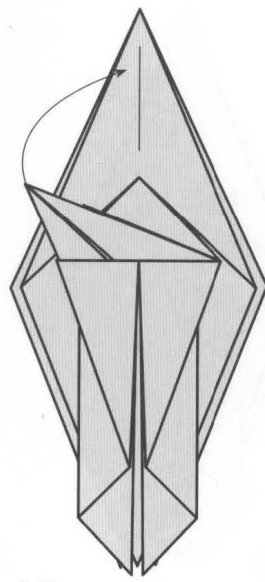

17

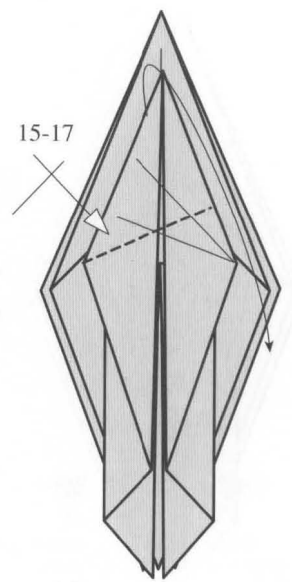

18

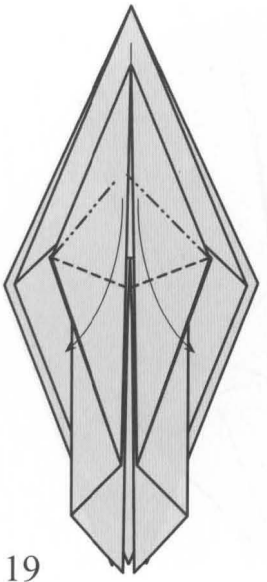

19

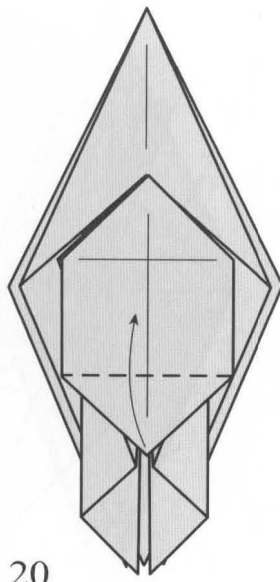

20

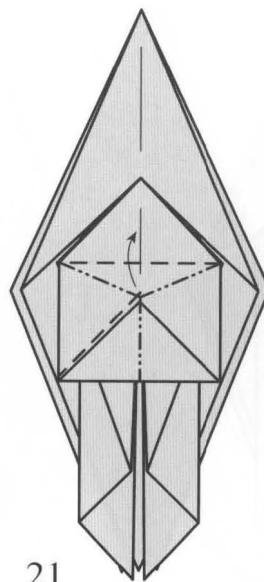

21

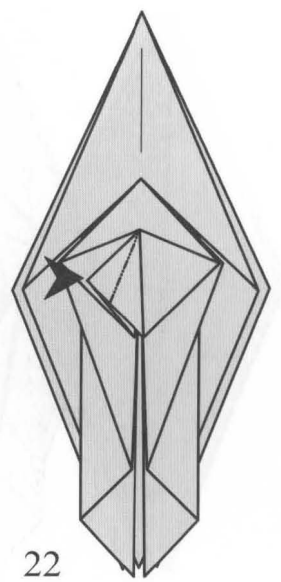

22

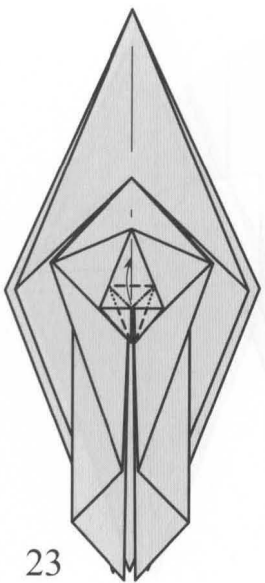

23

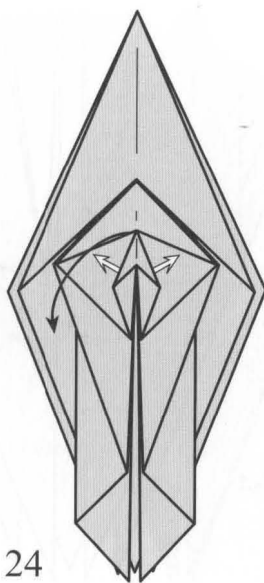

24

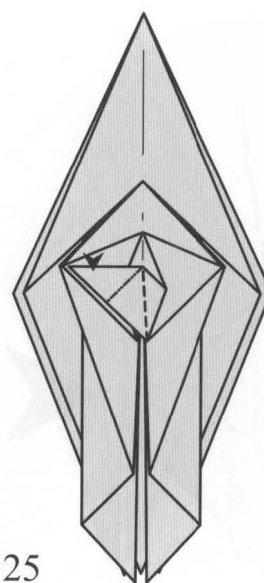

25

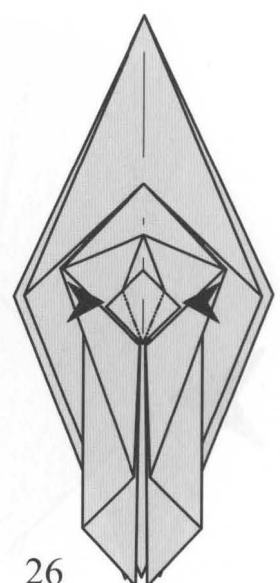

26

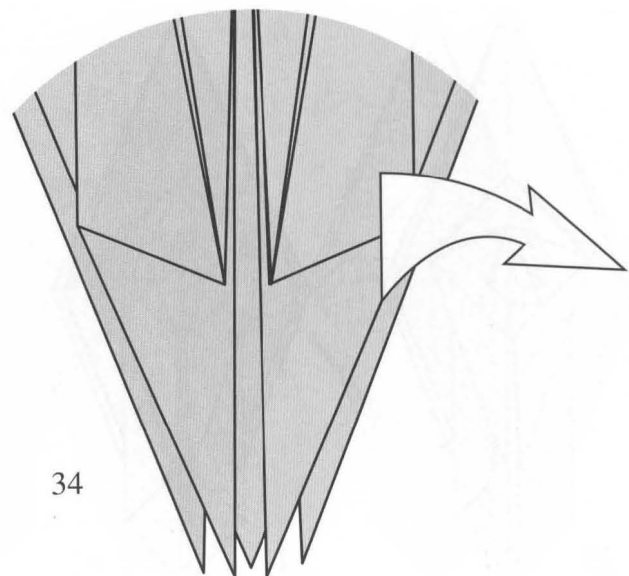
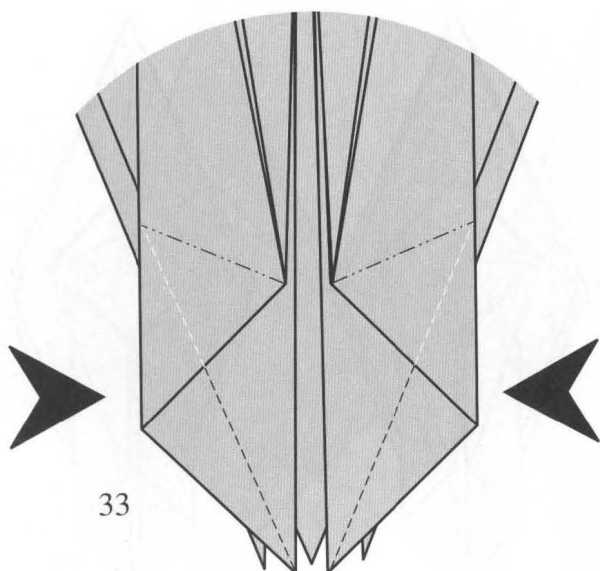
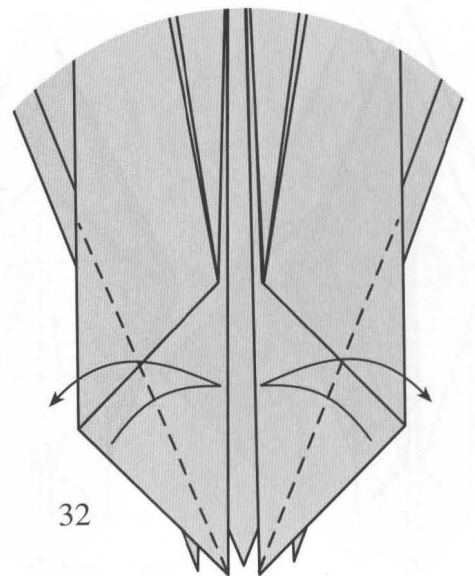
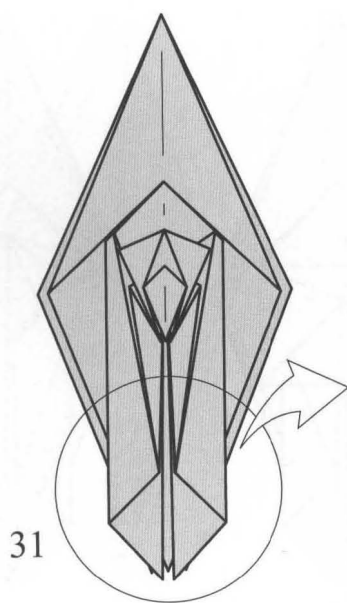
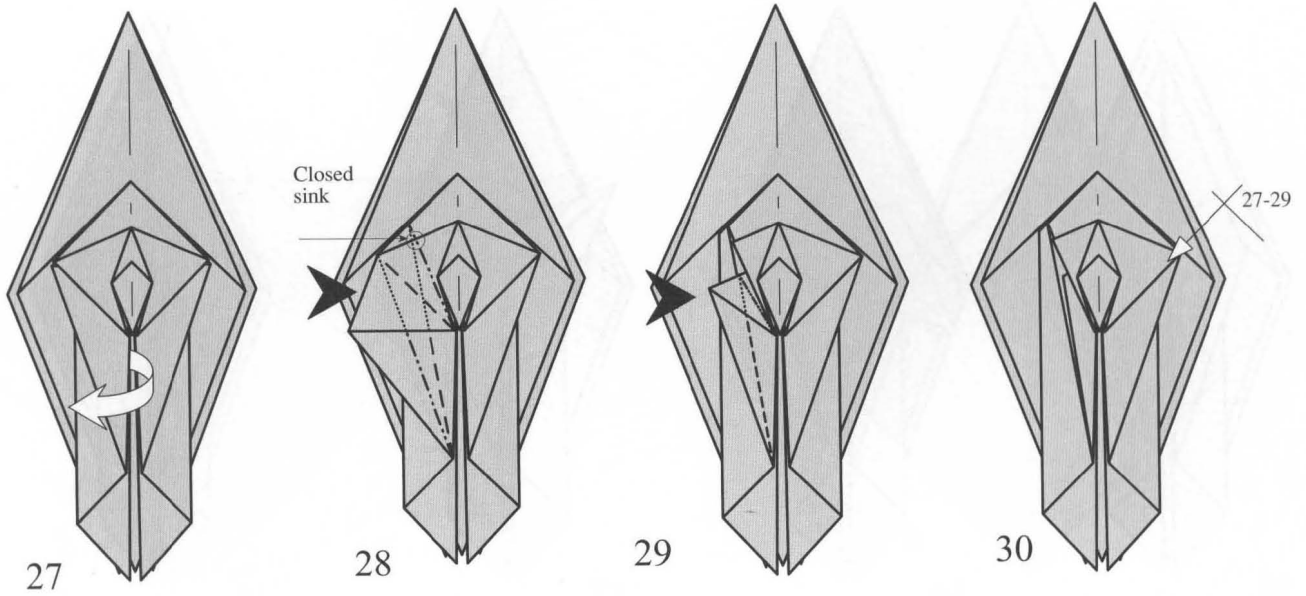

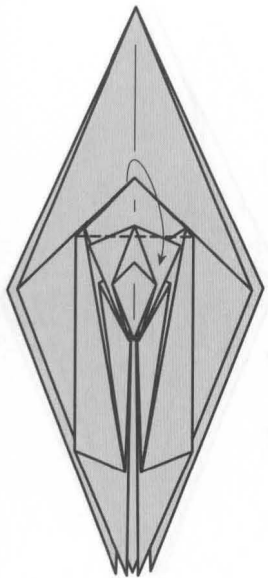

35

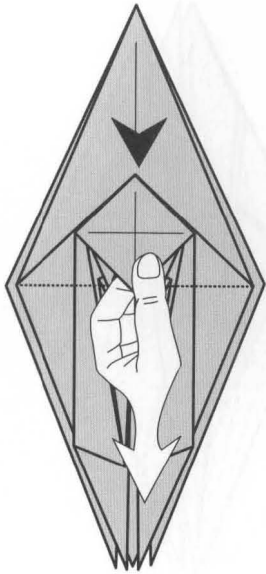

36

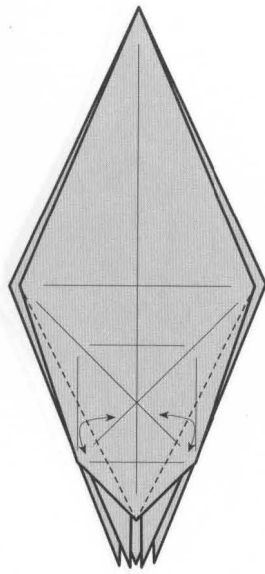

37

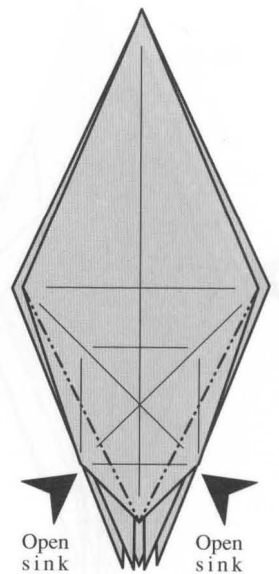

Open sink

Open sink

38

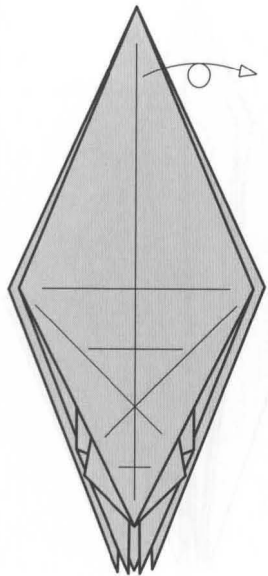

39

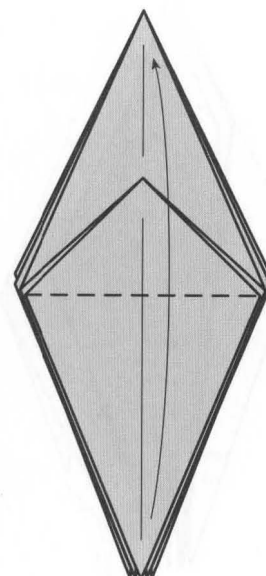

40

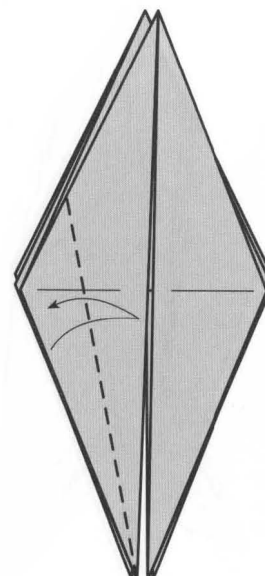

41

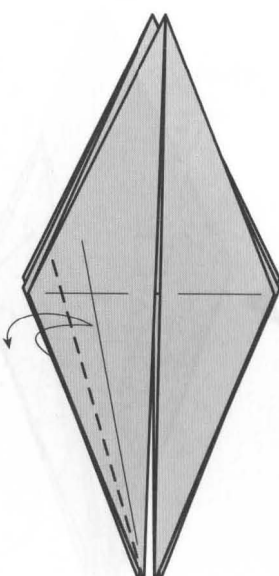

42

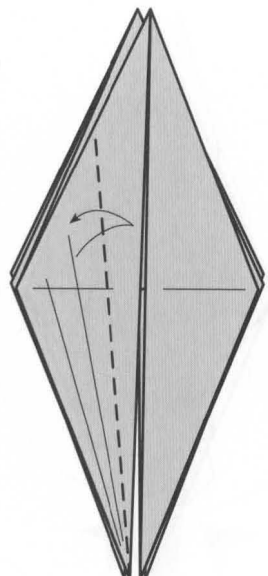

43

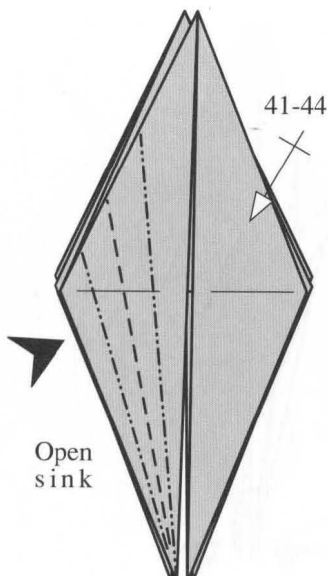

41-44

Open sink

44

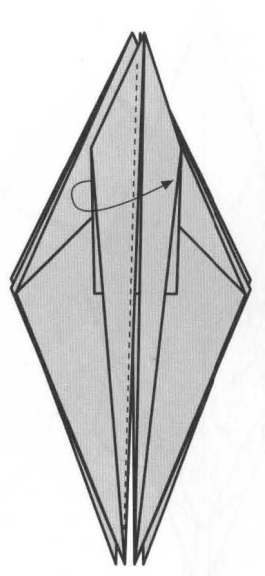

45

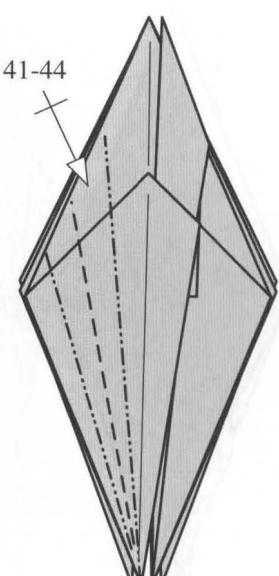

41-44

46

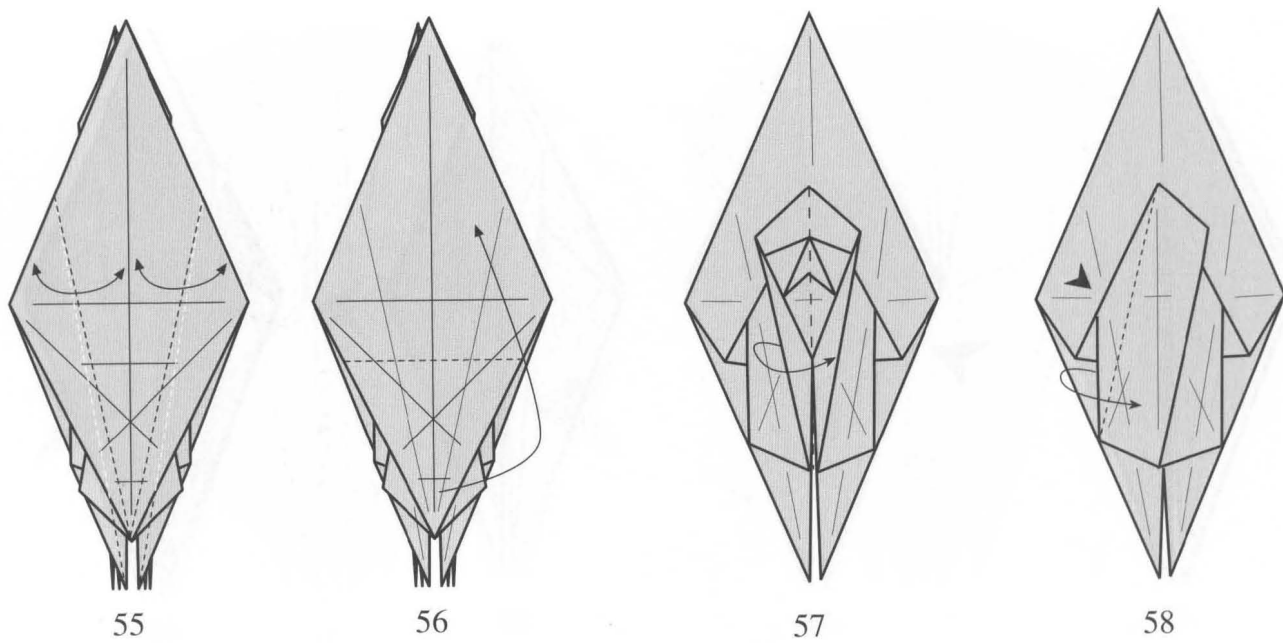
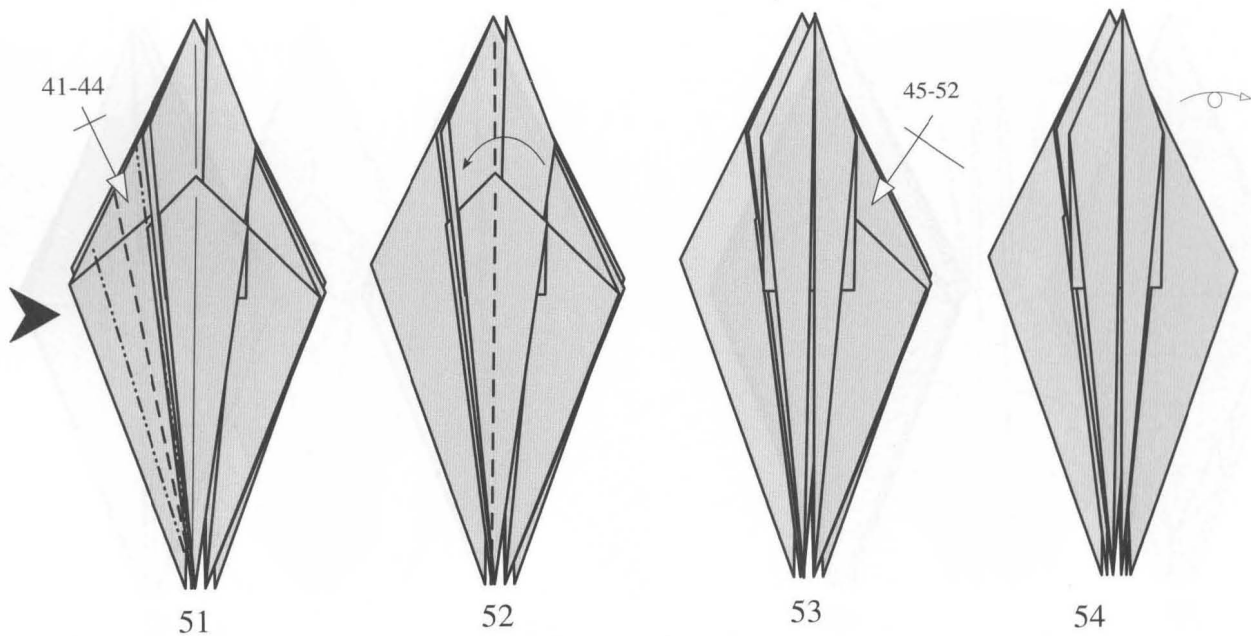
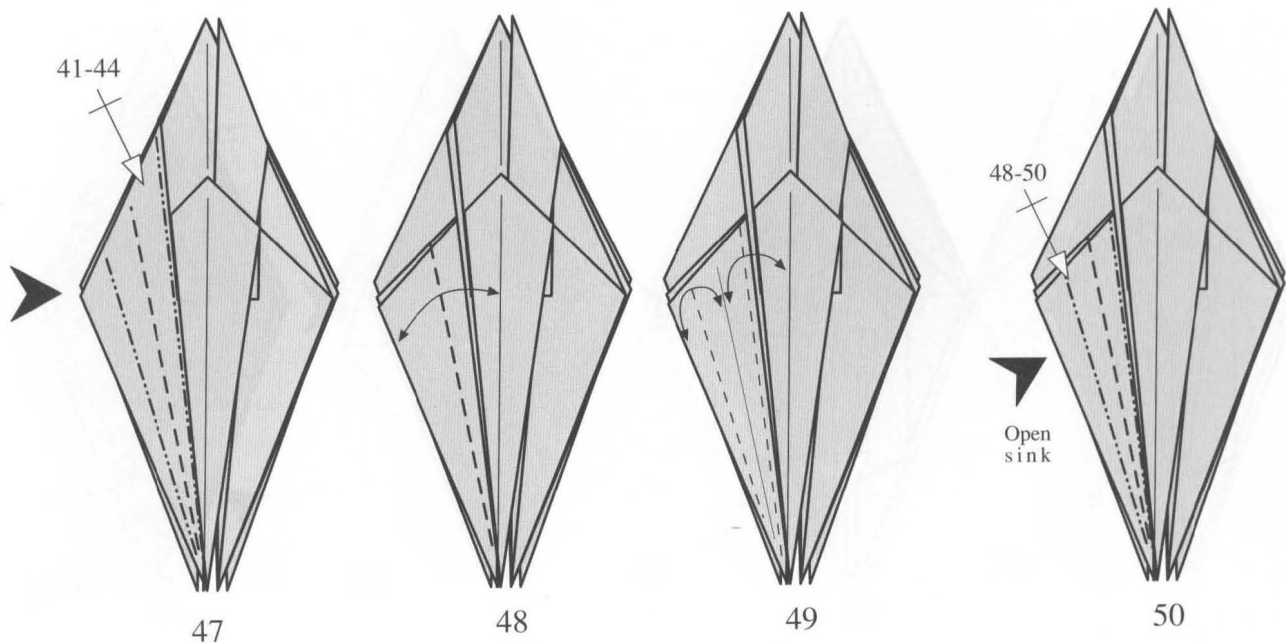

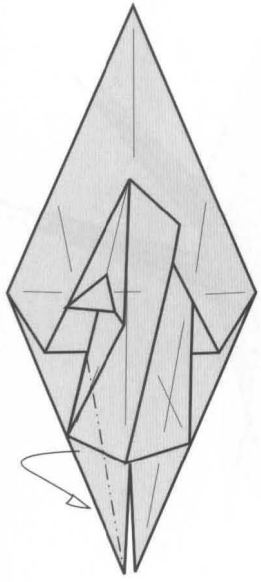

59

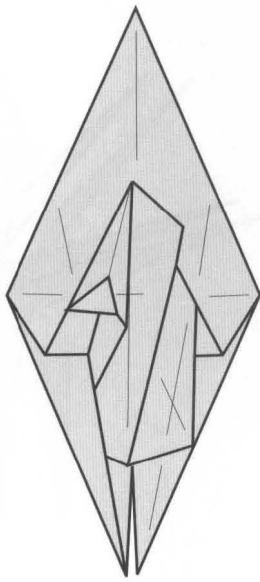

60

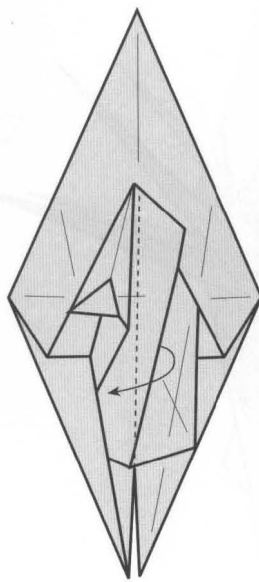

61

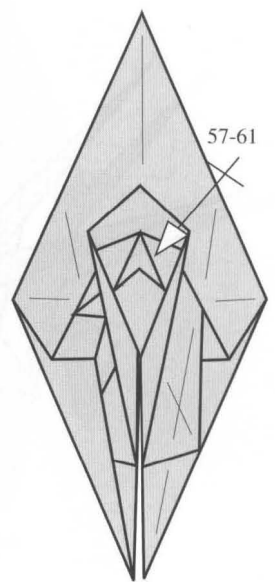

62

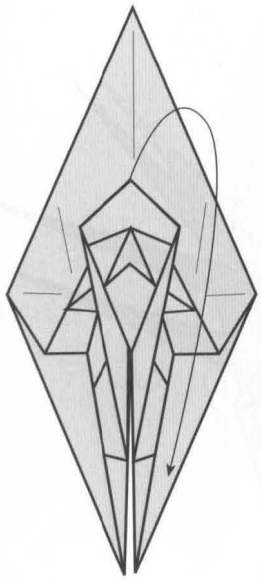

63

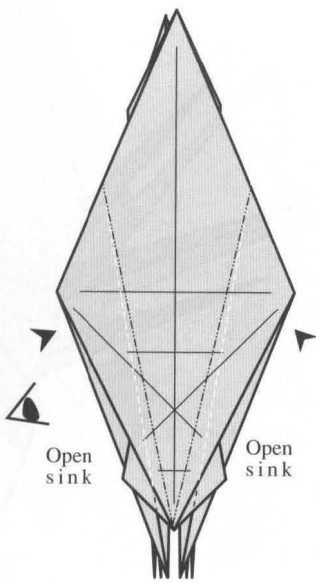

64

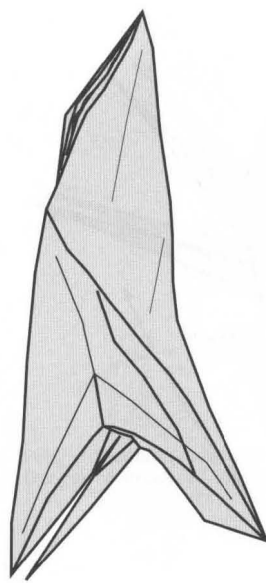

65

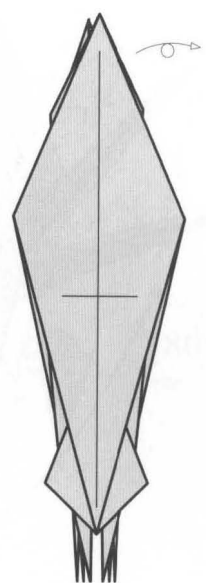

66

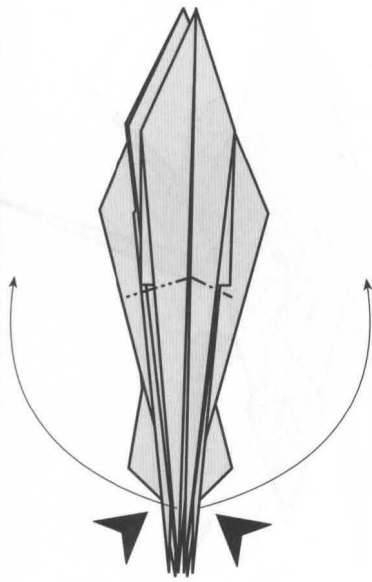

67

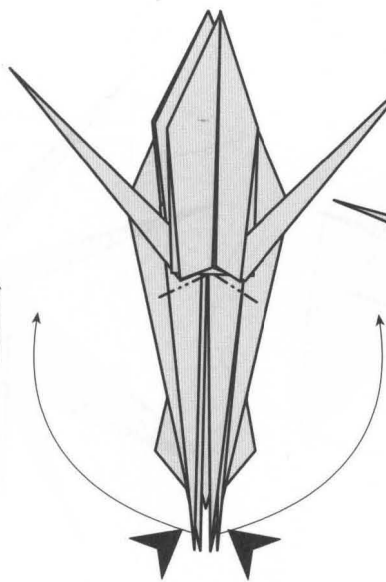

68

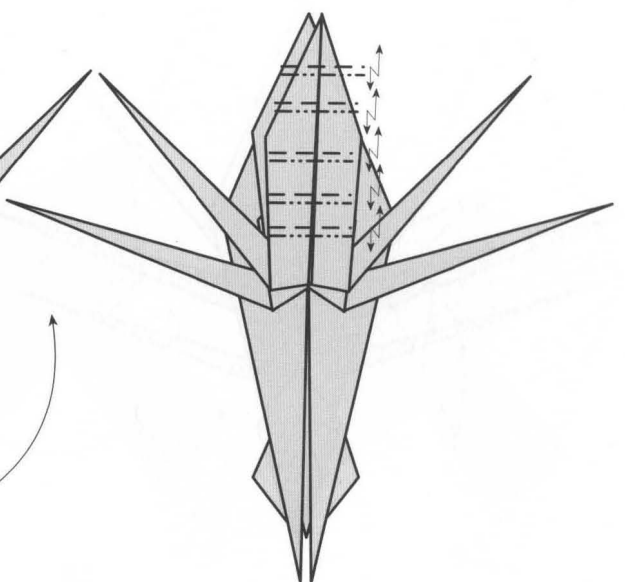

69

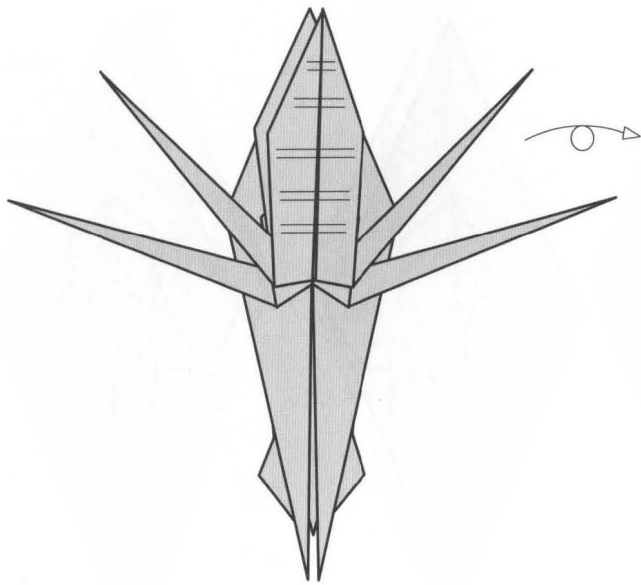

70

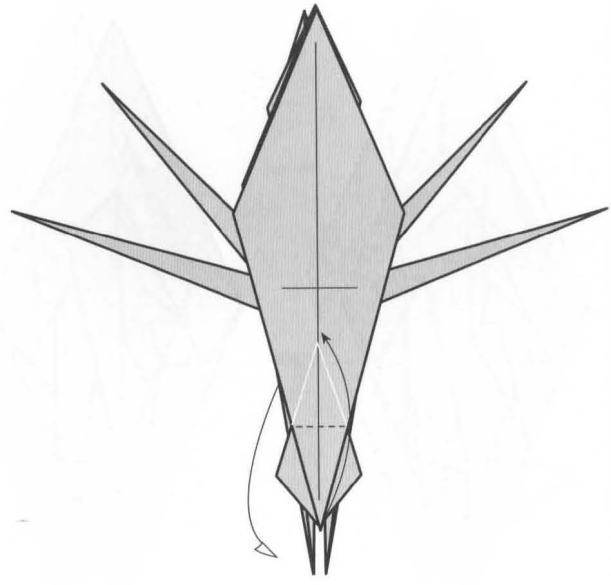

71

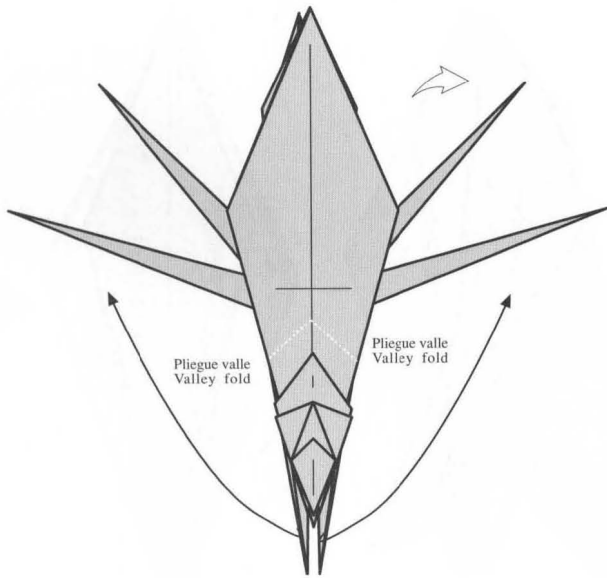

72

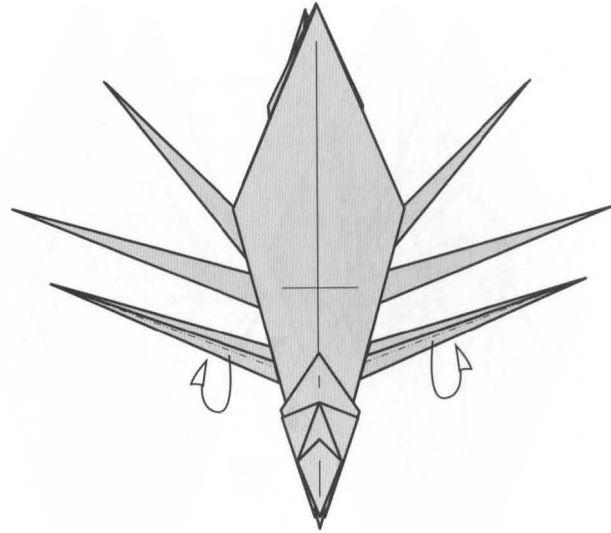

73

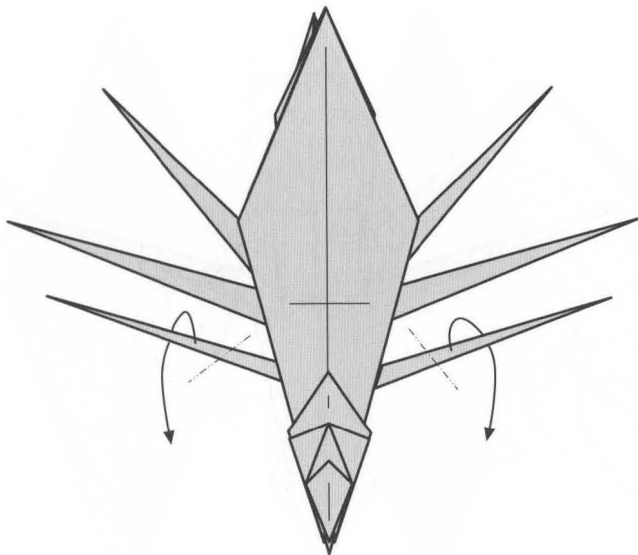

74

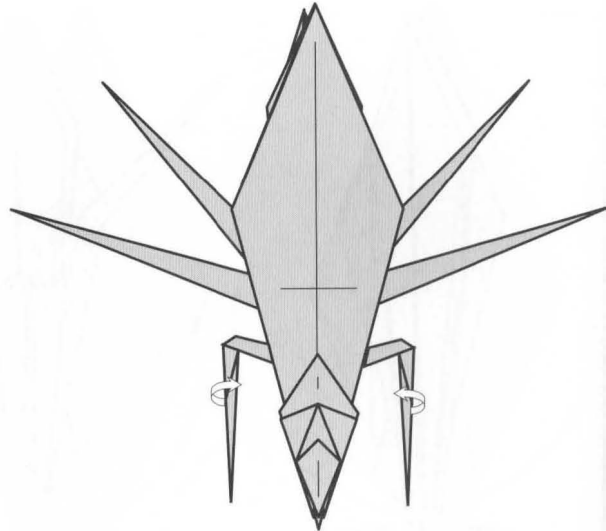

75

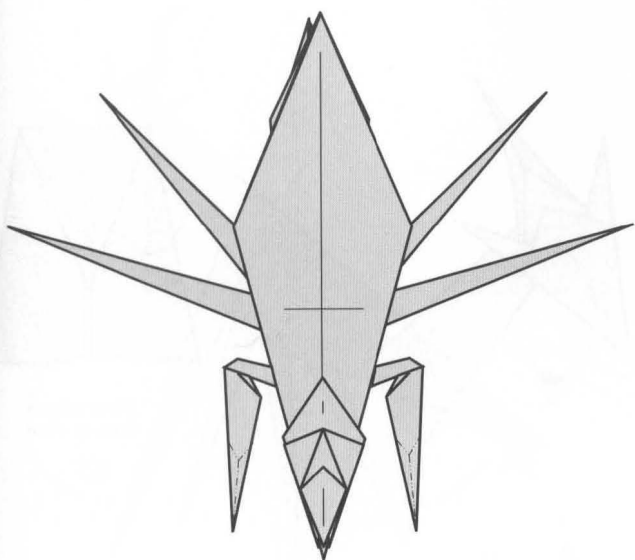

76

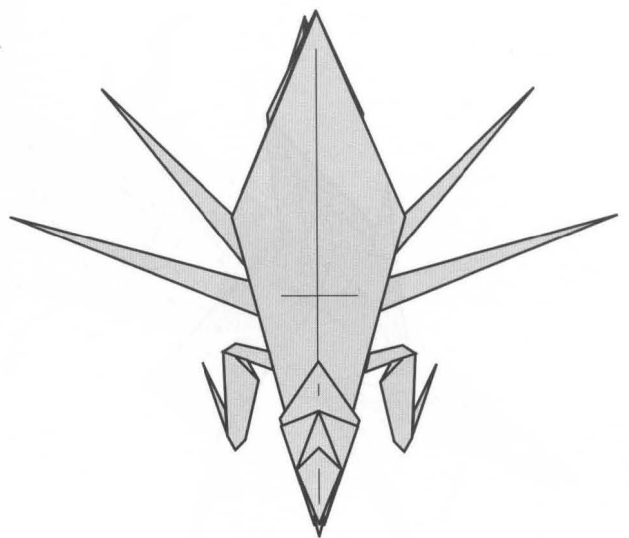

77

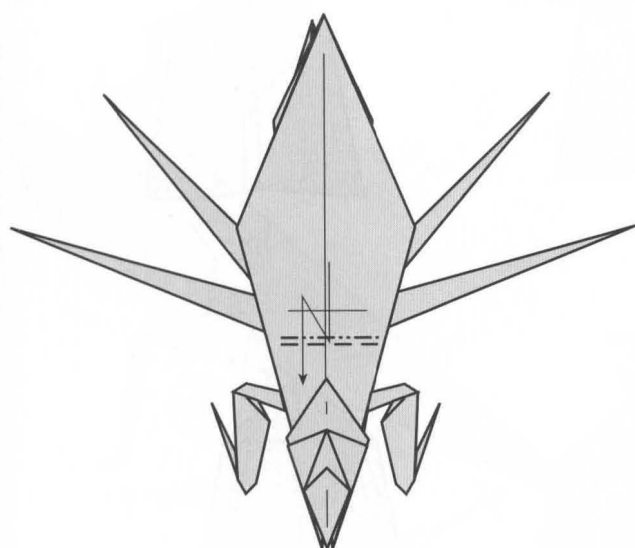

78

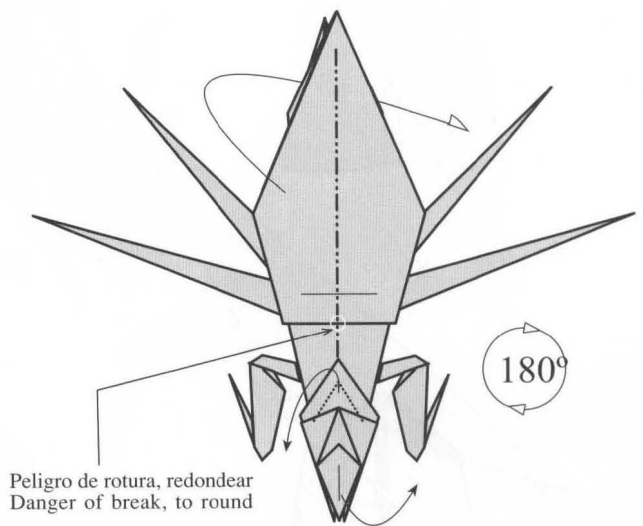

79

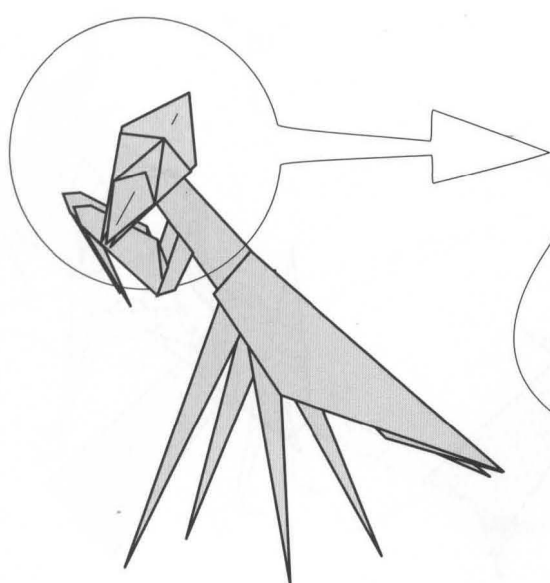

80

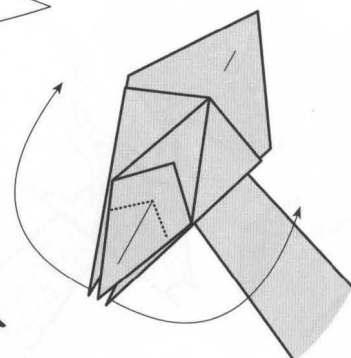

81

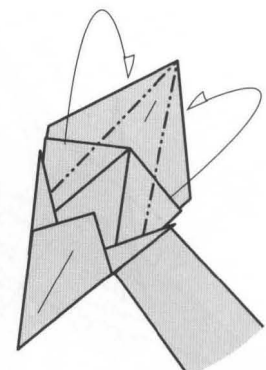

82

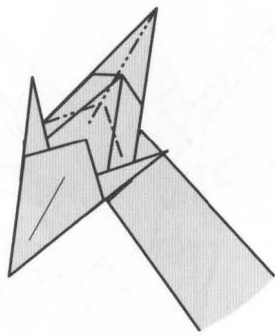

83

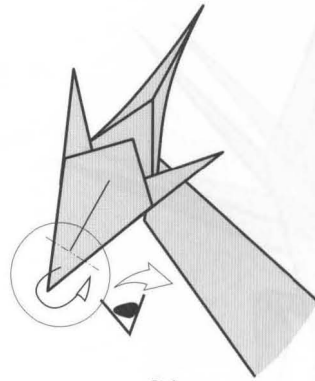

84

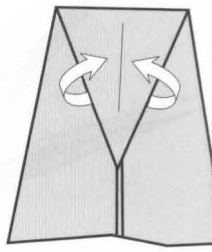

Vista inferior
bottom view

85

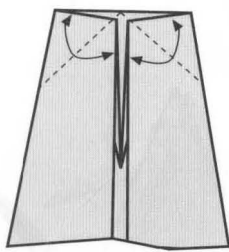

86

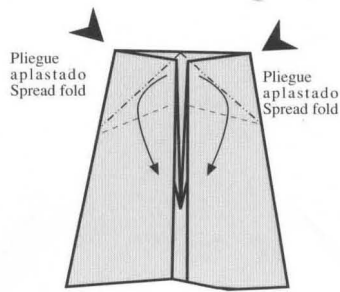

87

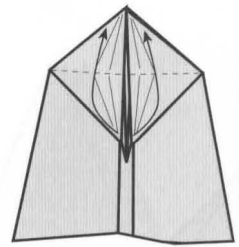

88

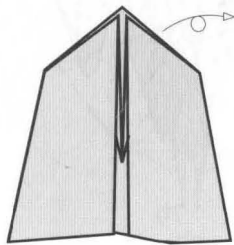

89

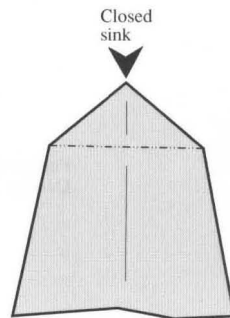

90

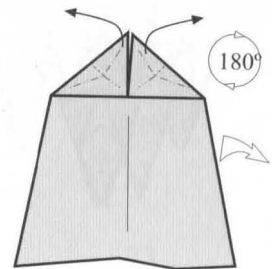

91

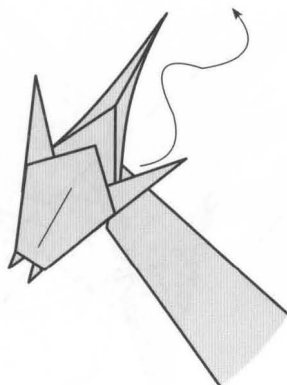

92

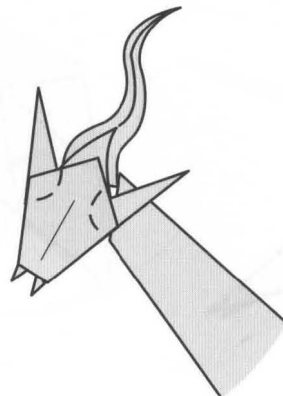

93

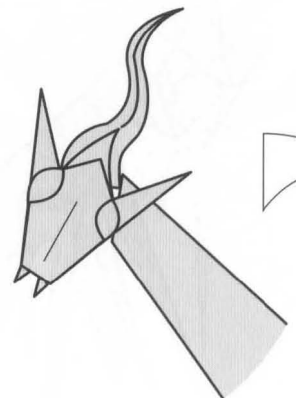

94



95

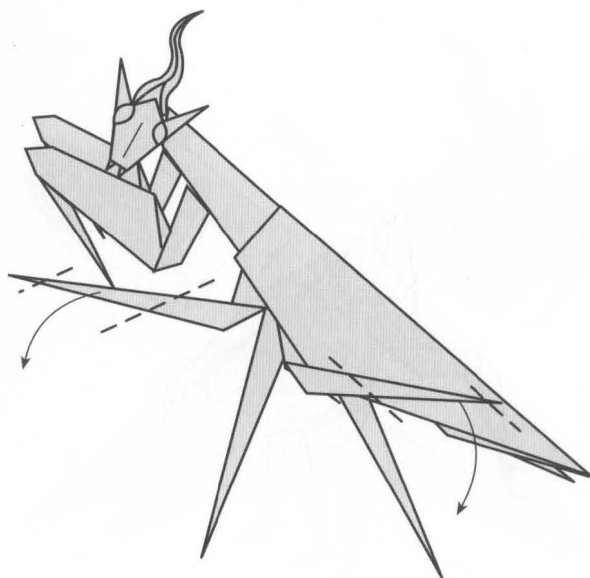

96

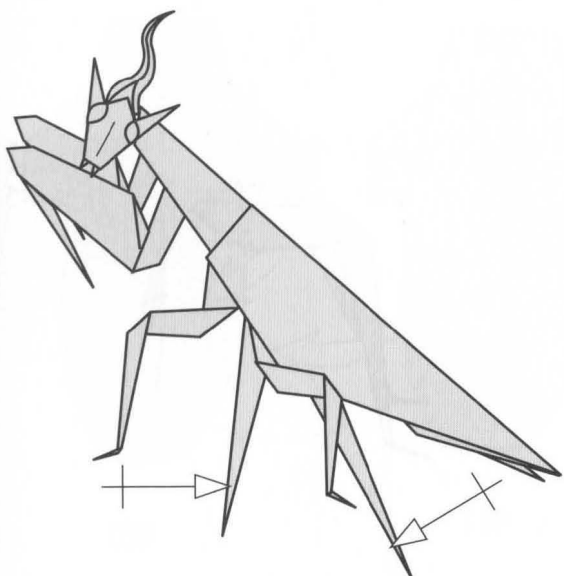

97

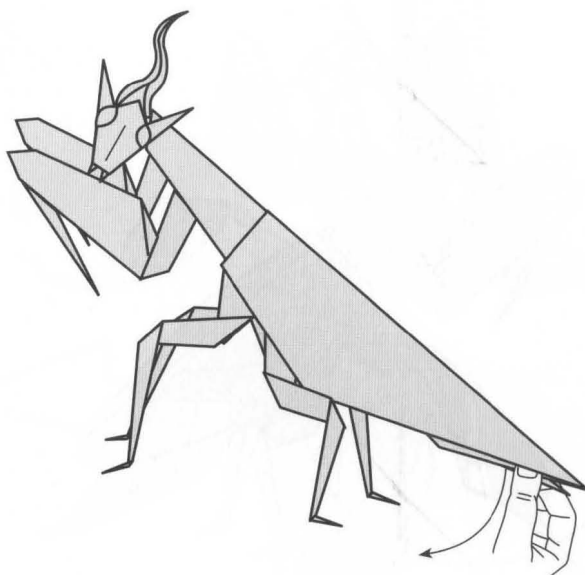

98

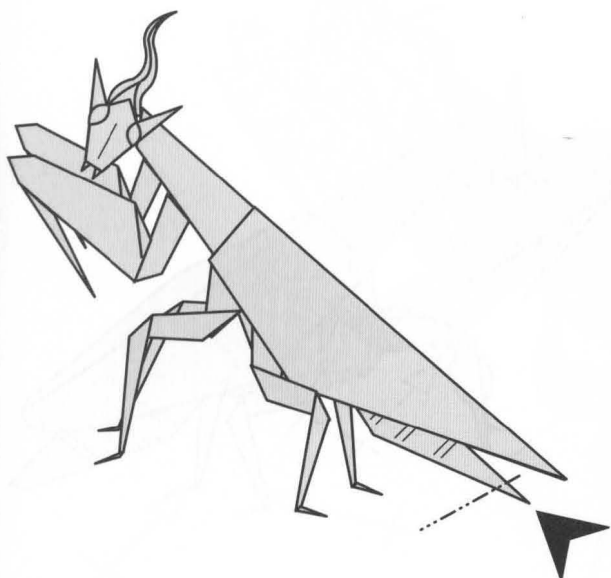

99

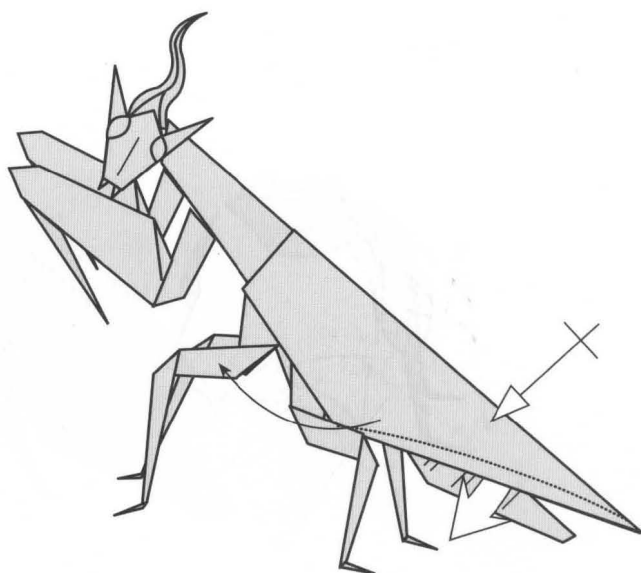

100

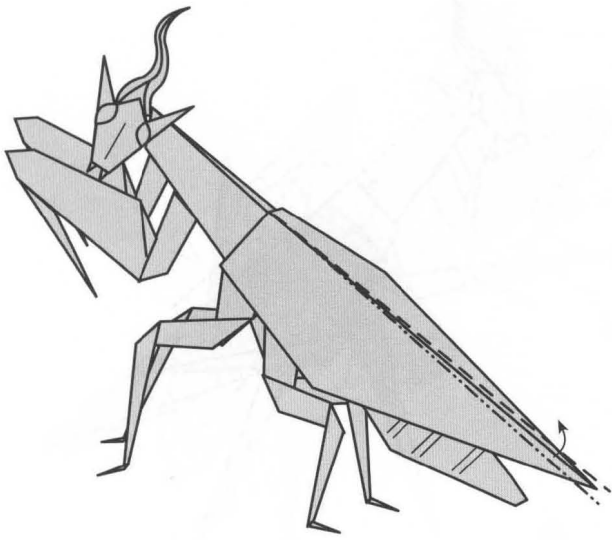

101

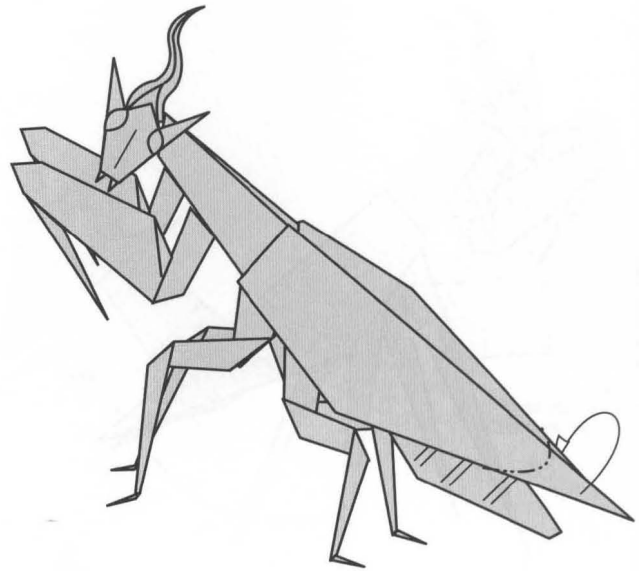

102



103

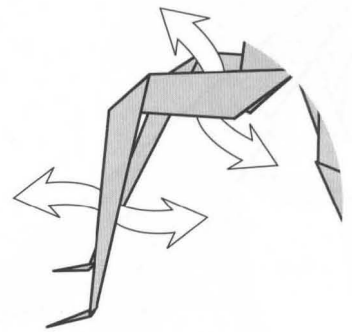

104

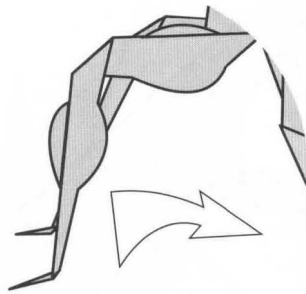

105

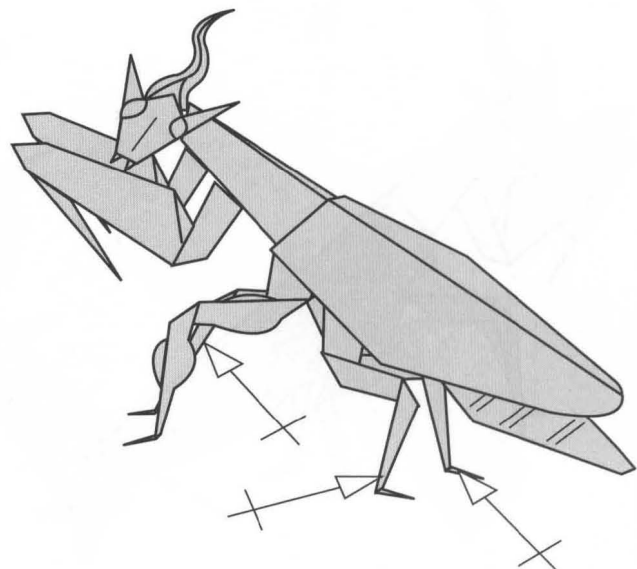

106

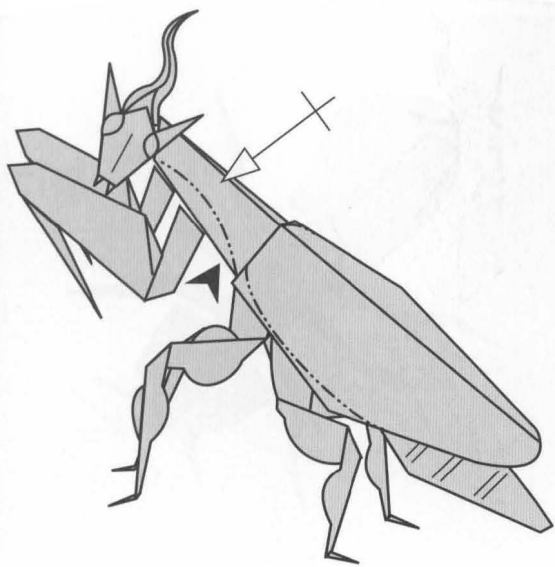

107

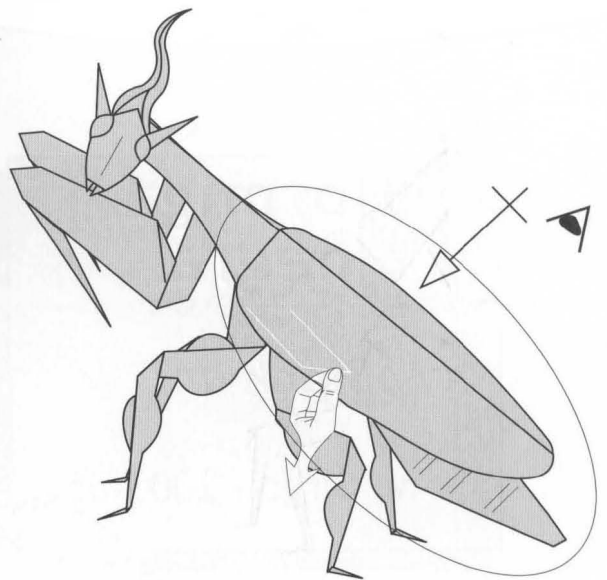

108

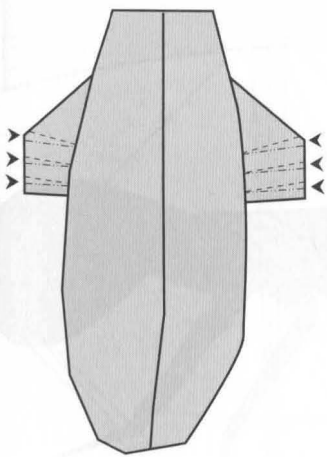

109

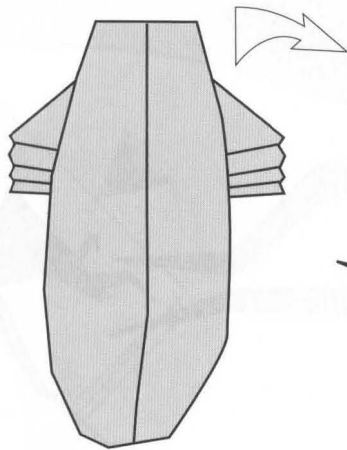

110

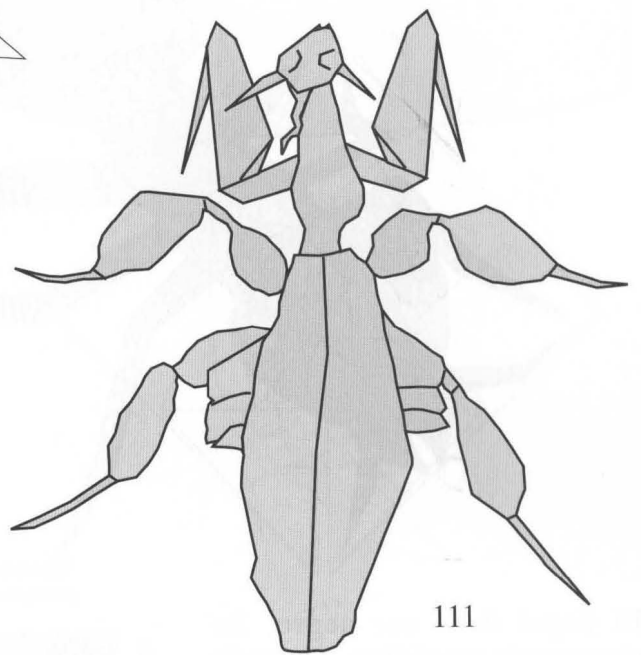

111

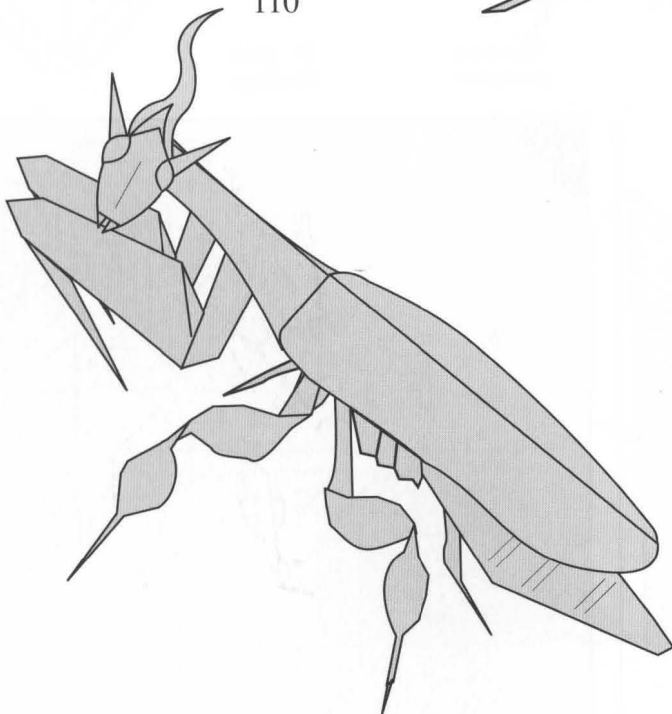

112

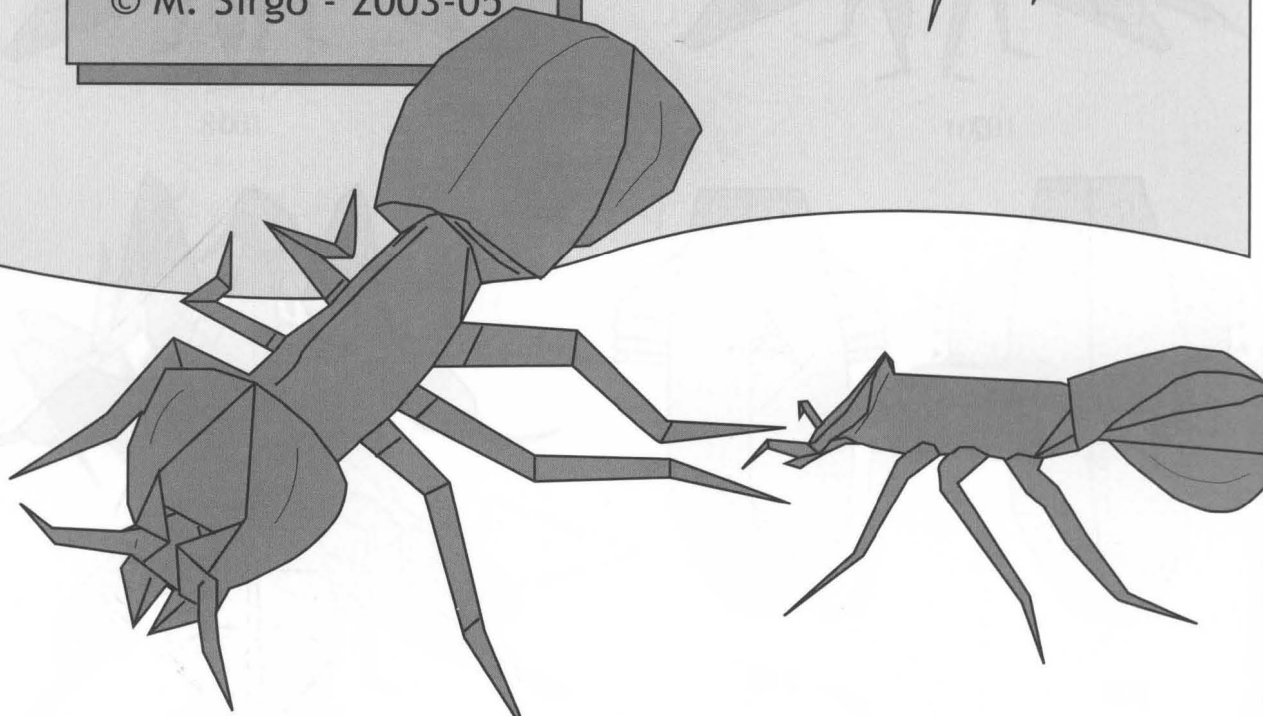
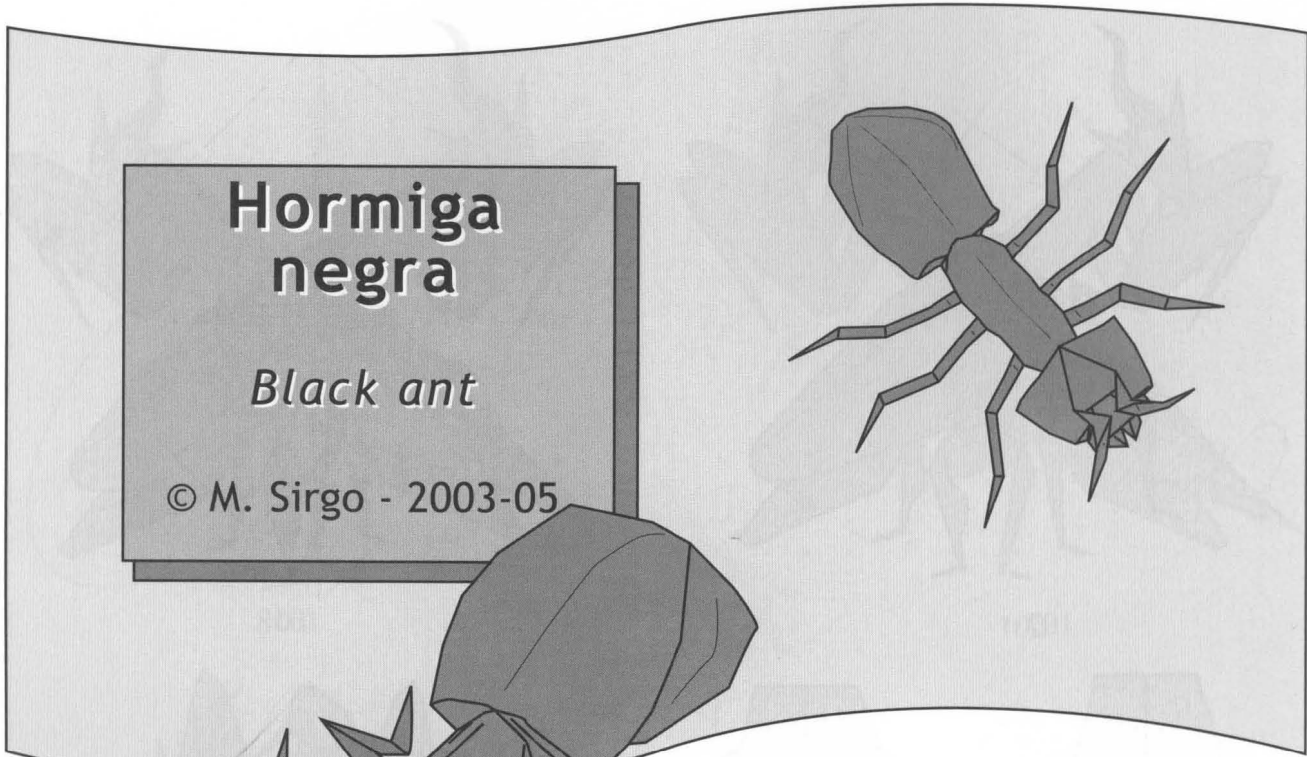

Antena
Antennae

1ª pata
Forelegs

2ª pata
Hindlegs

El papel debe ser negro. Se recomienda papel fino, menor de 40 gramos, doble seda, banana, lokta, metalizado o *sandwich* de 25x25 cm o mayor.

The paper should be black. Fine paper is recommended, smaller than 40 grams, double silk, banana tree, lokta, metalized or sandwich of 25x25 cm or bigger.

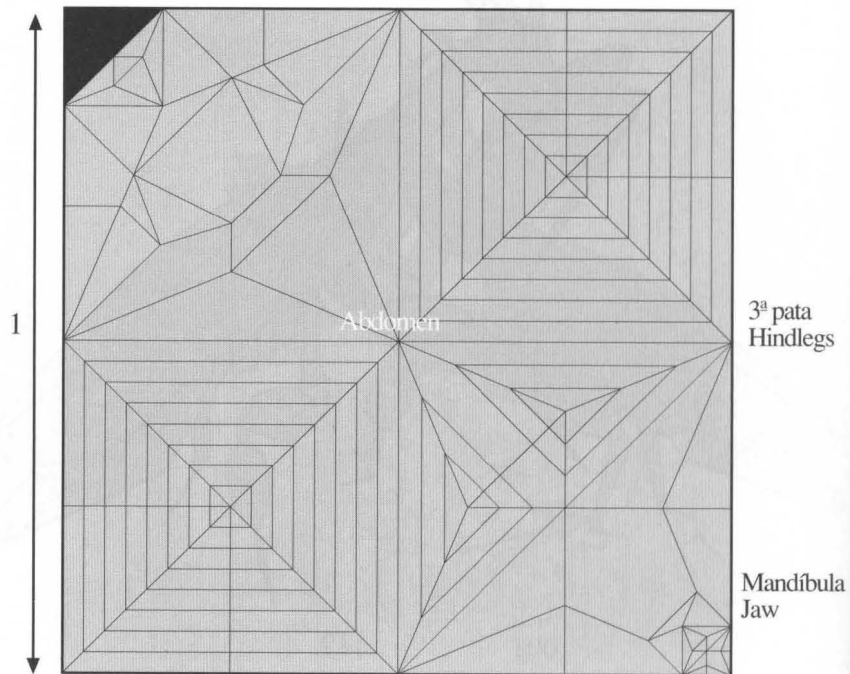
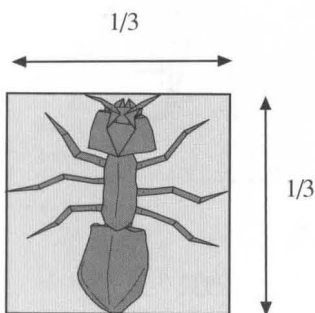

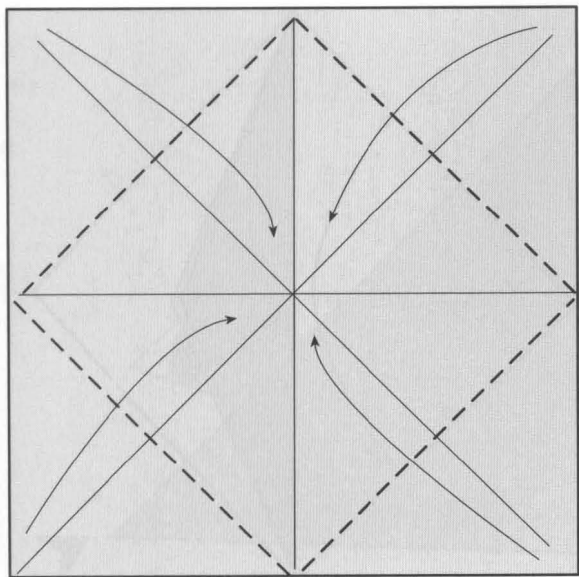

1

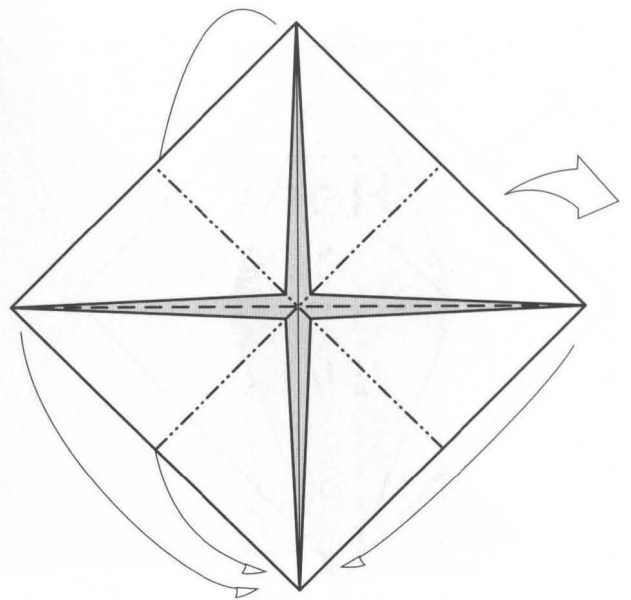

2

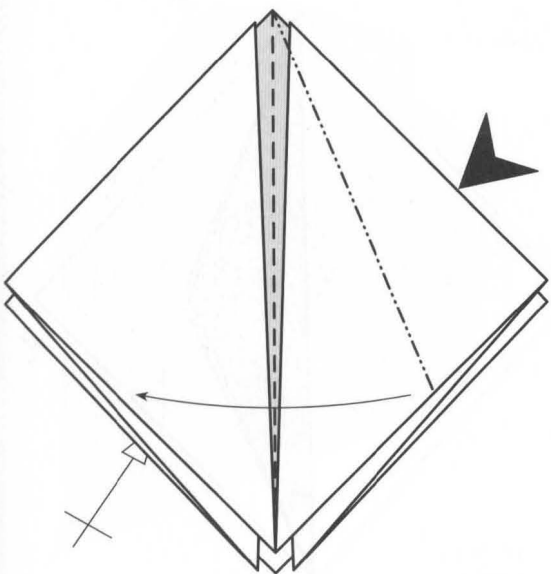

3

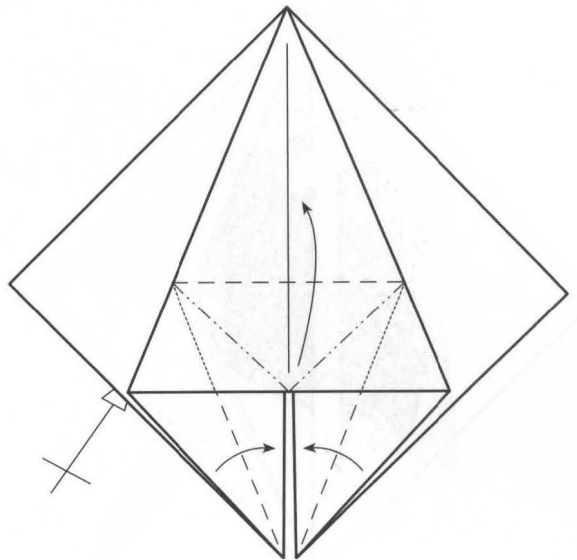

4

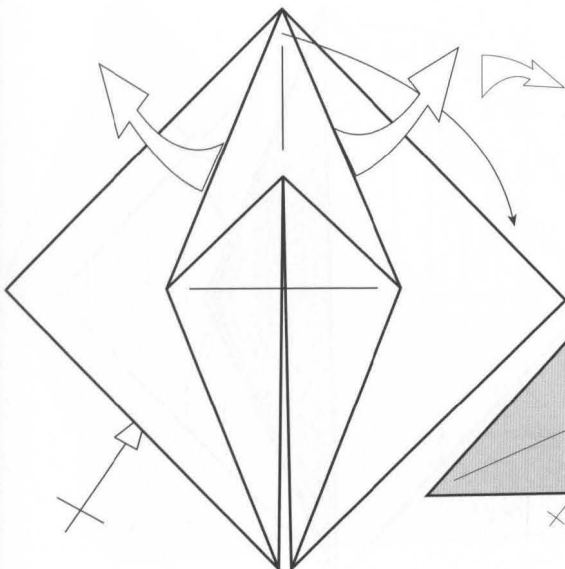

5

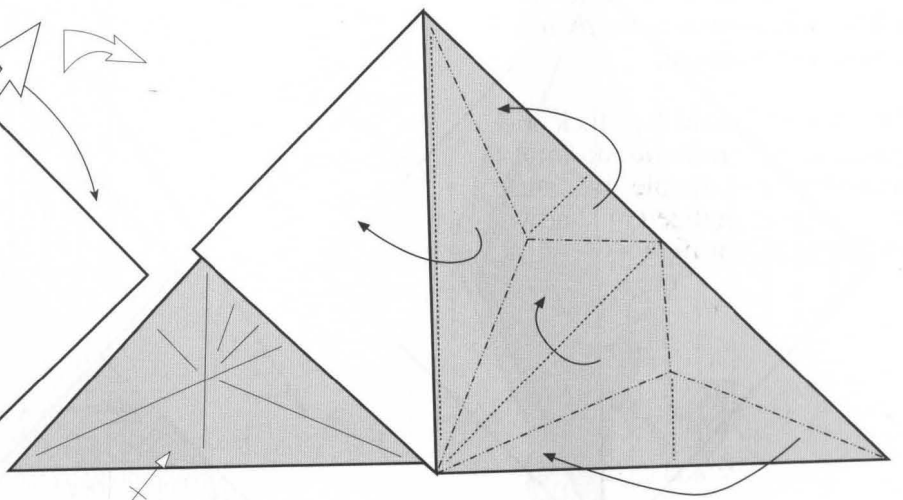

6

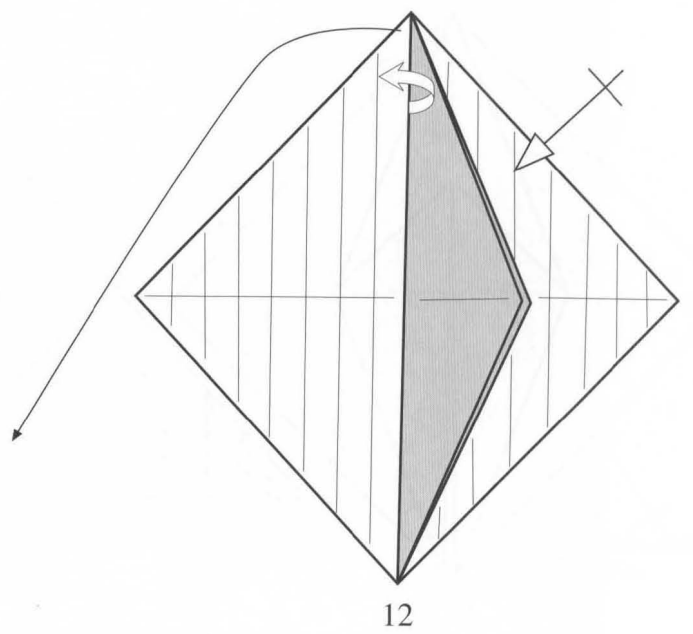
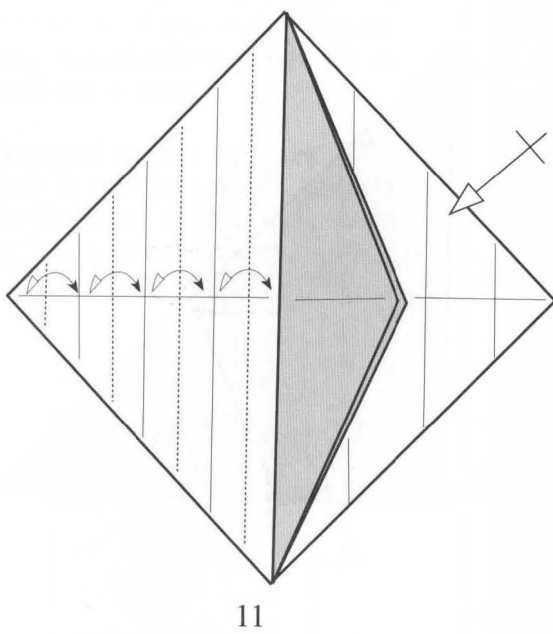
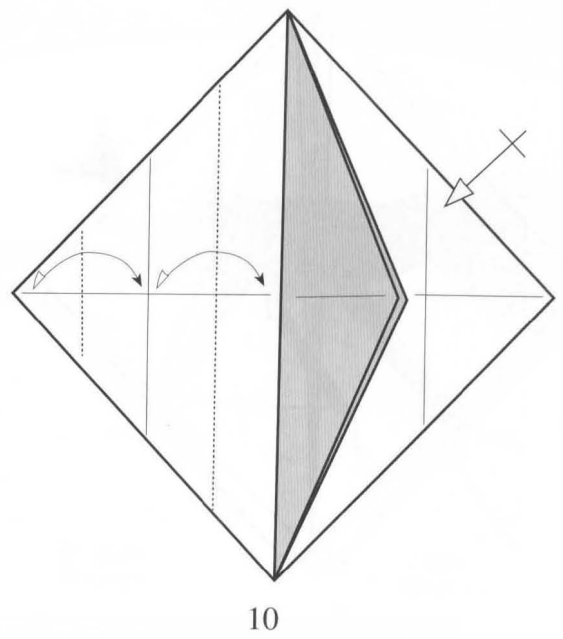
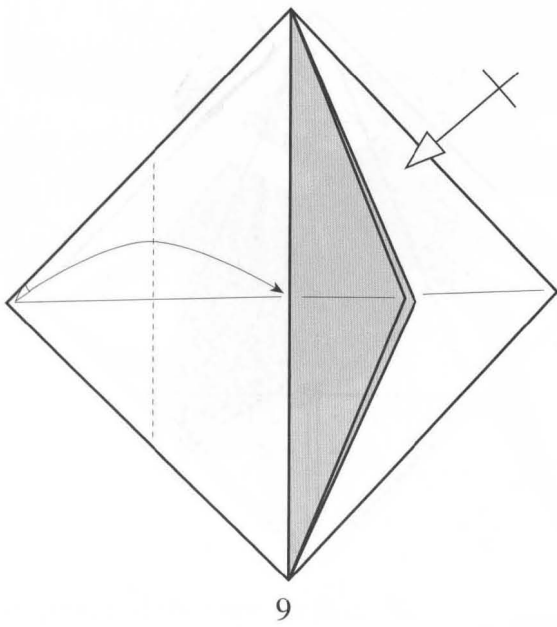
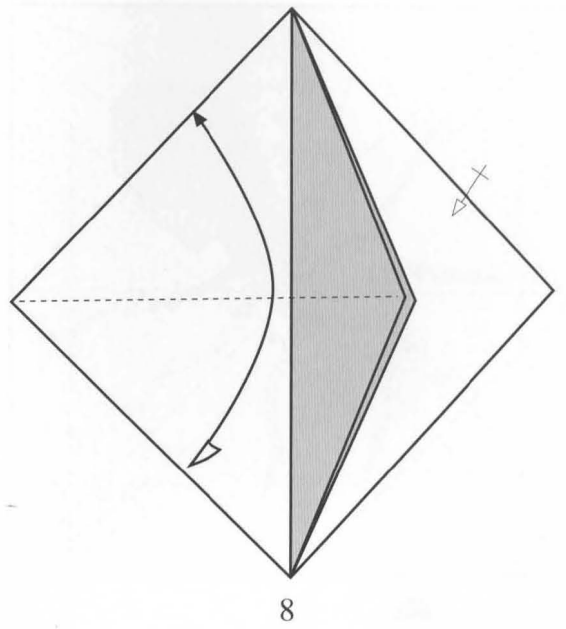
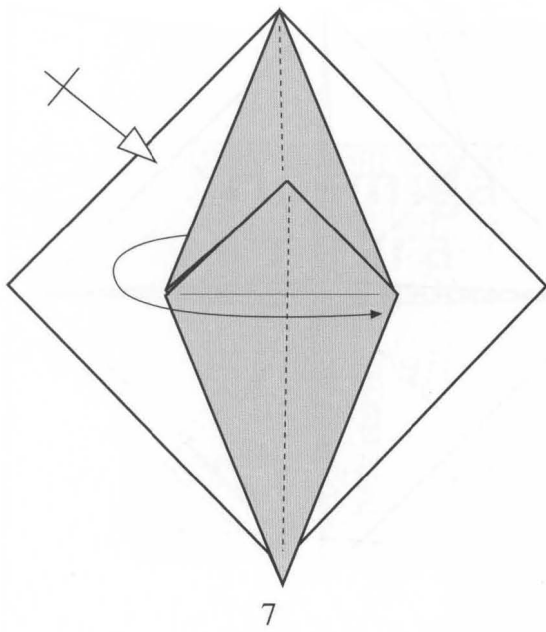

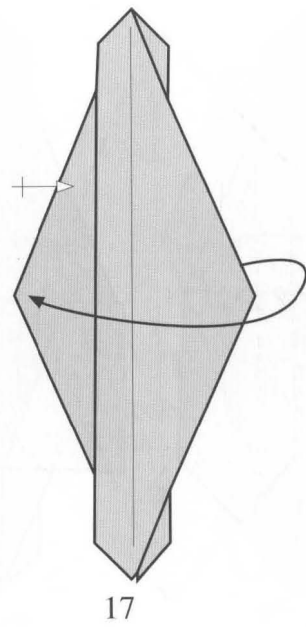
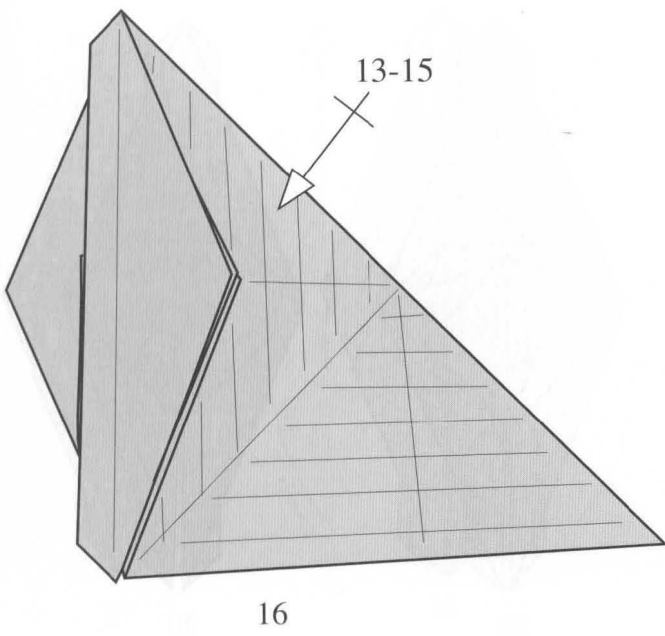
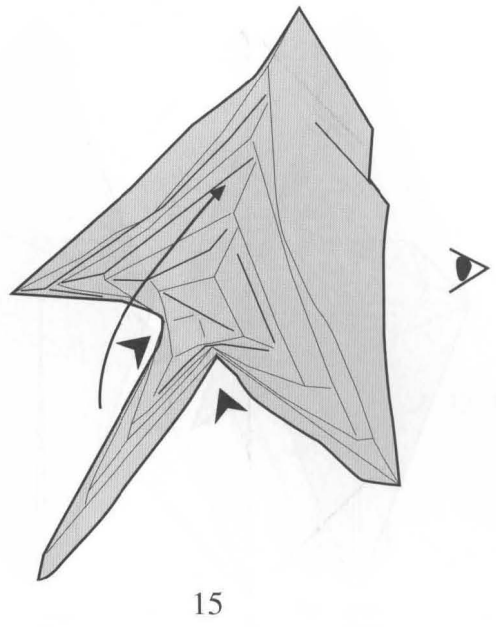
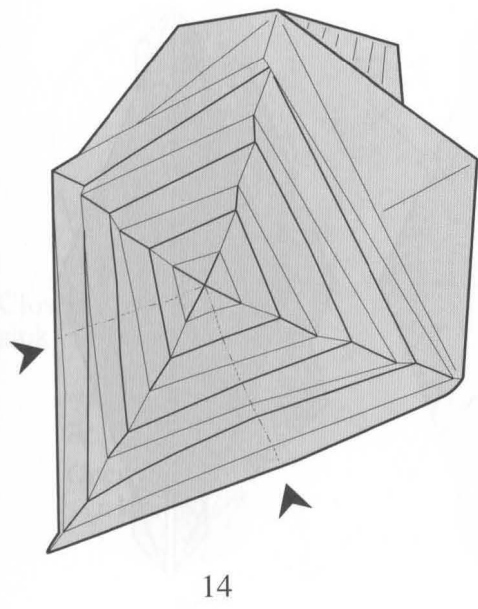
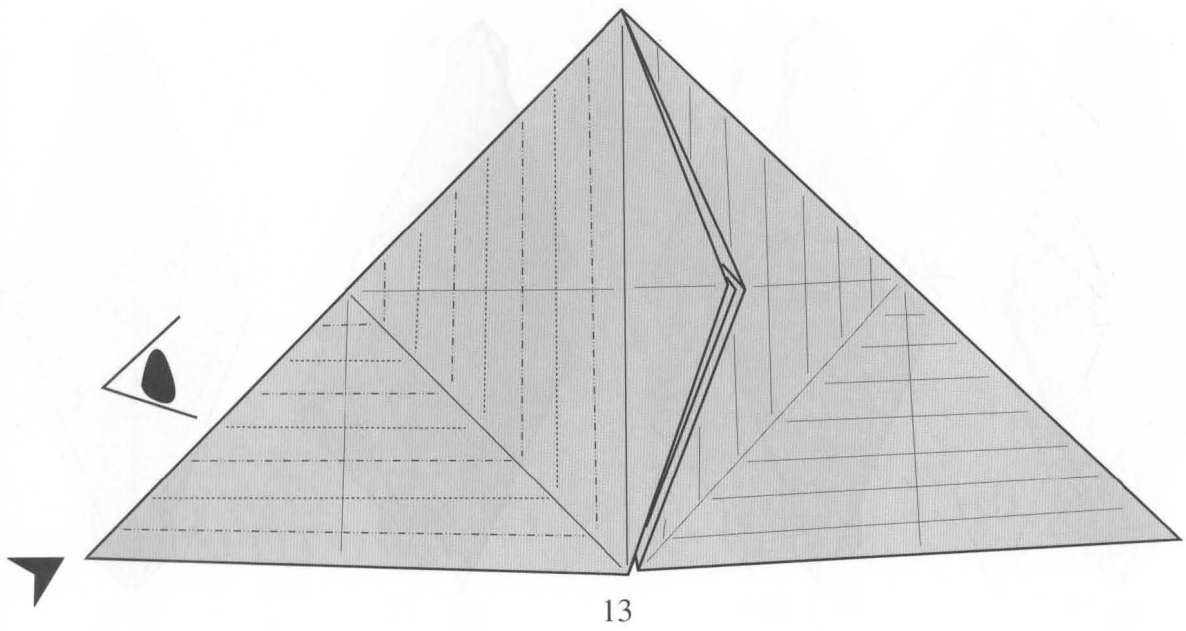

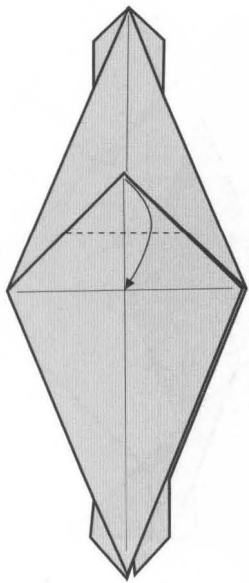

18

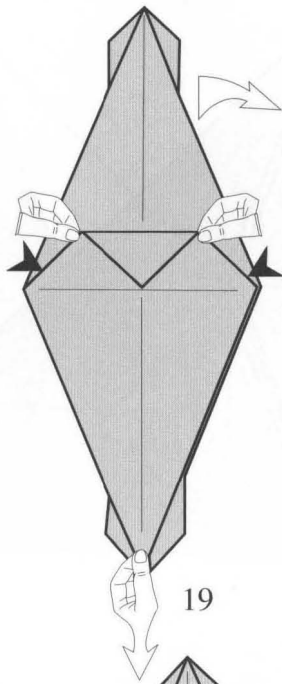

19

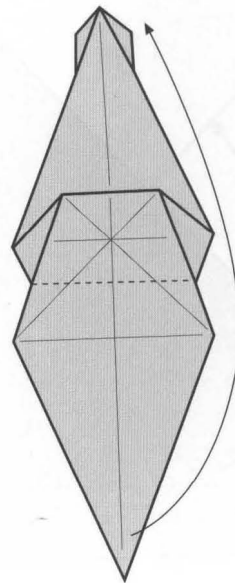

20

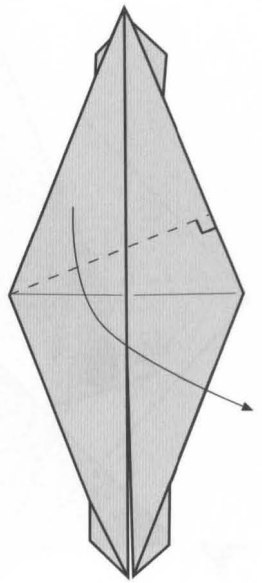

21

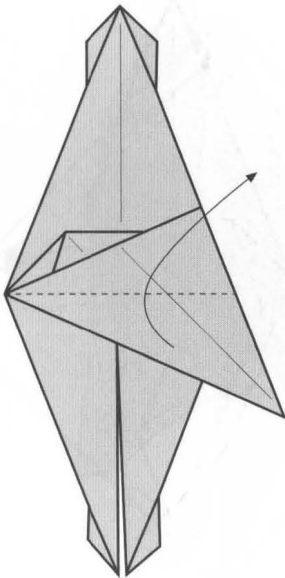

22

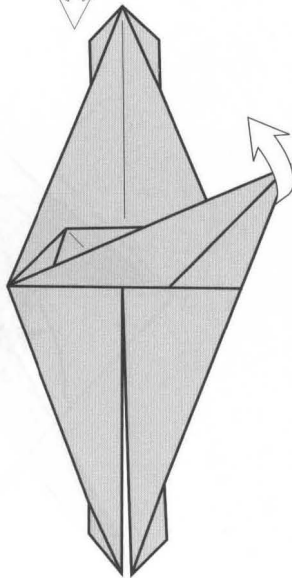

23

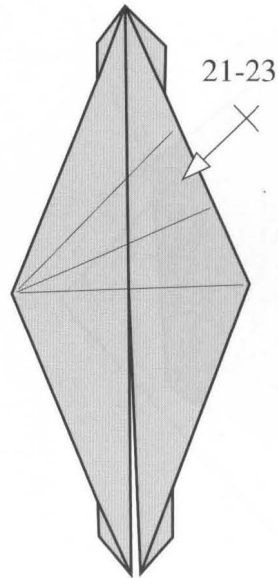

24

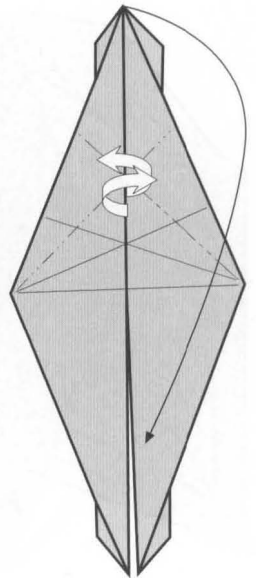

25

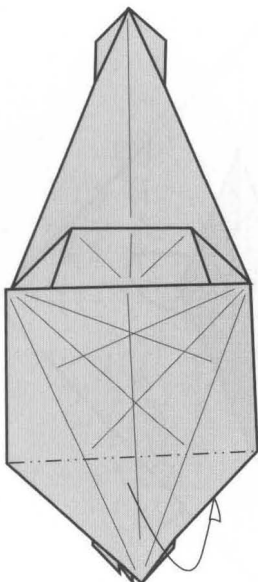

26

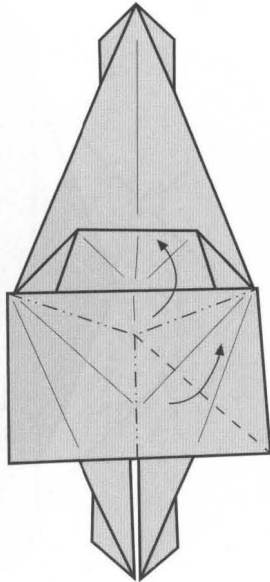

27

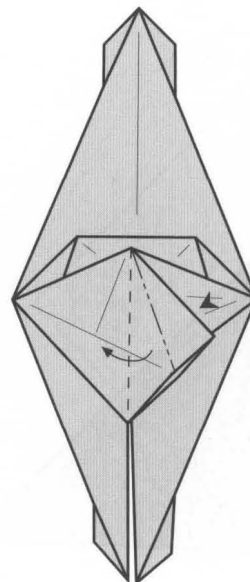

28

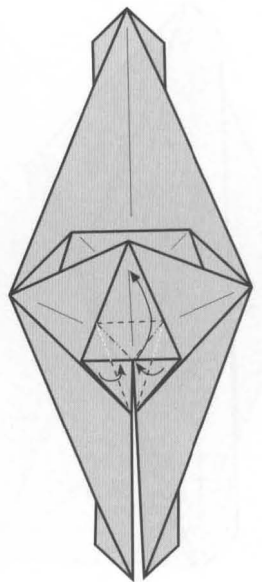

29

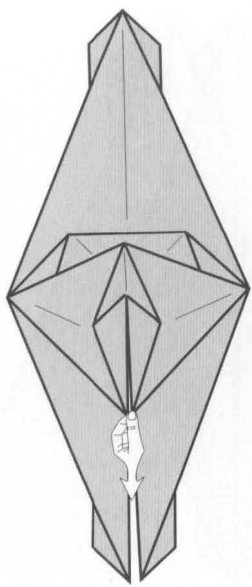

30

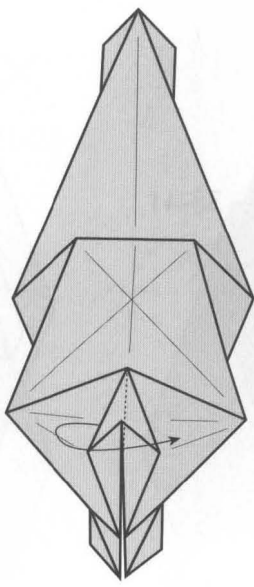

31

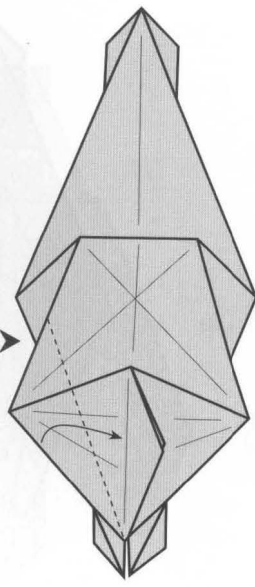

32

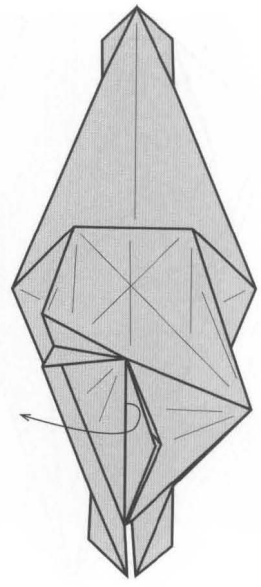

33

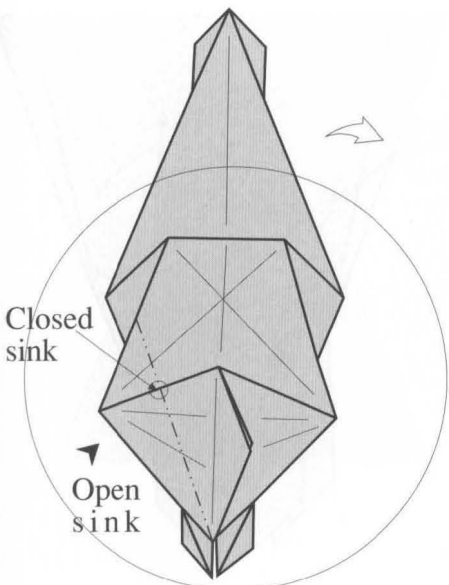

34

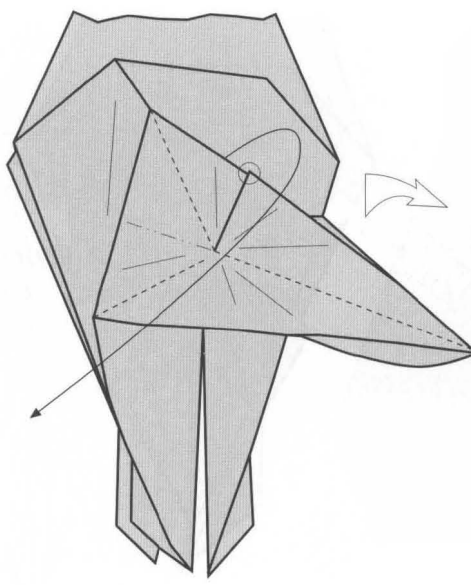

35

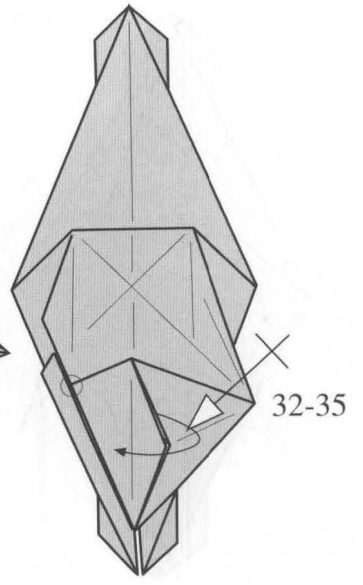

36

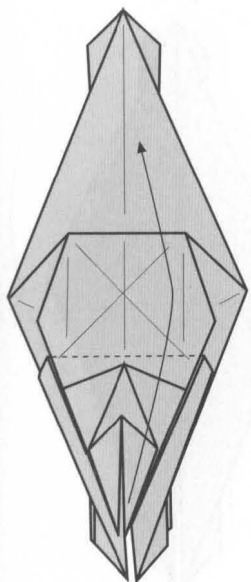

37

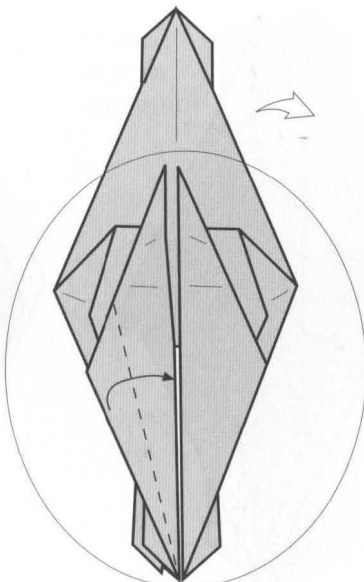

38

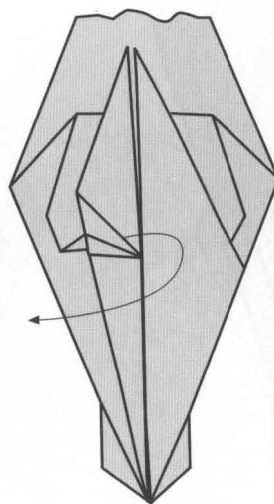

39

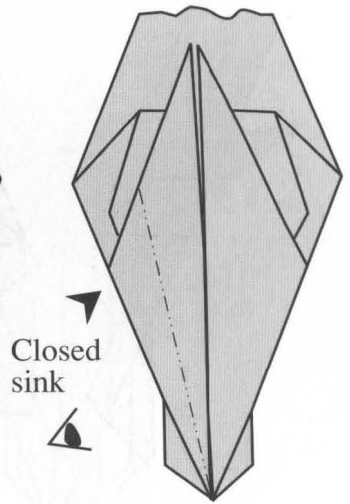

40

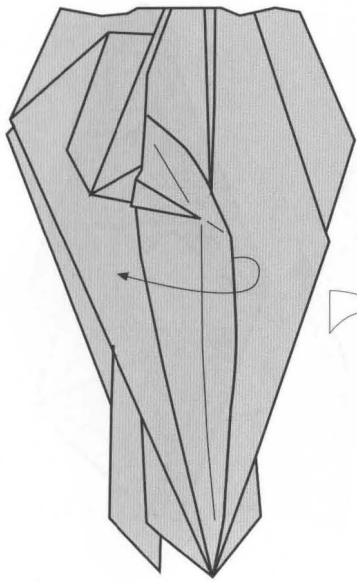

41

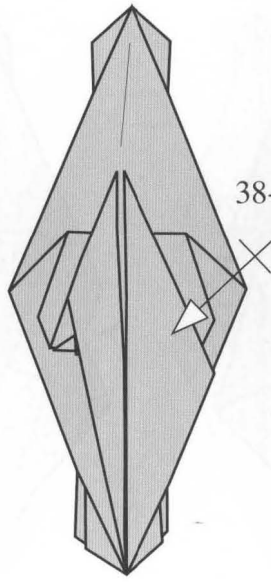

38-41

42

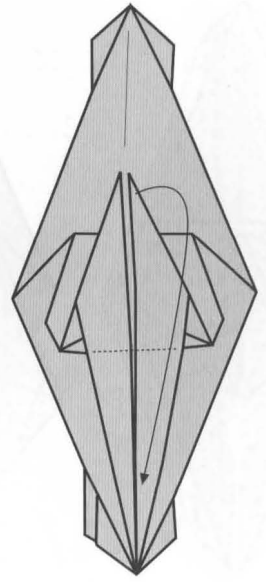

43

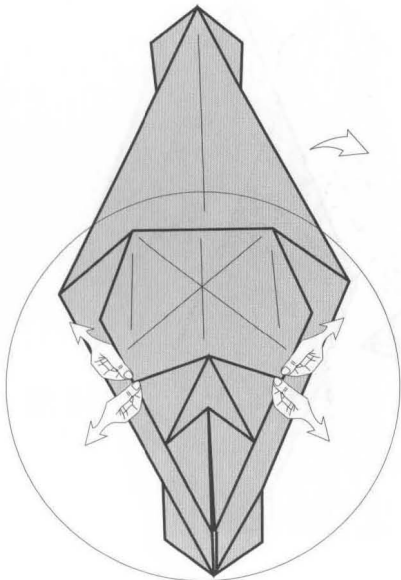

44

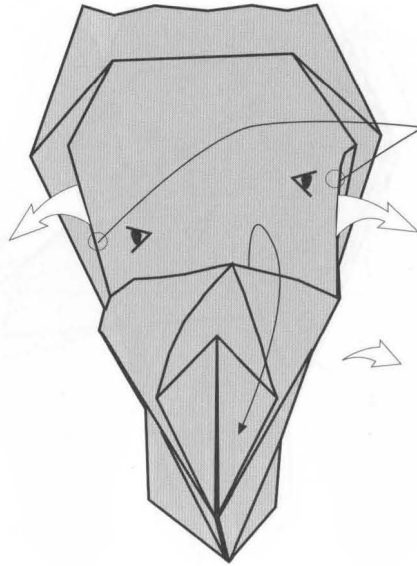

45

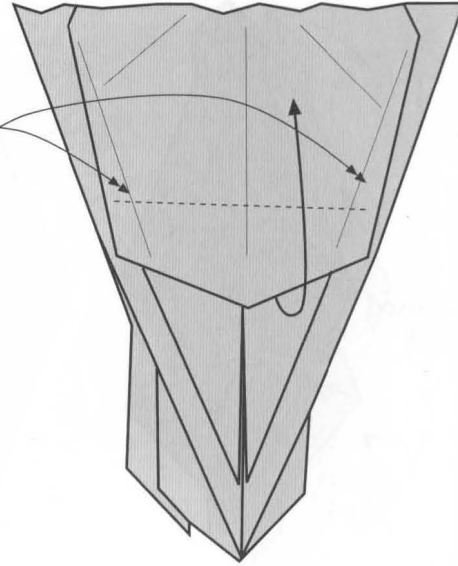

46

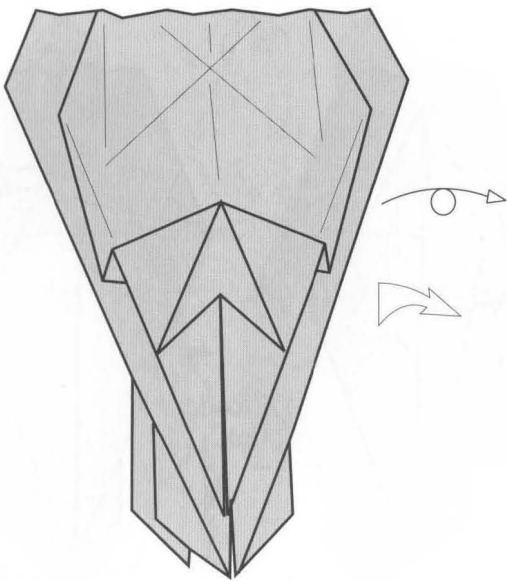

47

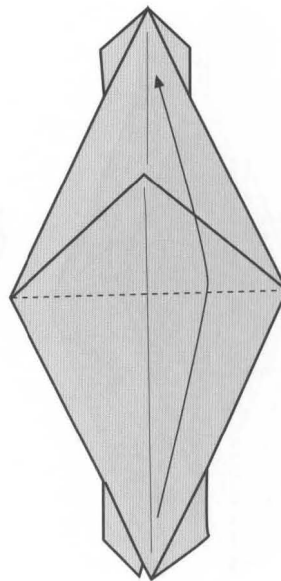

48

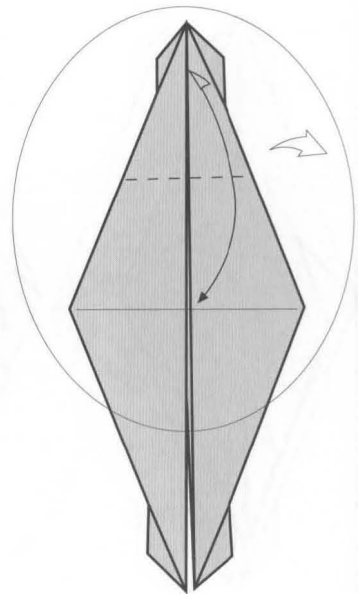

49

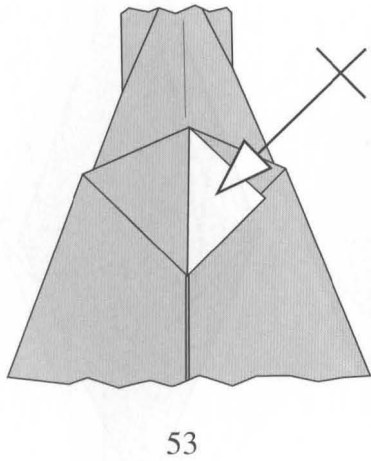
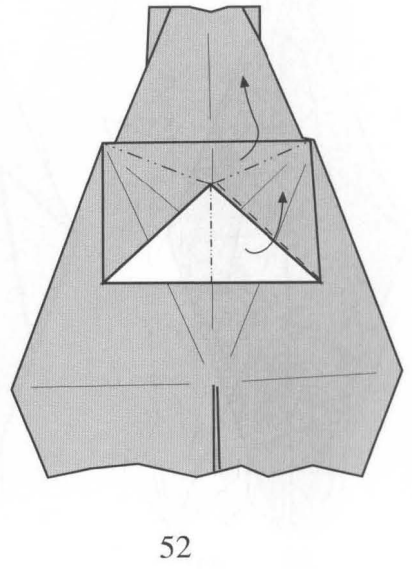
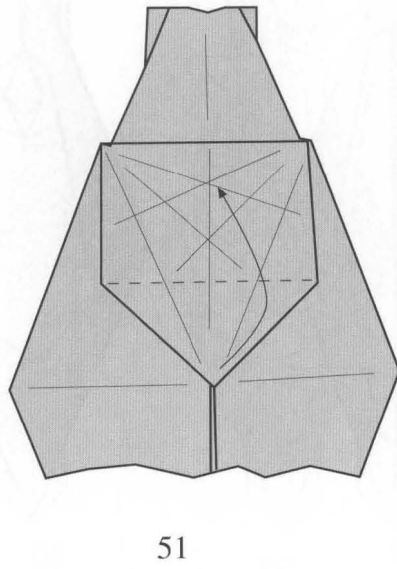
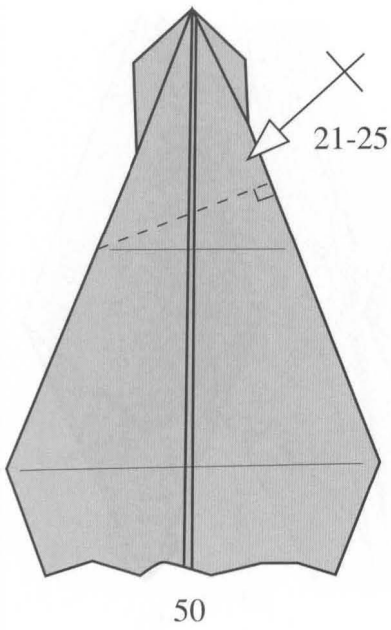

3-6 sólo esta cara

Only this face

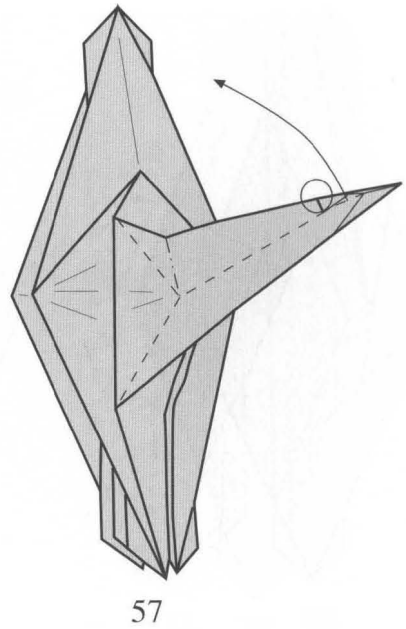
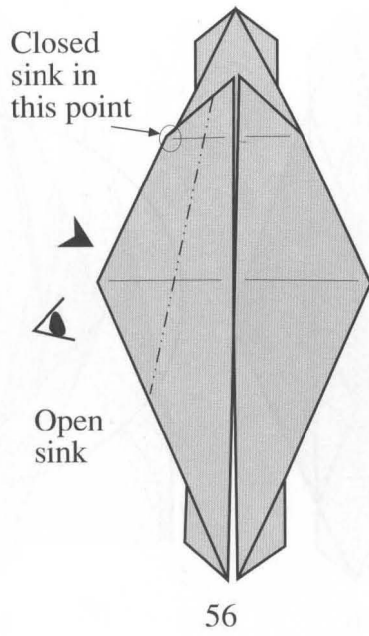
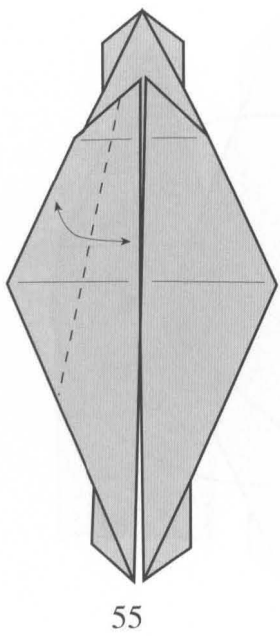
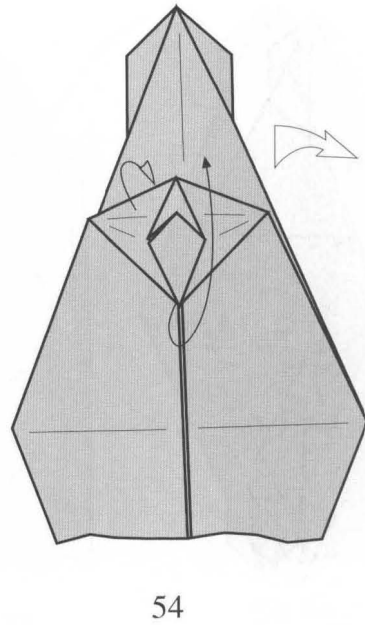

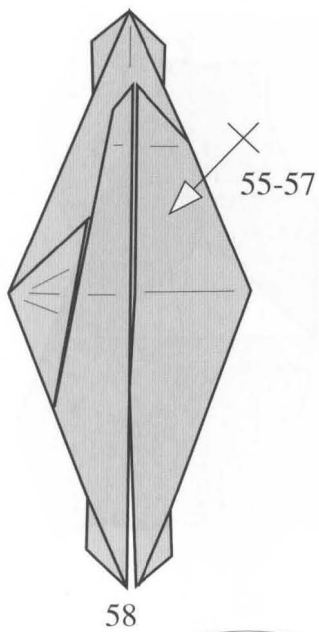

58

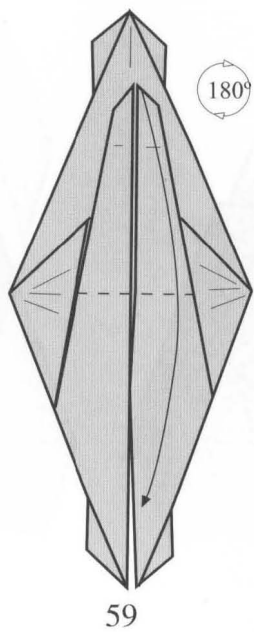

59

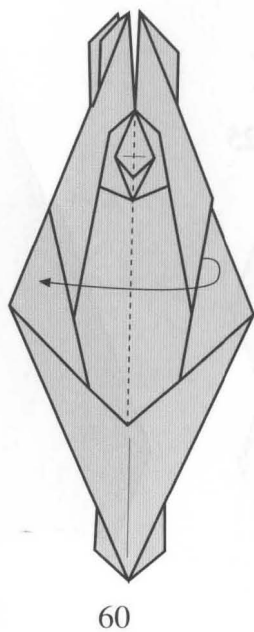

60

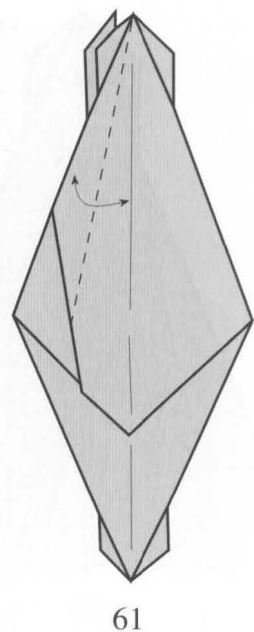

61

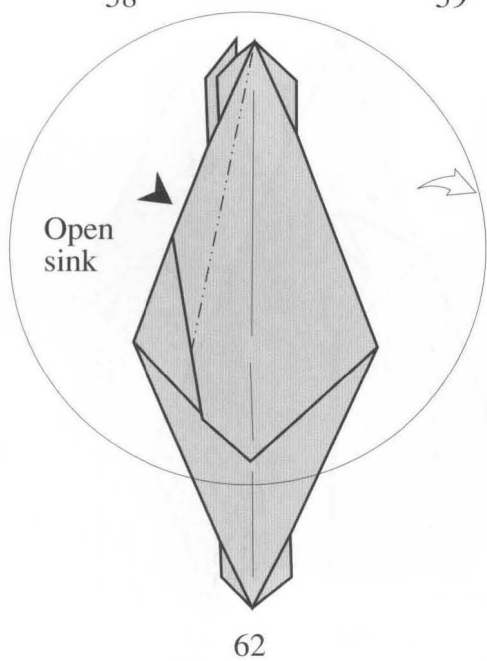

62

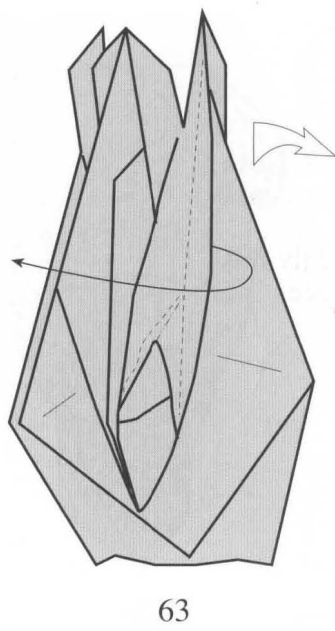

63

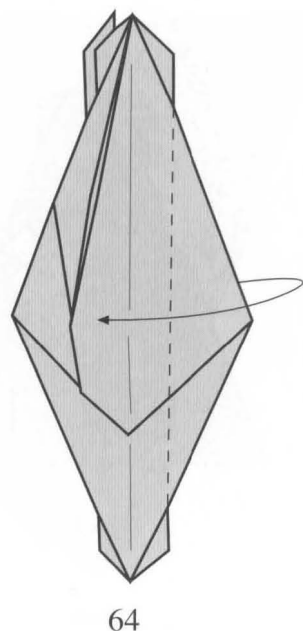

64

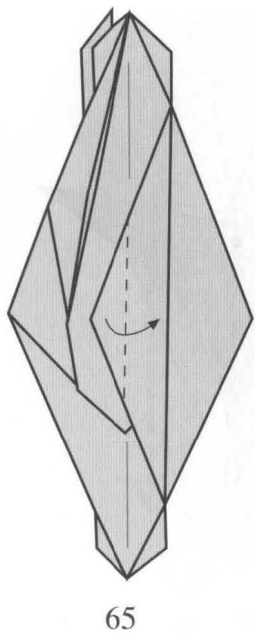

65

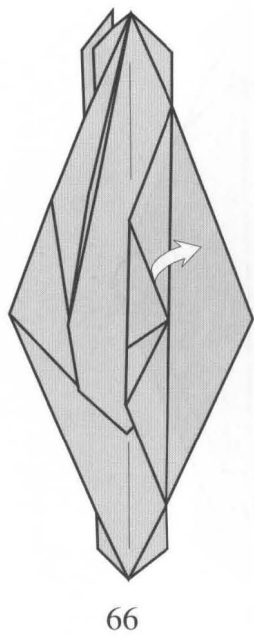

66

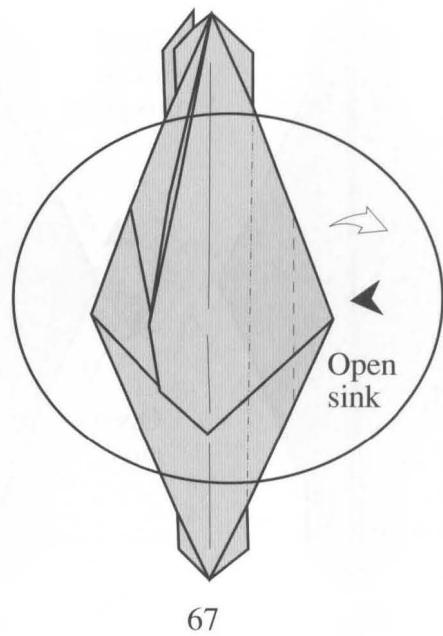

67

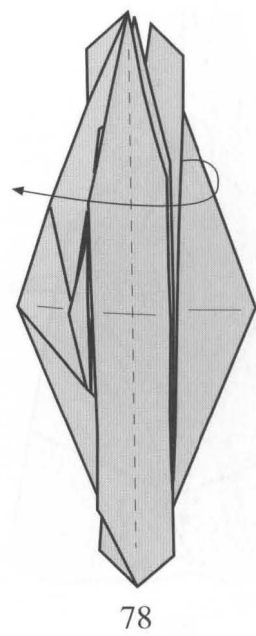
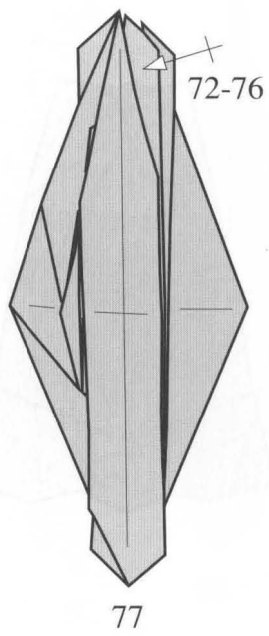
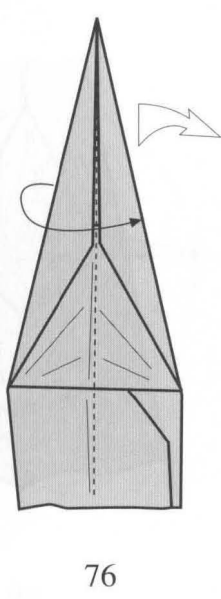
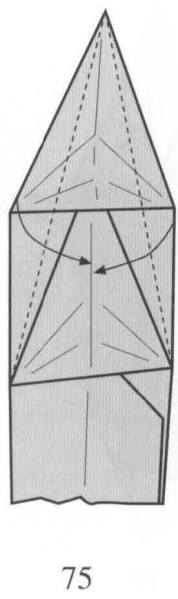
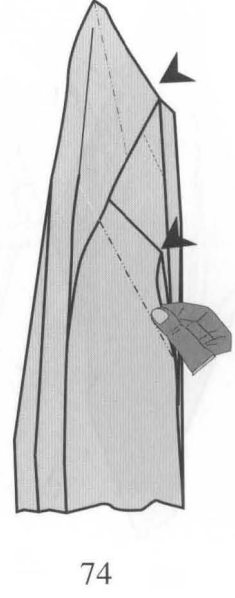
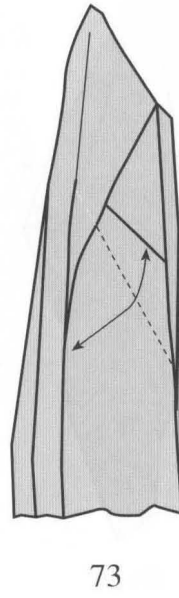
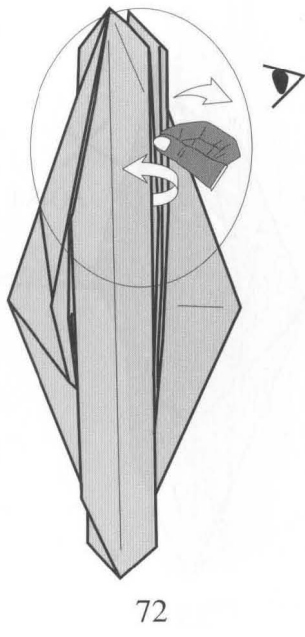
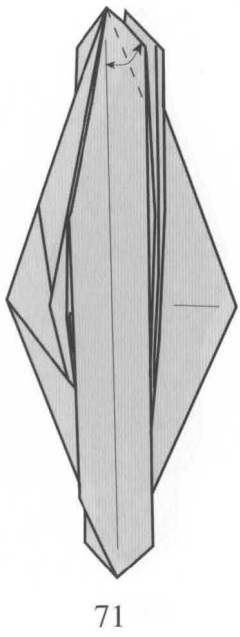
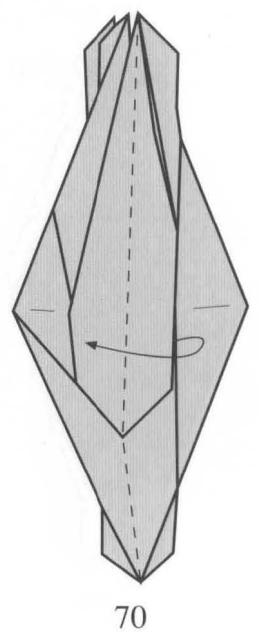
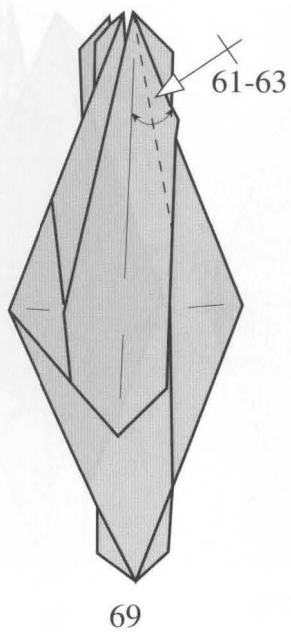
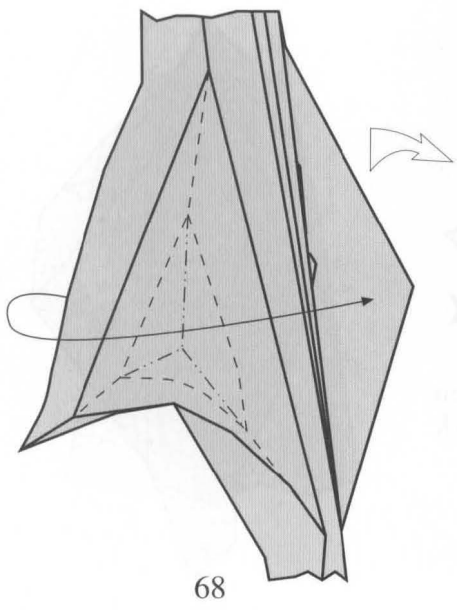

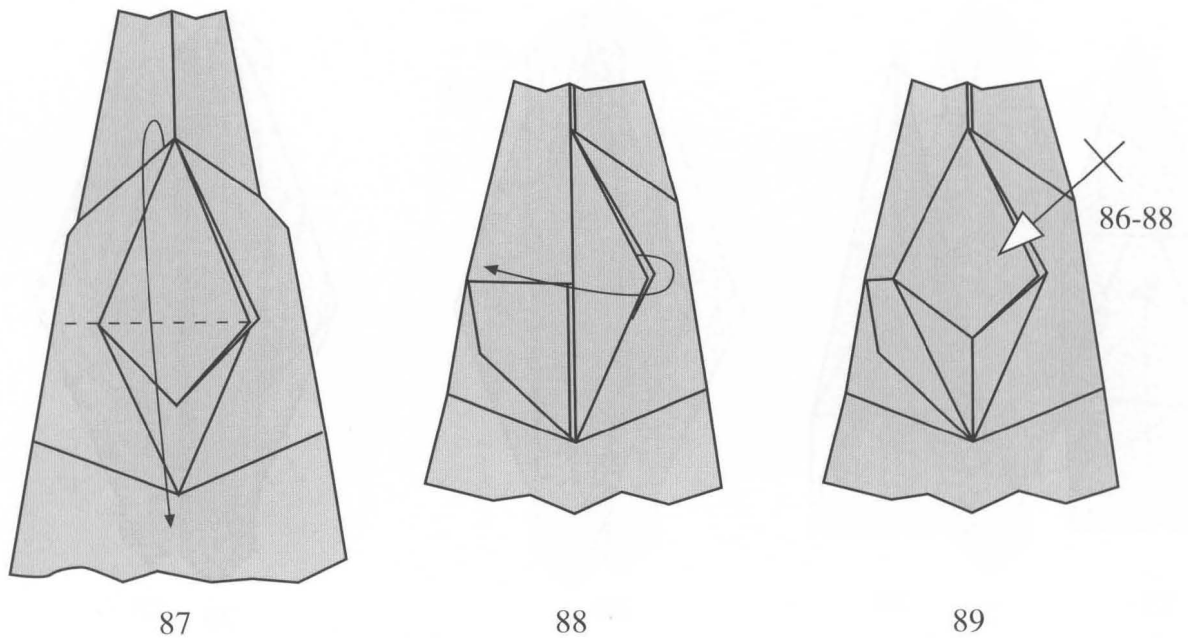
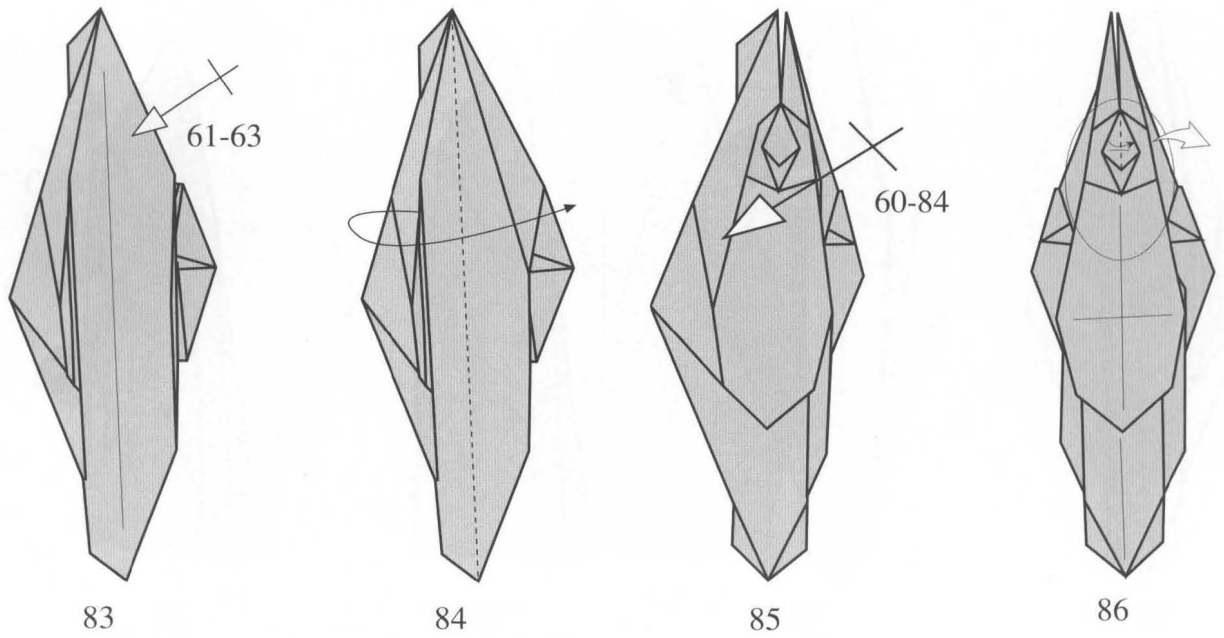
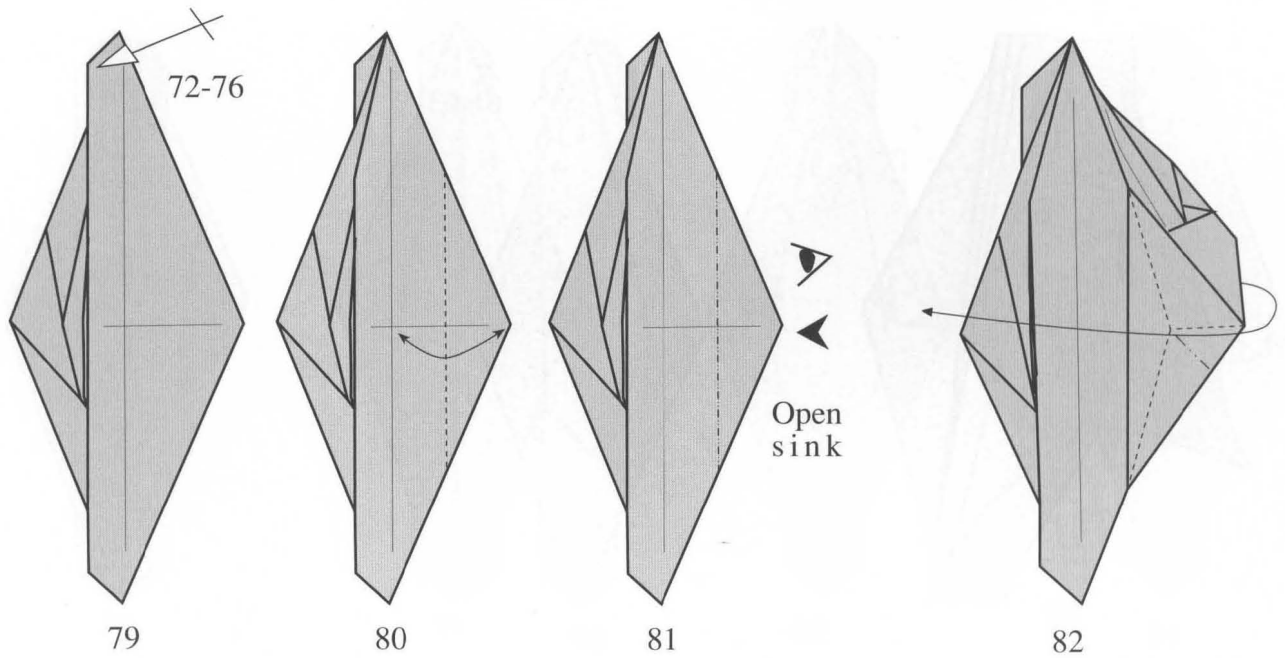

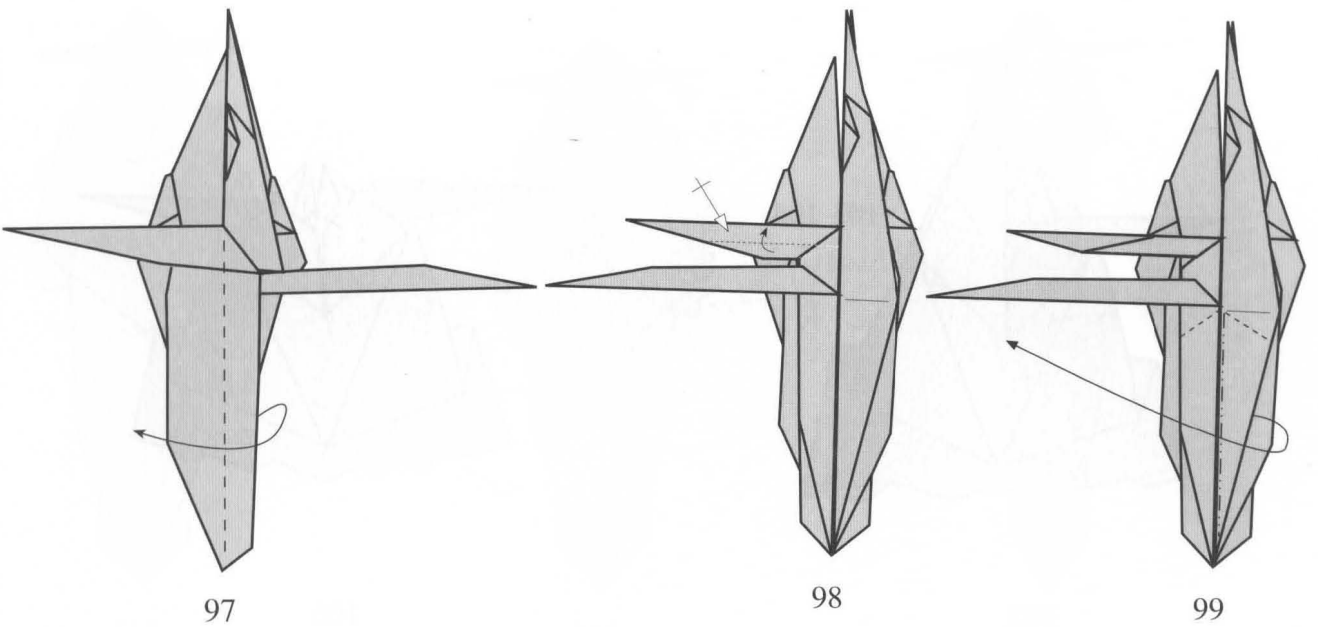
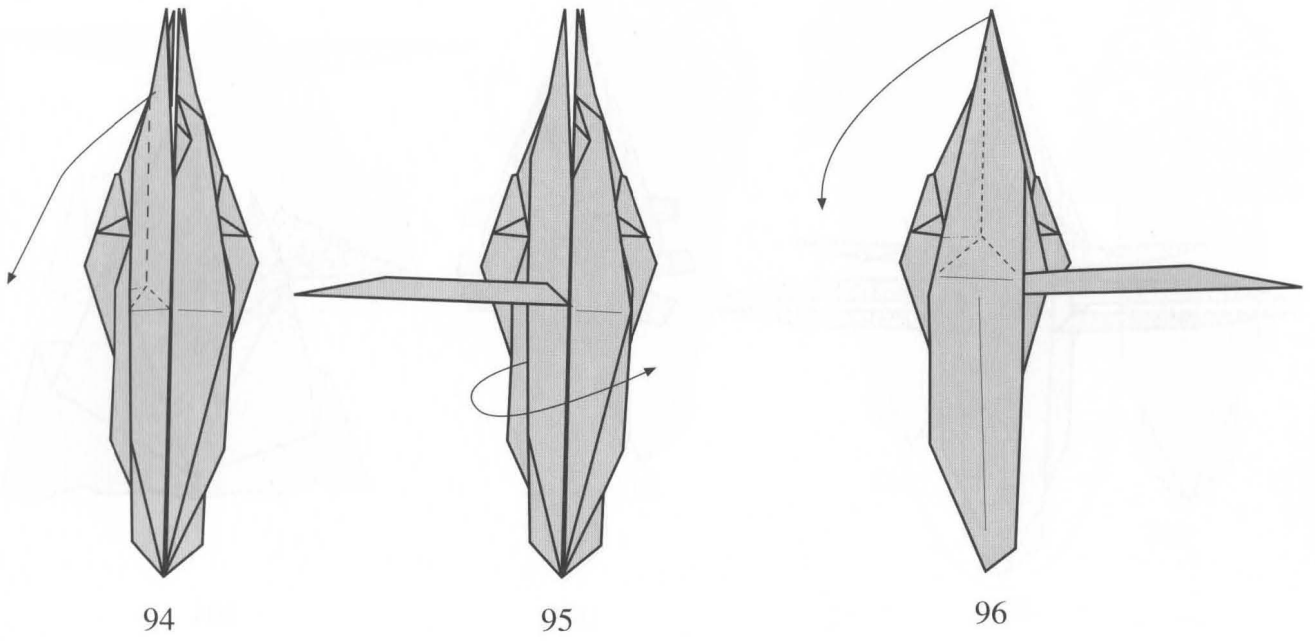
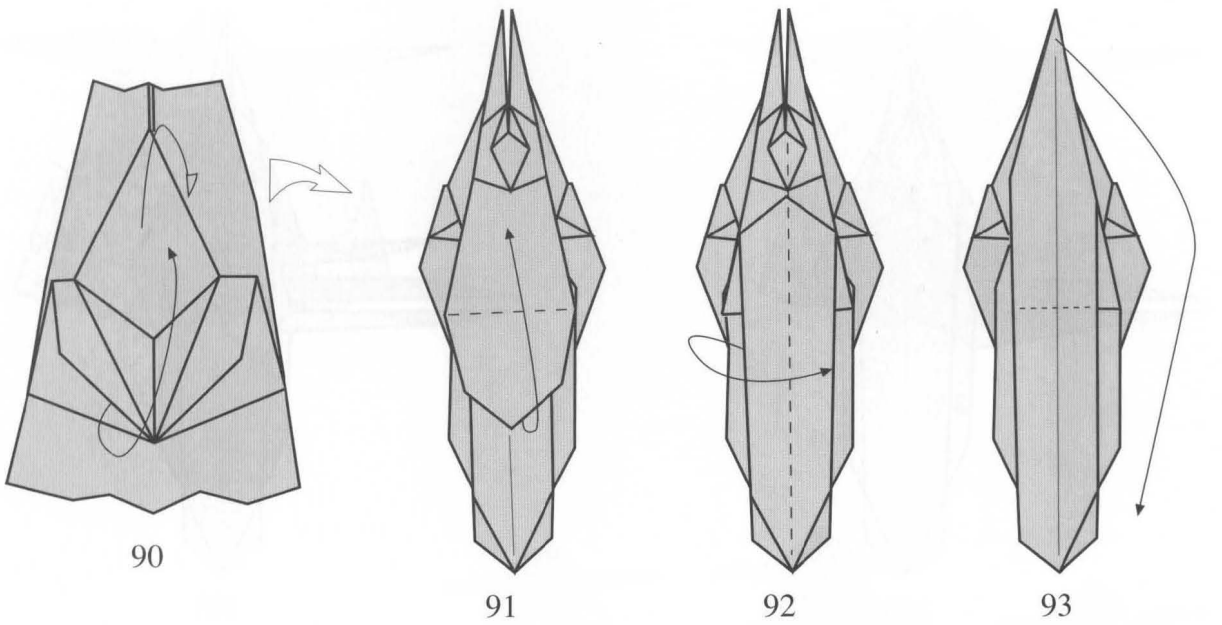

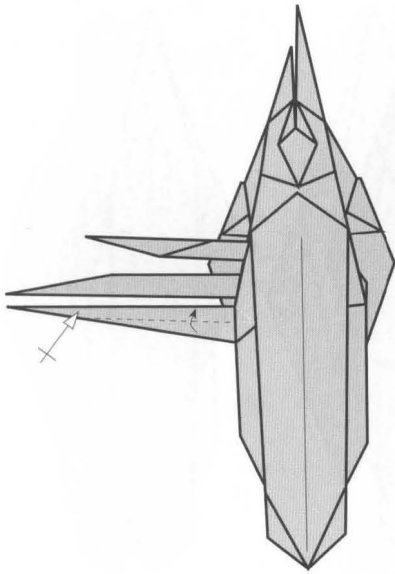

100

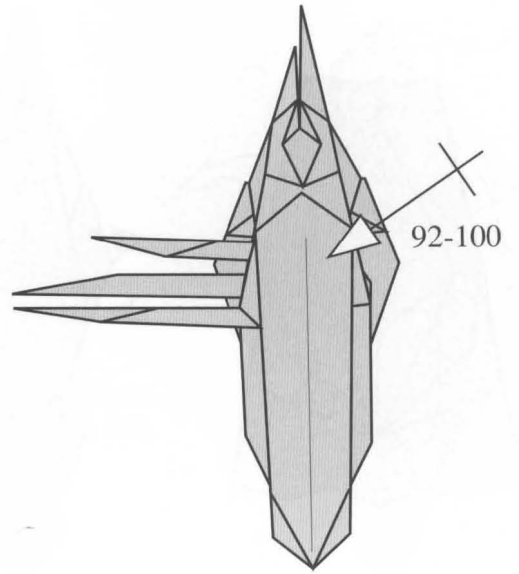

101

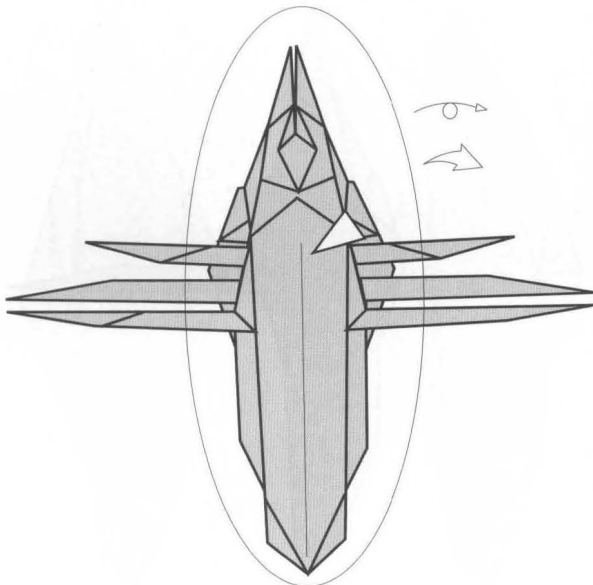

102

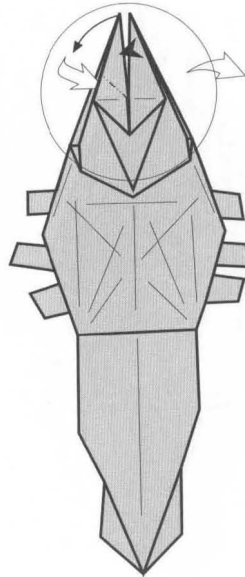

103

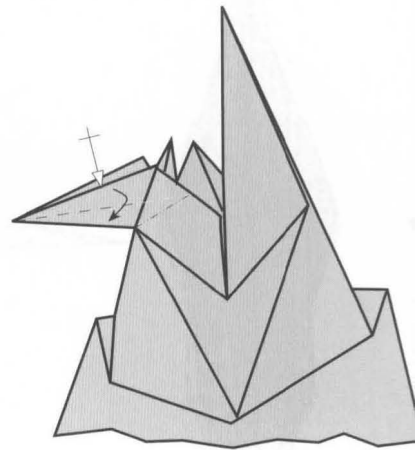

104

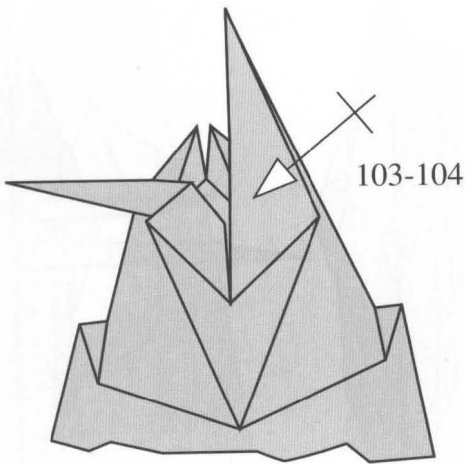

105

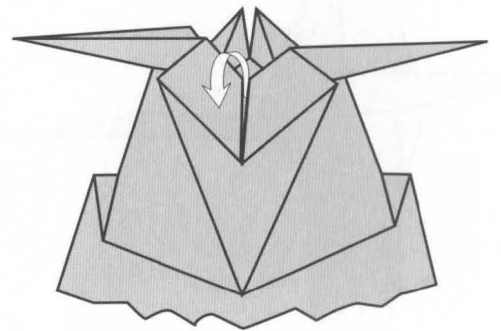

106

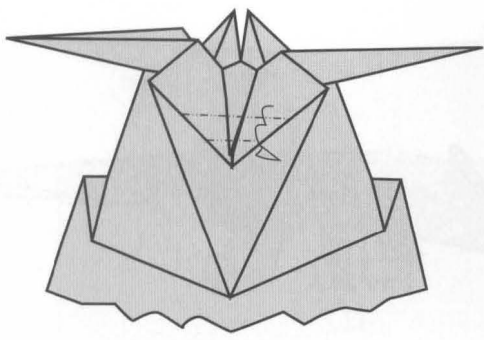

107

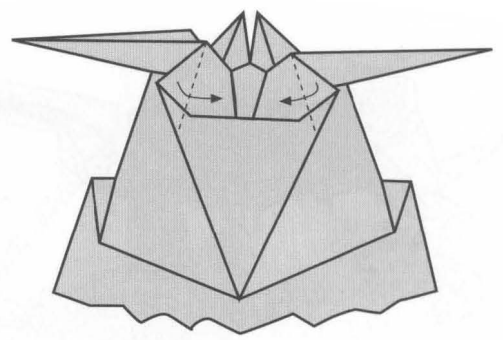

108

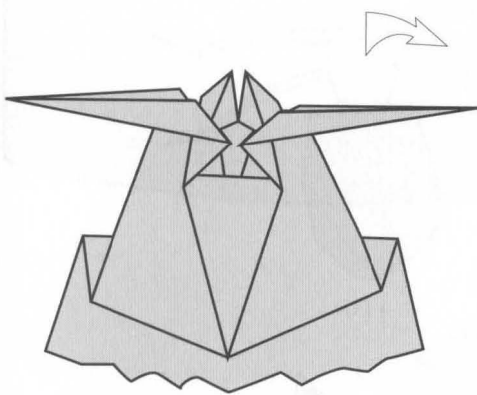

109

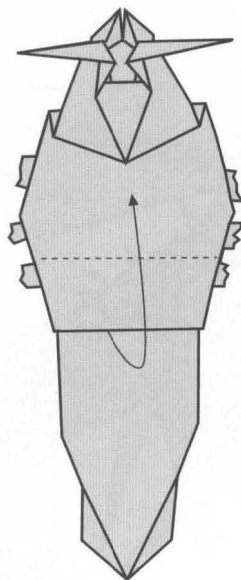

110

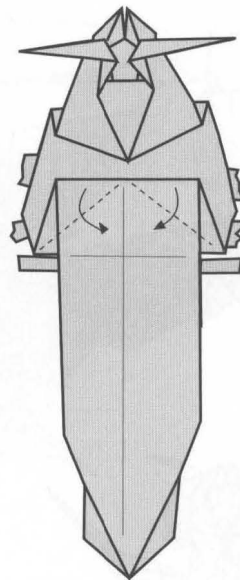

111

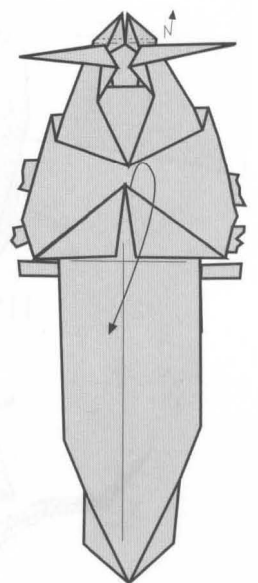

112

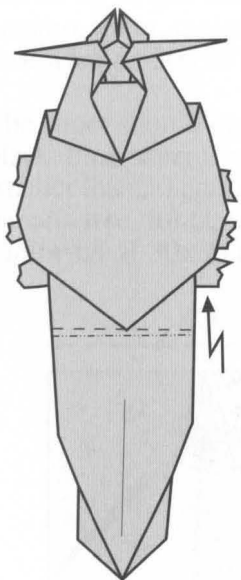

113

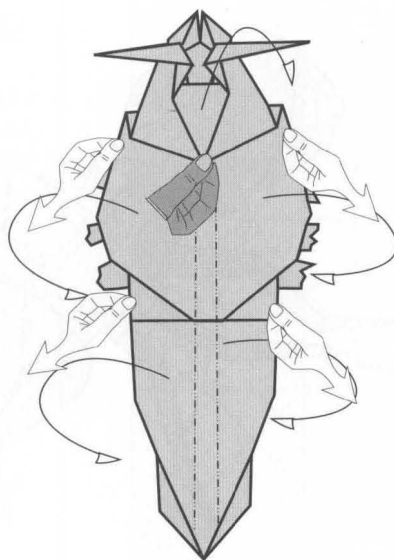

114

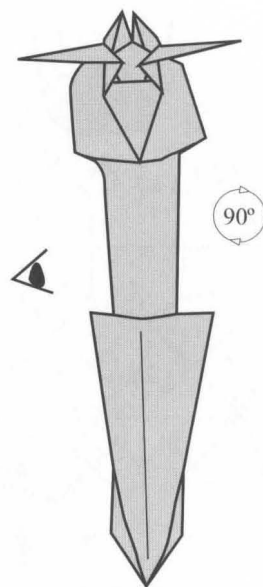

115

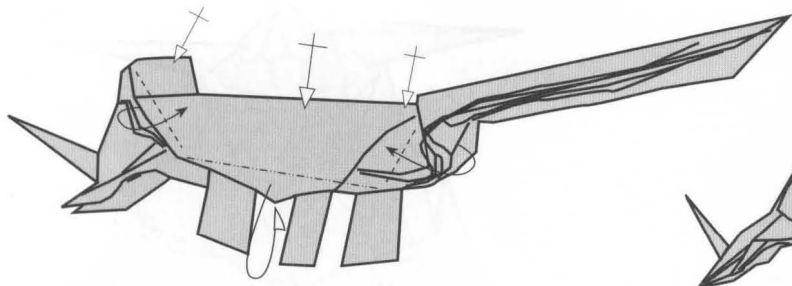

116

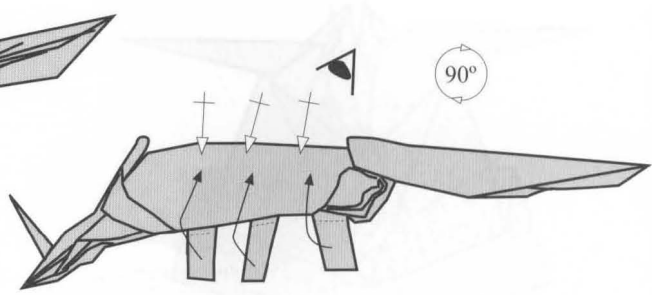

117

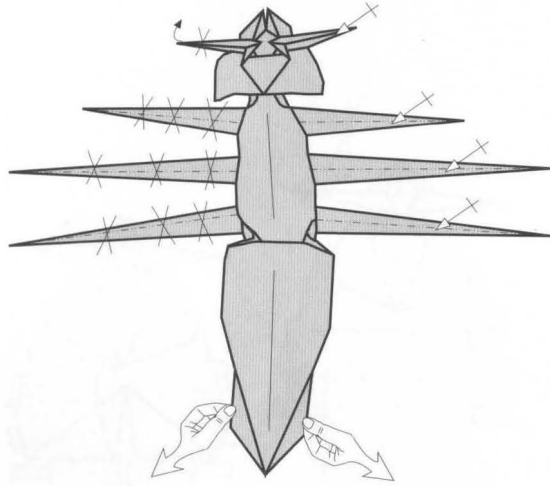

118

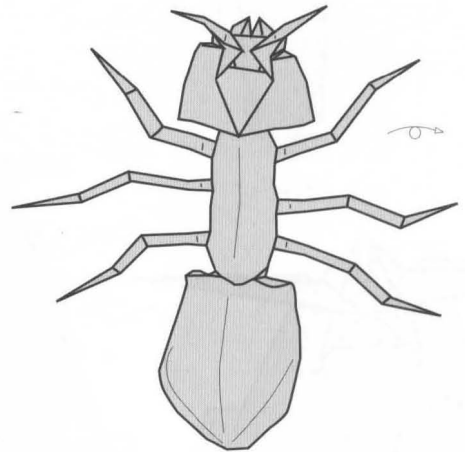

119

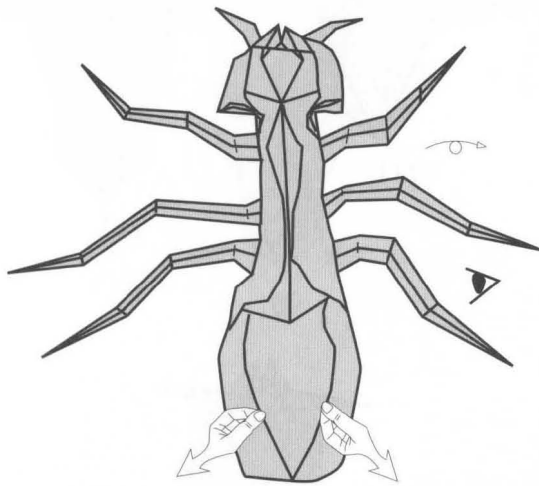

120

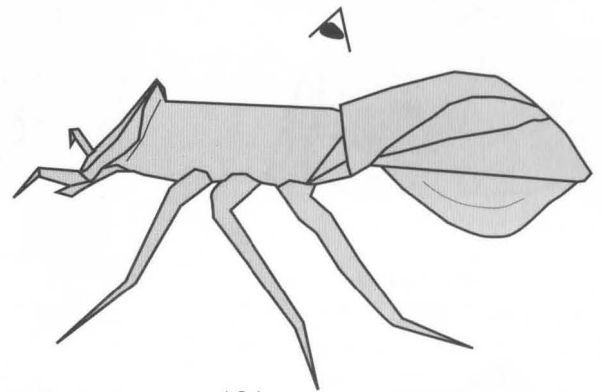

121

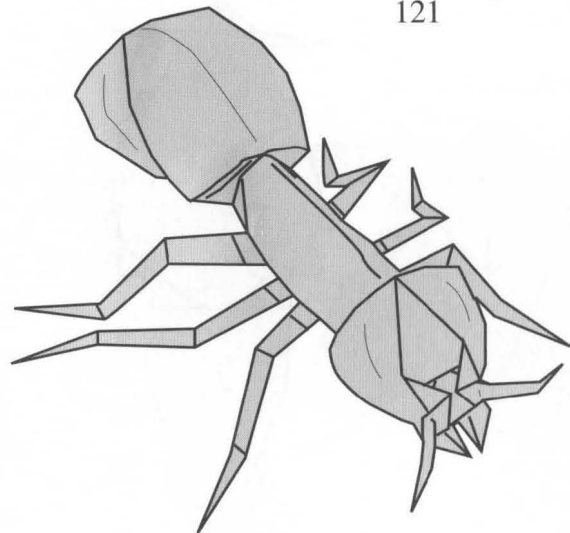

122

Cangrejo de rio

Crayfish

© M. Sirgo - 2002

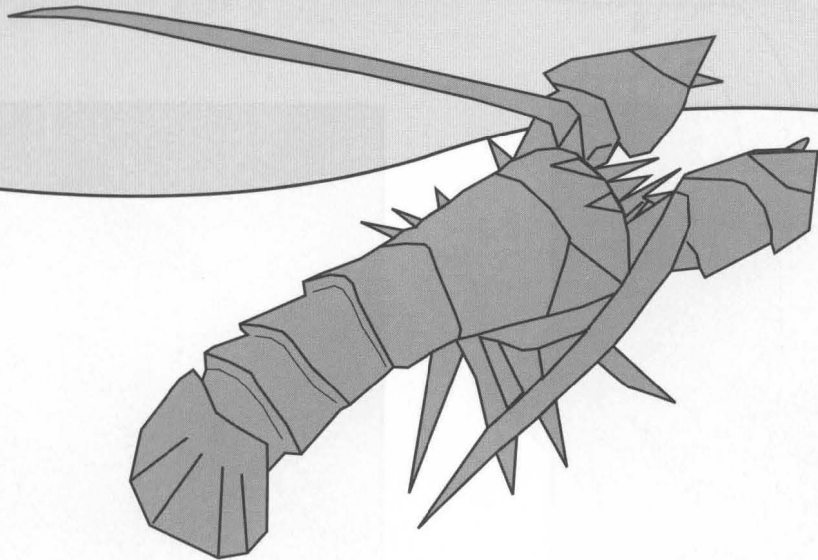
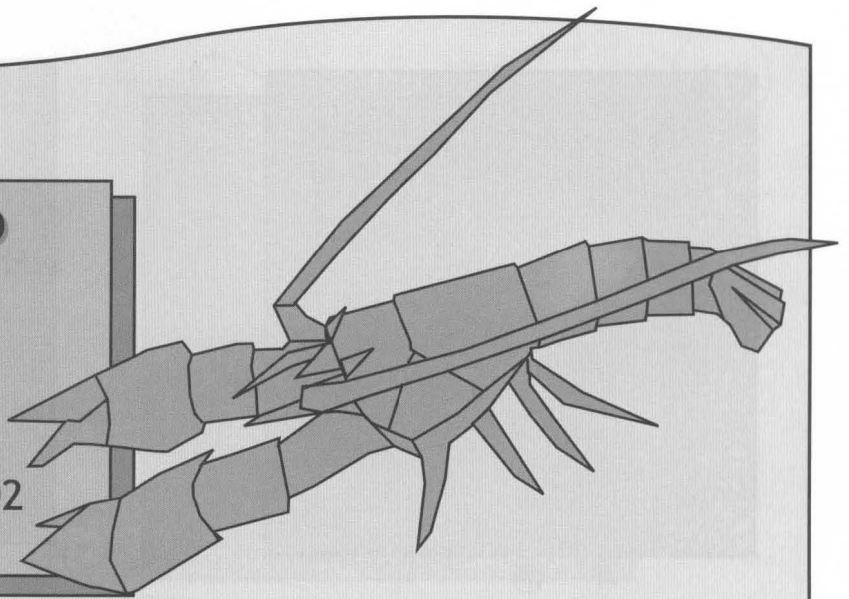

El papel debe ser verde oscuro o negro. Se recomienda papel fino, menor de 30 gramos, doble seda, banano, lokta, metalizado o sandwich de 30x30 cm o mayor.

The paper should be dark green or black. Fine paper is recommended, smaller than 30 grams, double silk, banana tree, lokta, metalized or sandwich of 30x30 cm or bigger.

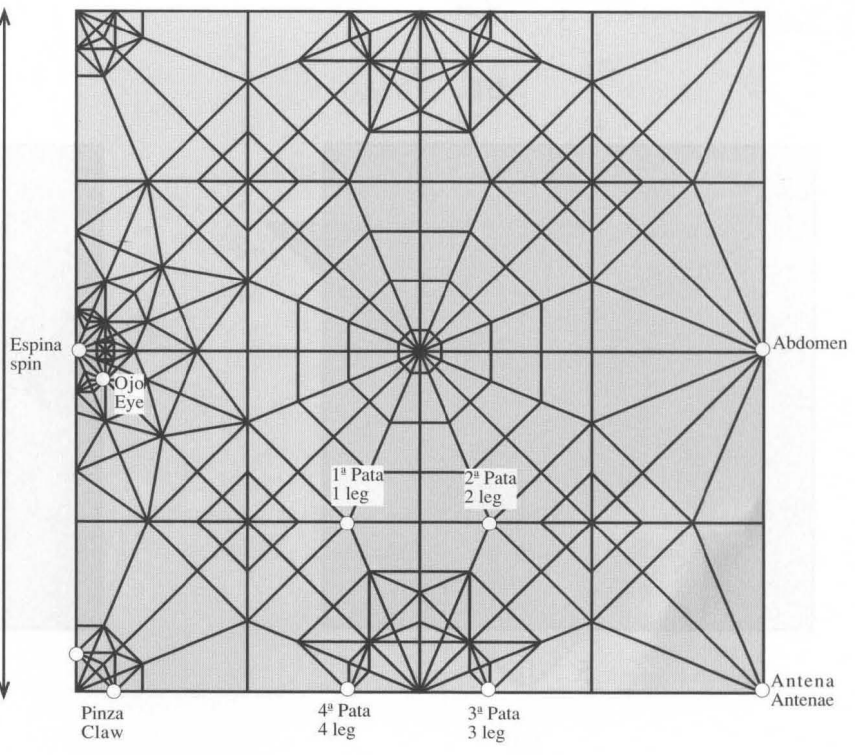
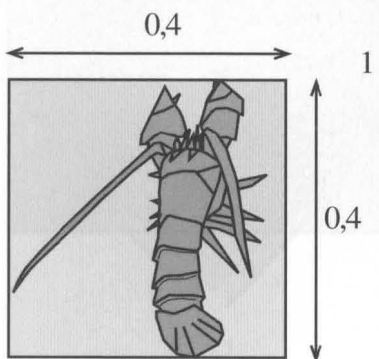

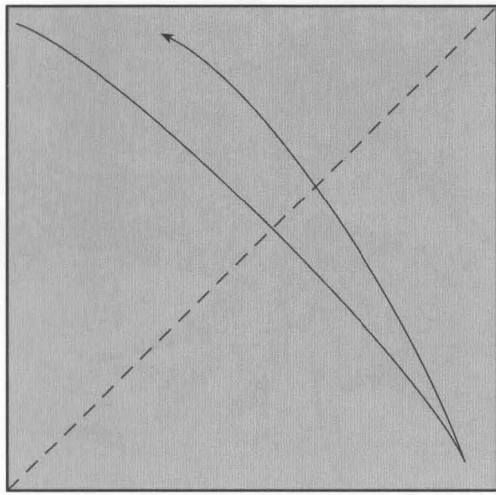

1 ⊖

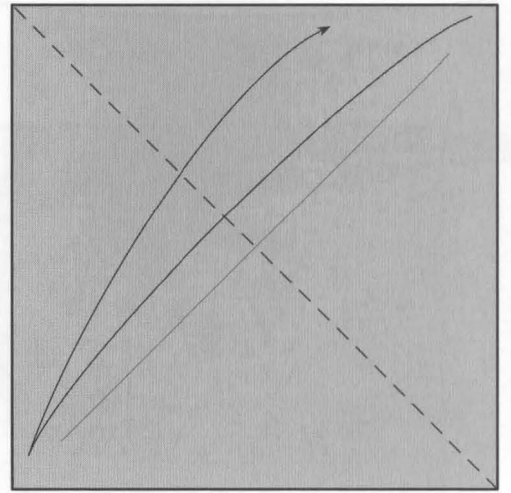

2

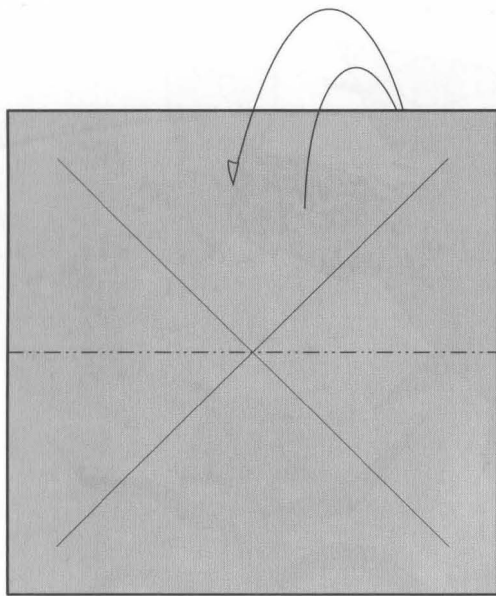

3

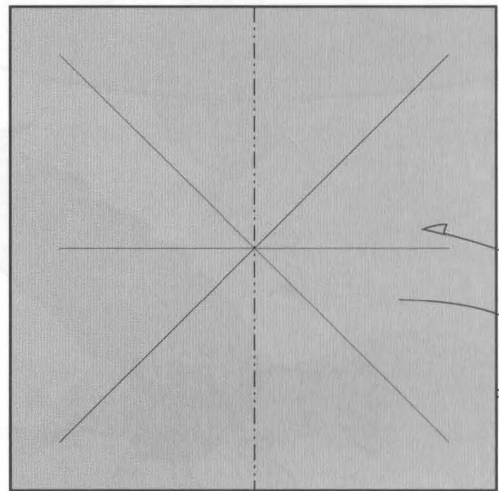

4

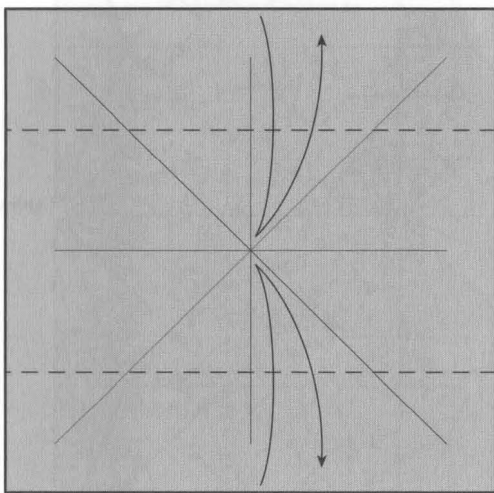

5

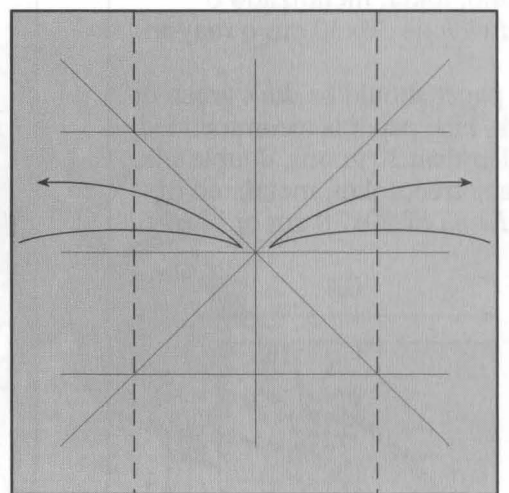

6

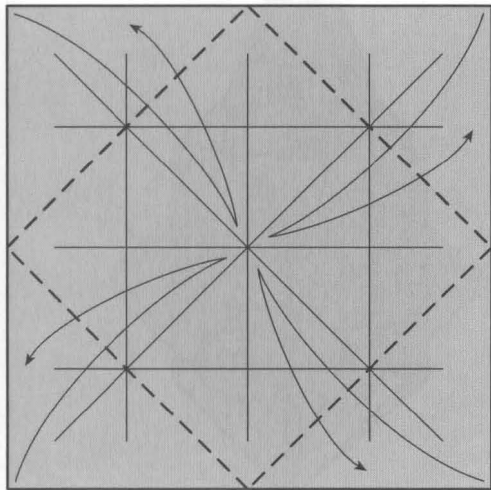

7

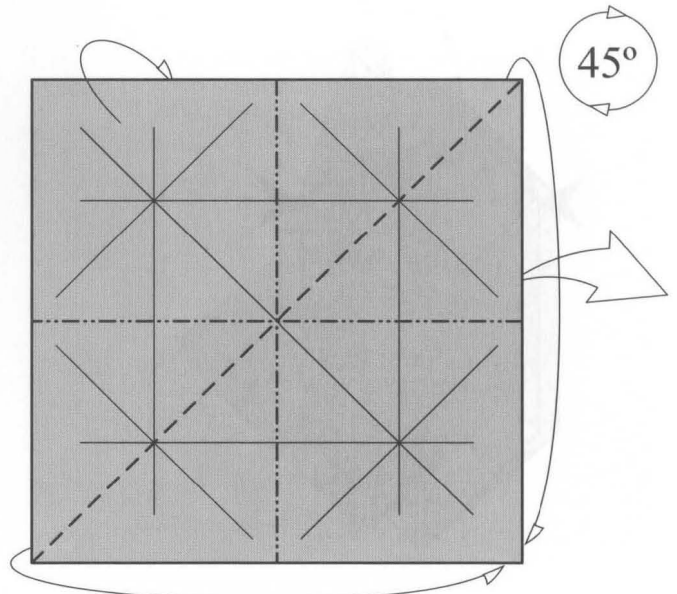

8

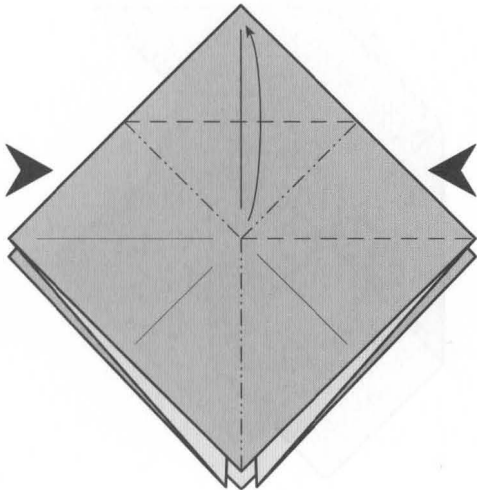

9

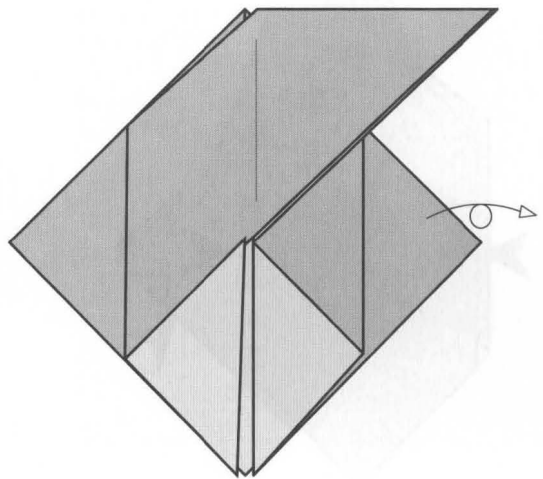

10

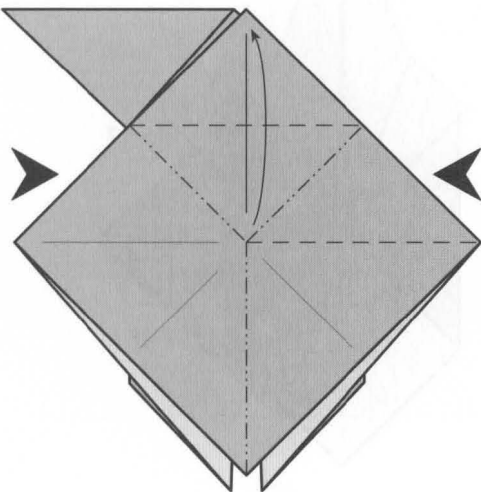

11

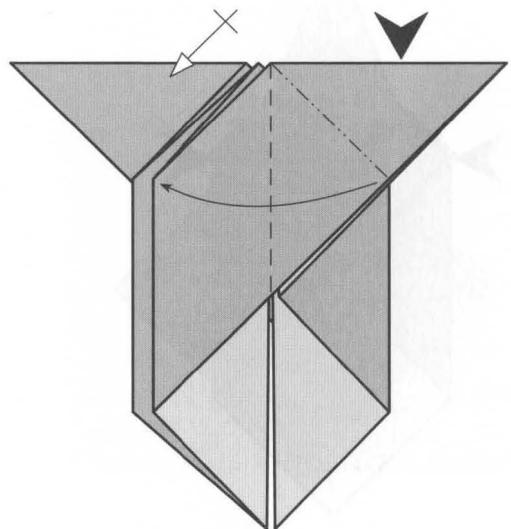

12

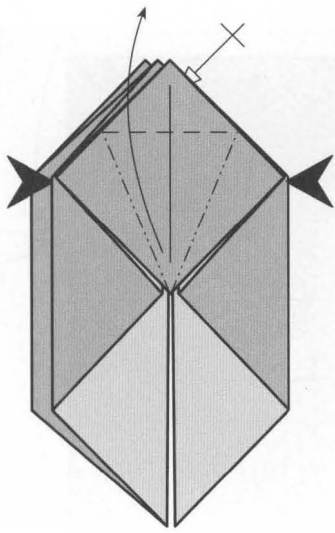

13

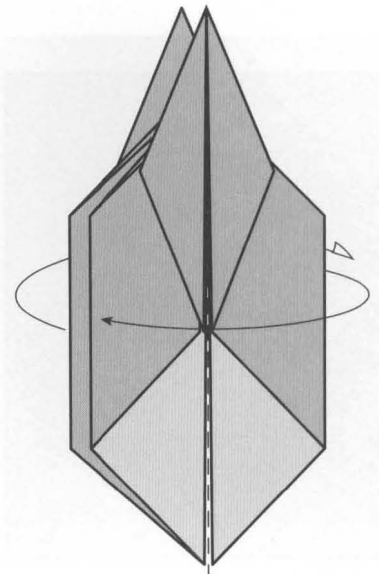

14

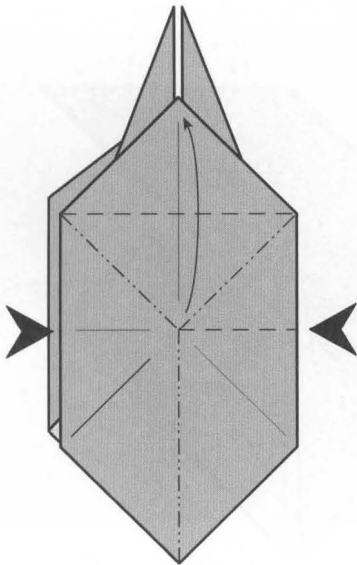

15

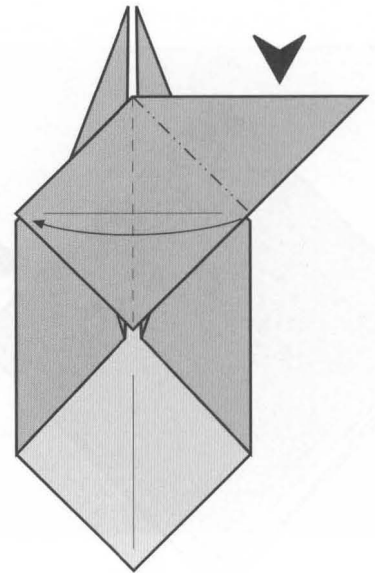

16

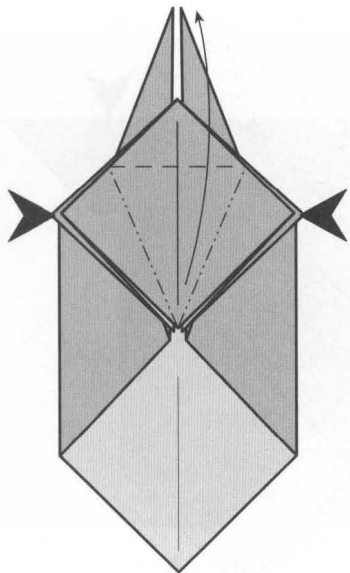

17

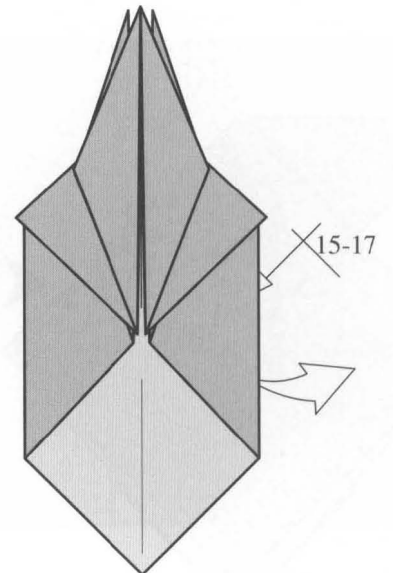

18

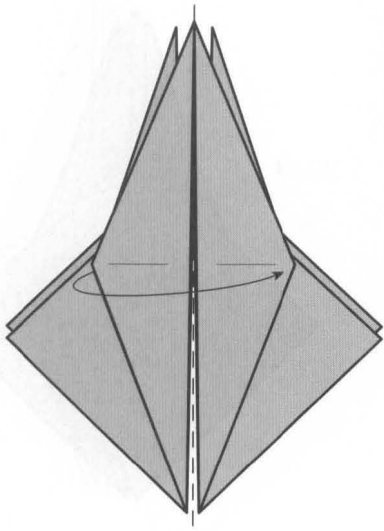

19

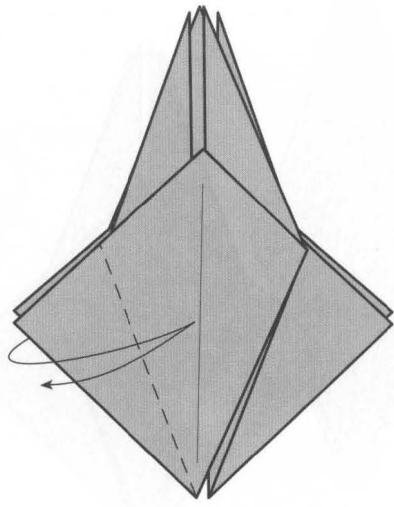

20

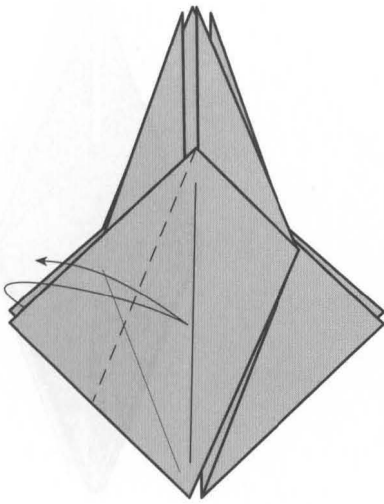

21

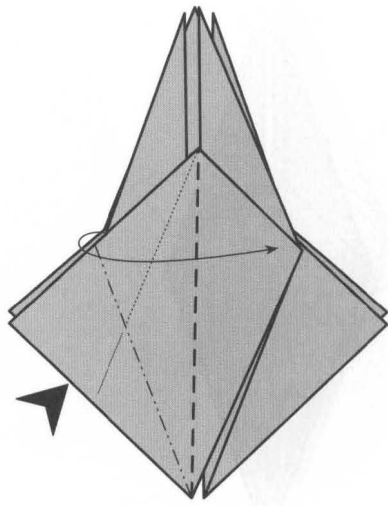

22

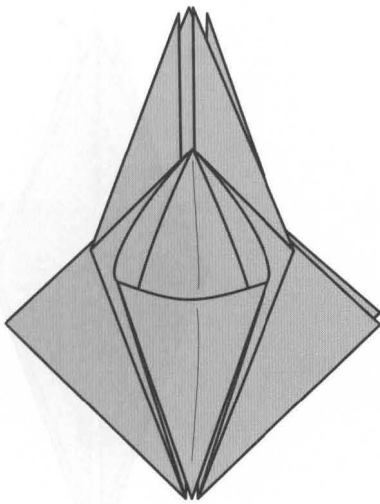

23

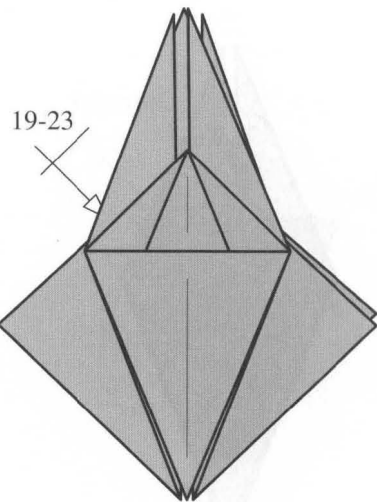

24

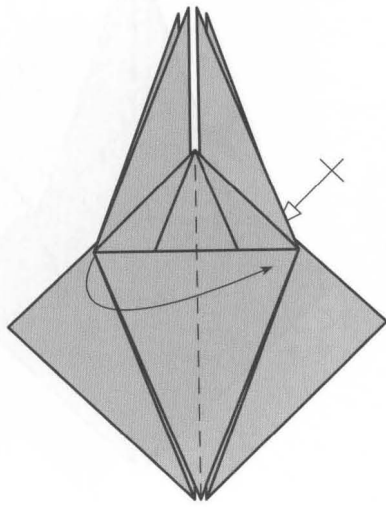

25

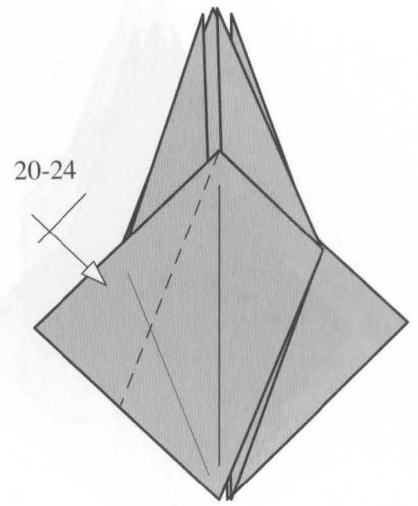

26

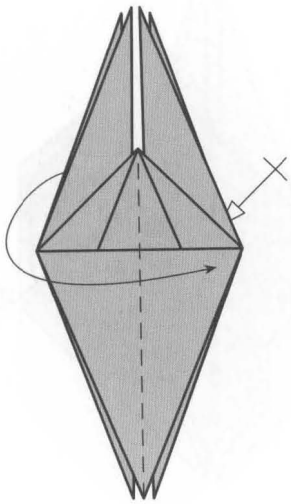

27

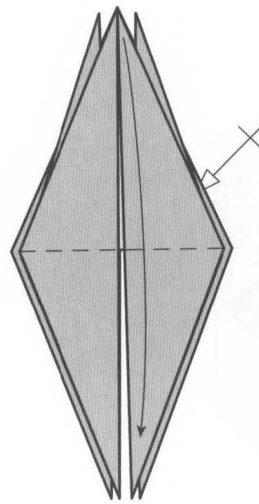

28

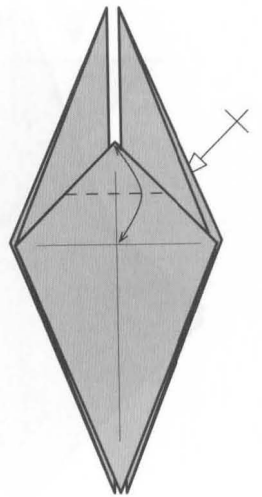

29

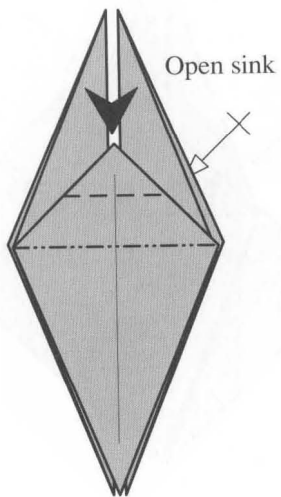

30

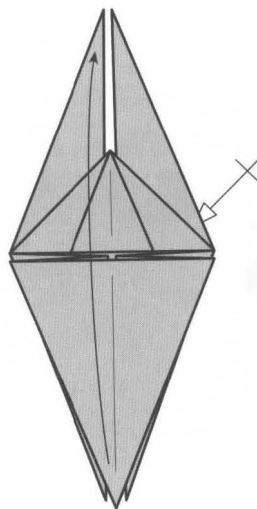

31

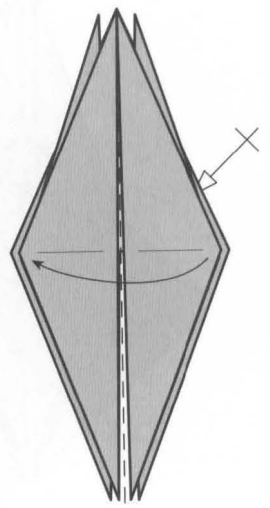

32

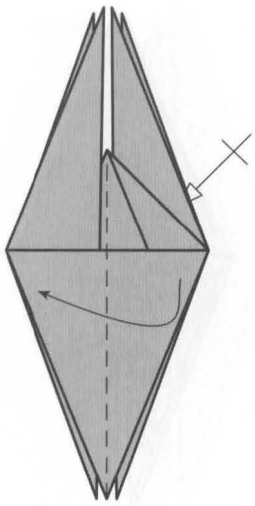

33

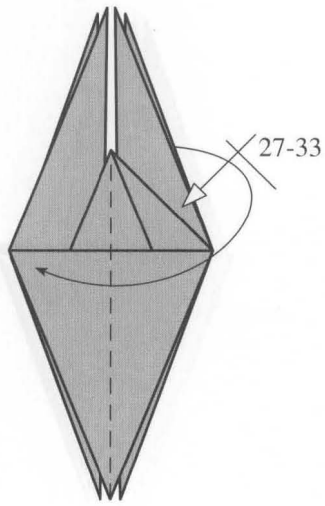

34

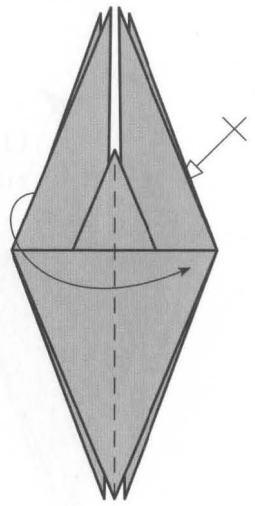

35

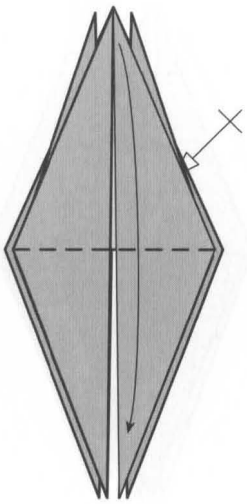

36

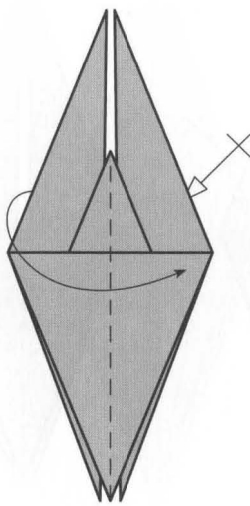

37

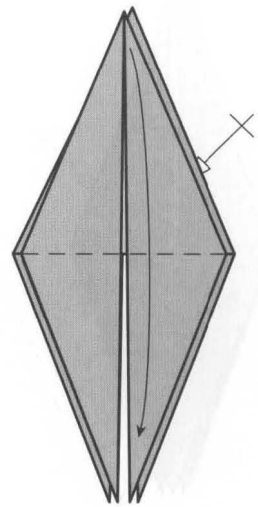

38

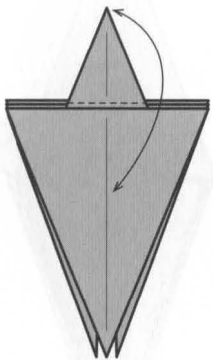

39

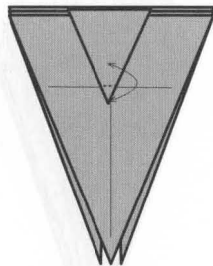

40

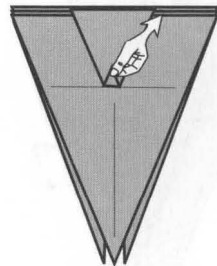

41

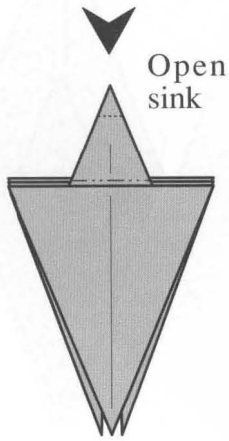

42

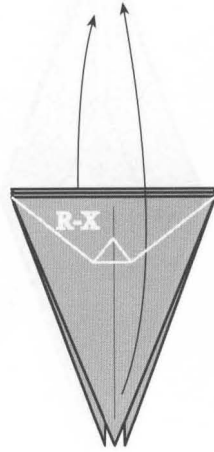

43

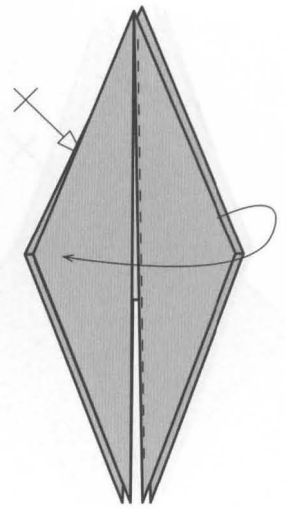

44

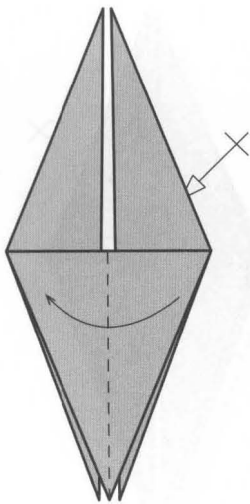

45

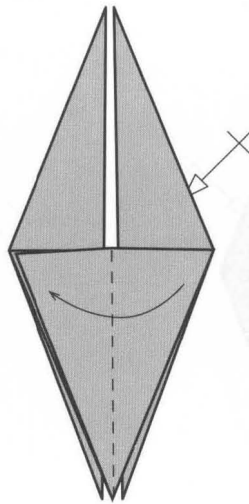

46

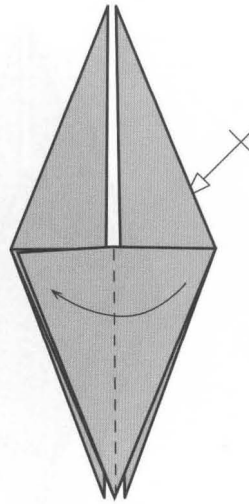

46-A

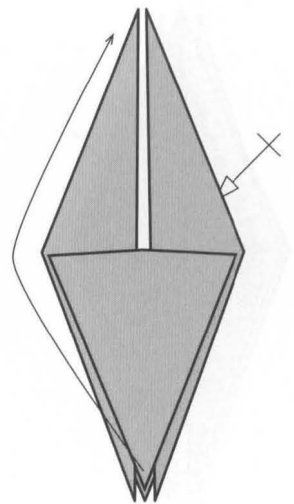

47

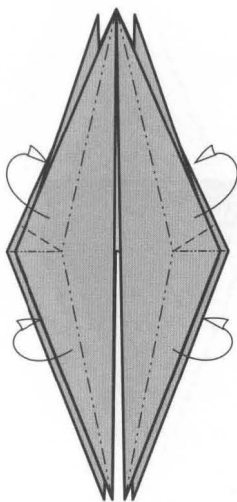

48

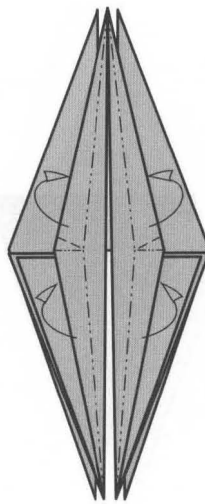

49

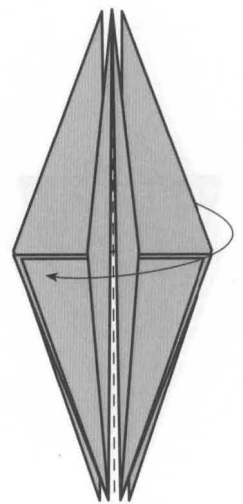

50

48-50

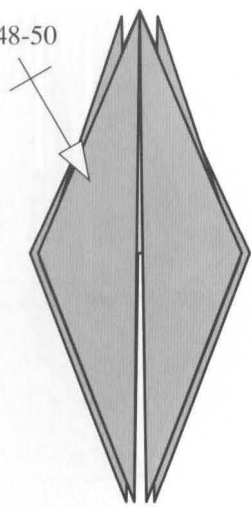

51

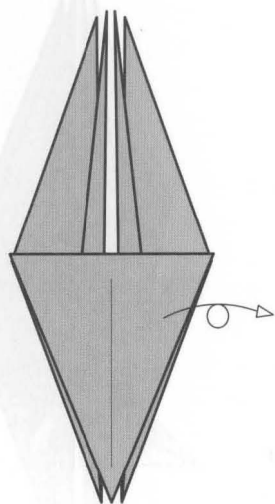

52

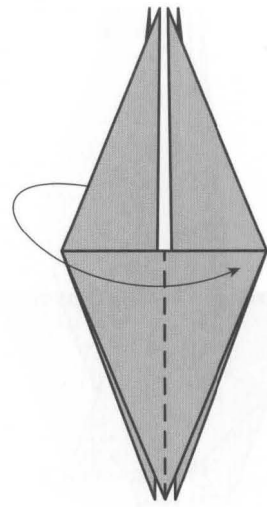

53

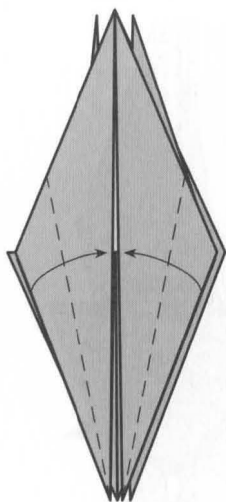

54

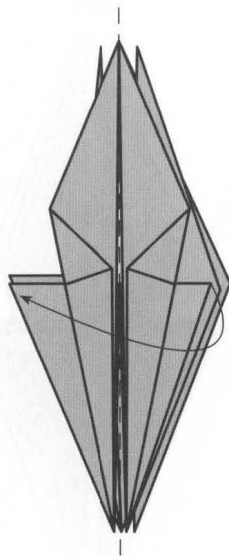

55

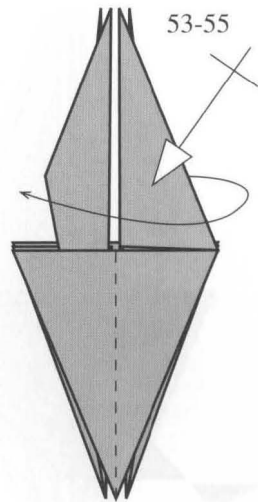

56

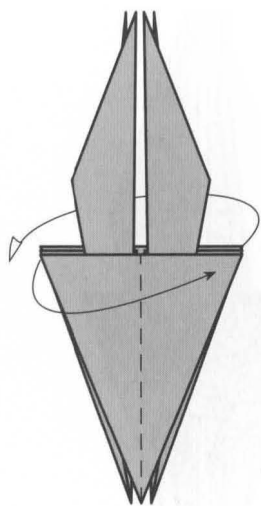

57

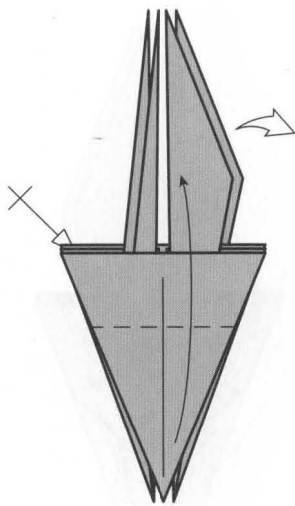

58

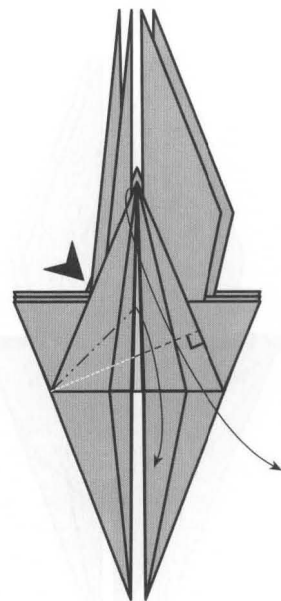

59

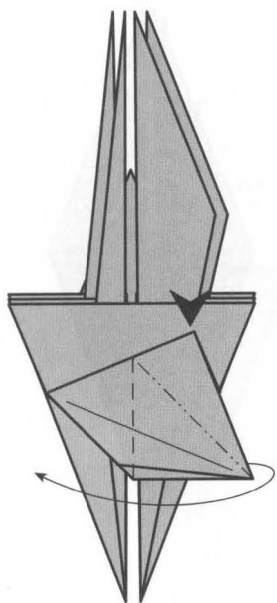

60

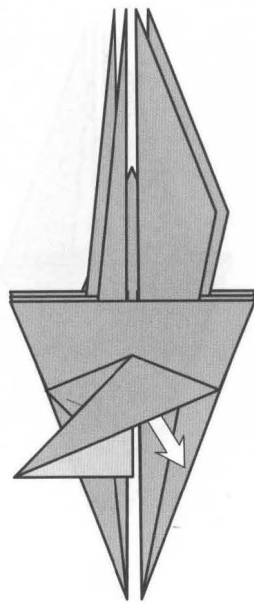

61

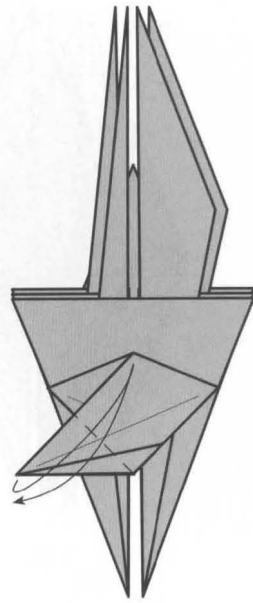

62

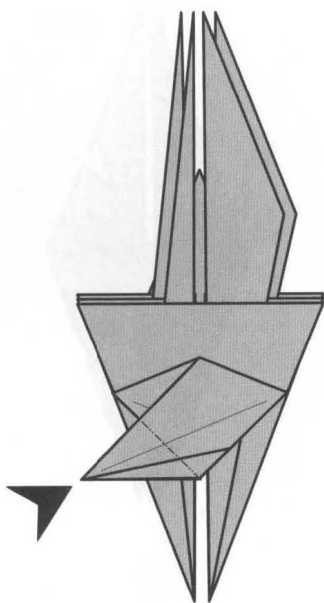

63

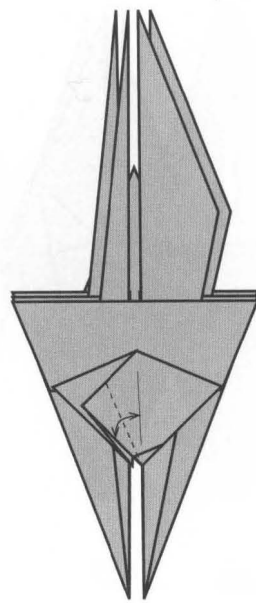

64

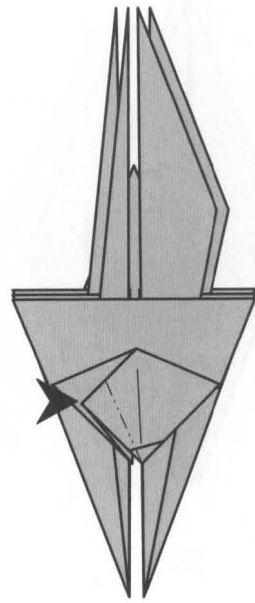

65

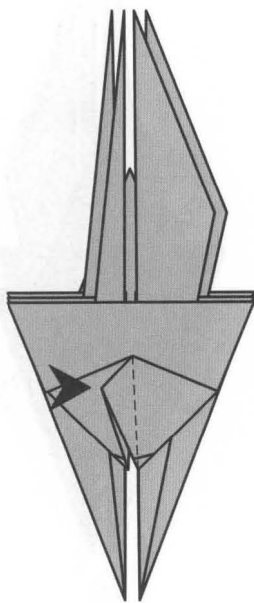

66

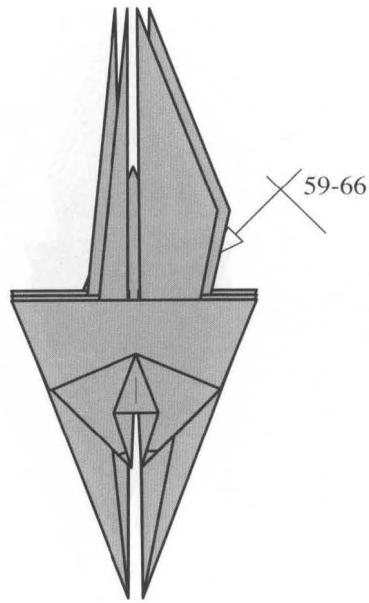

67

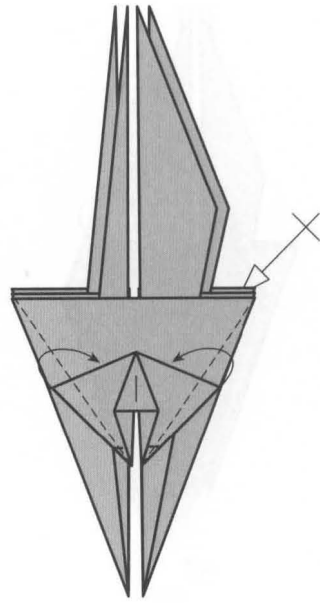

68

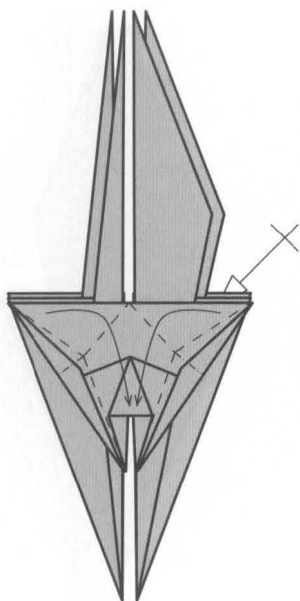

69

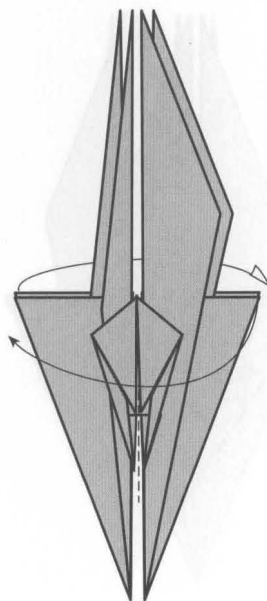

70

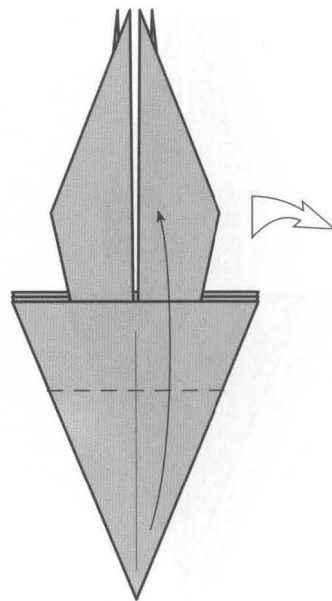

71

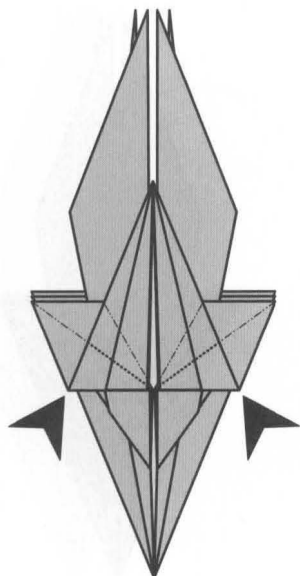

72

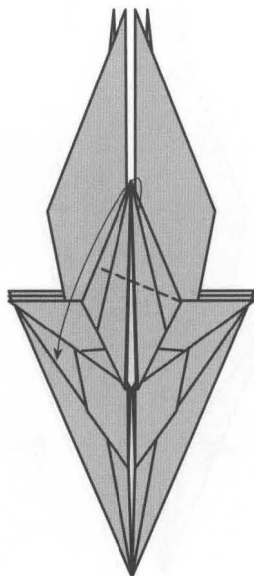

73

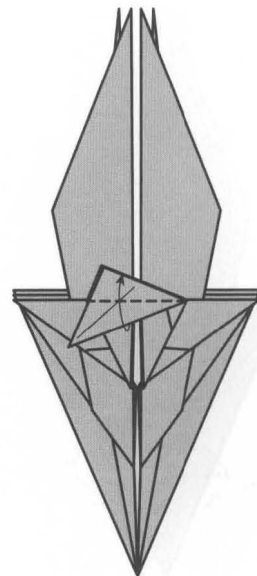

74

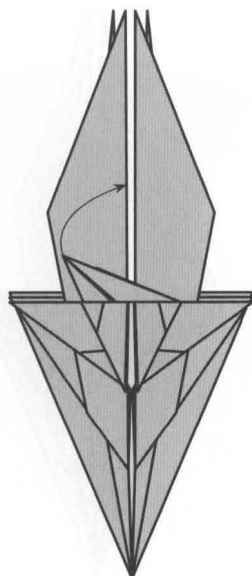

75

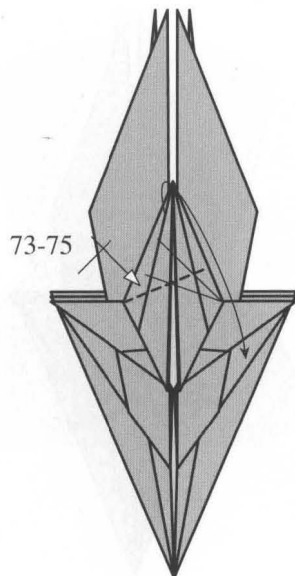

76

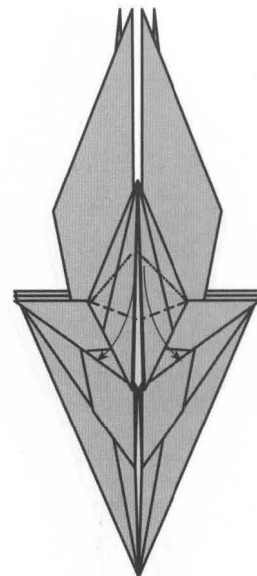

77

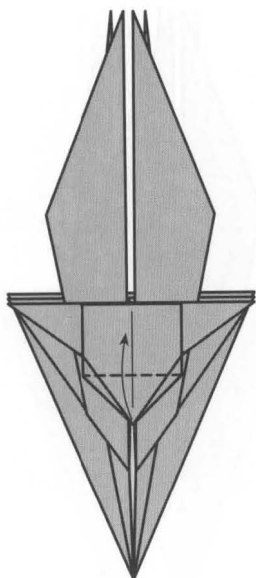

78

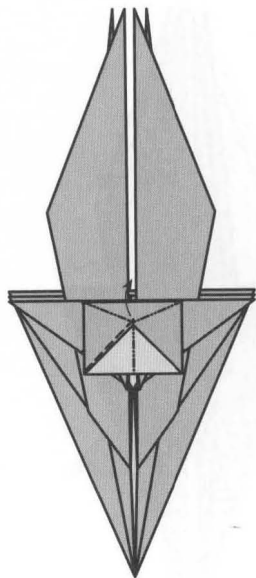

79

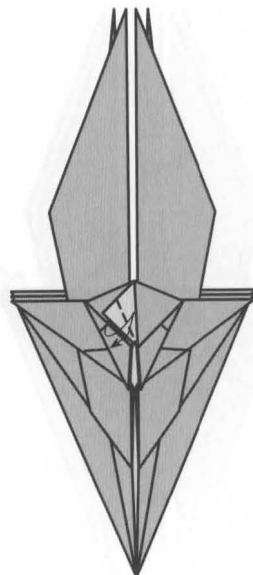

80

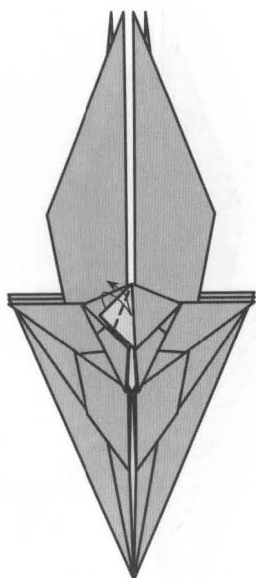

81

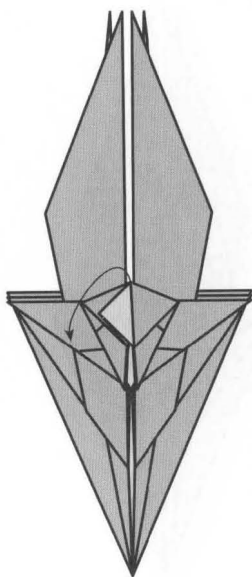

82

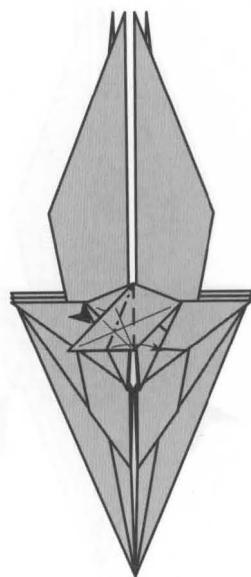

83

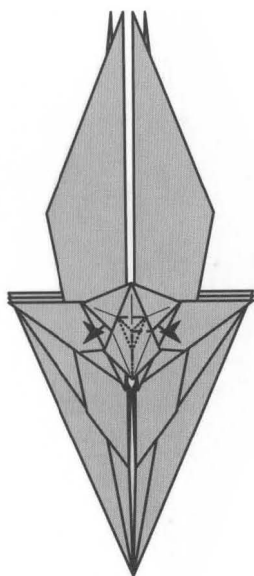

84

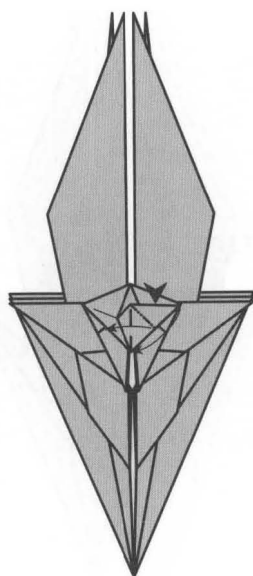

85

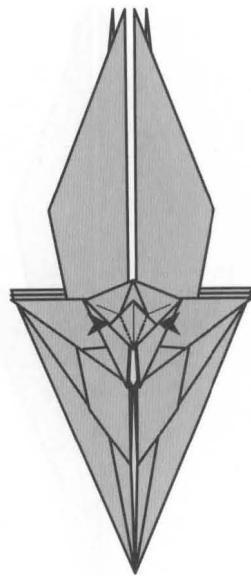

86

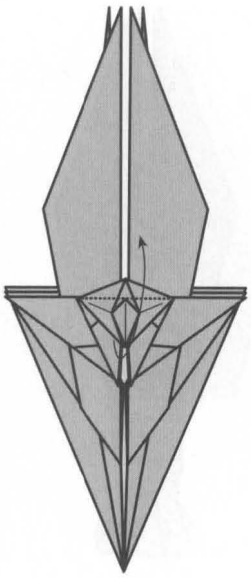

87

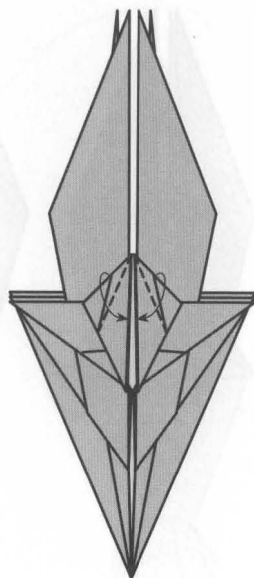

88

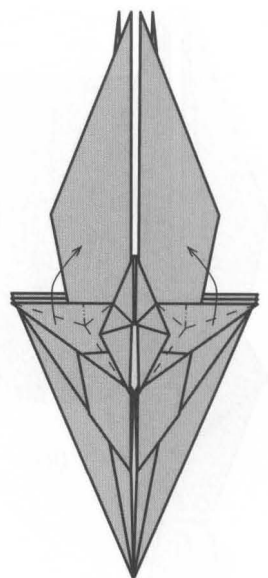

89

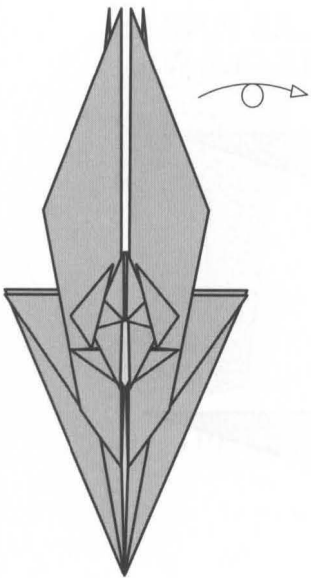

90

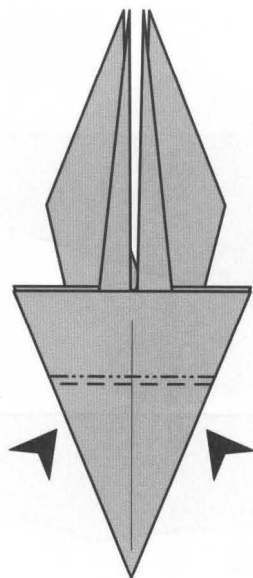

91

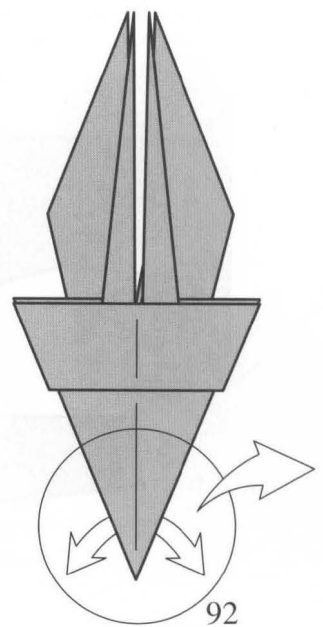

92

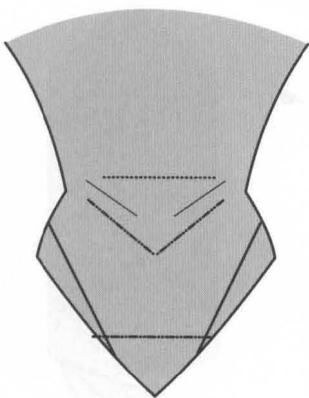

93

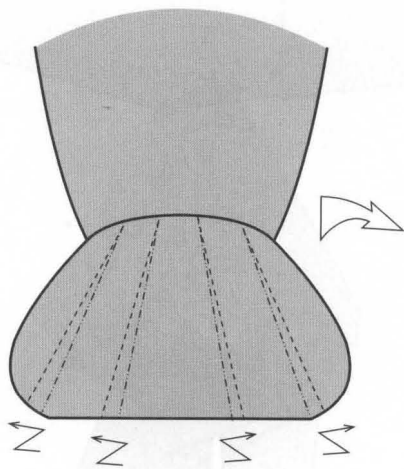

94

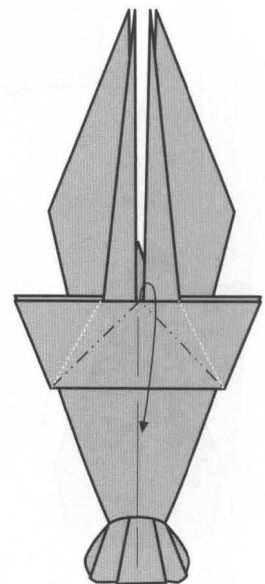

95

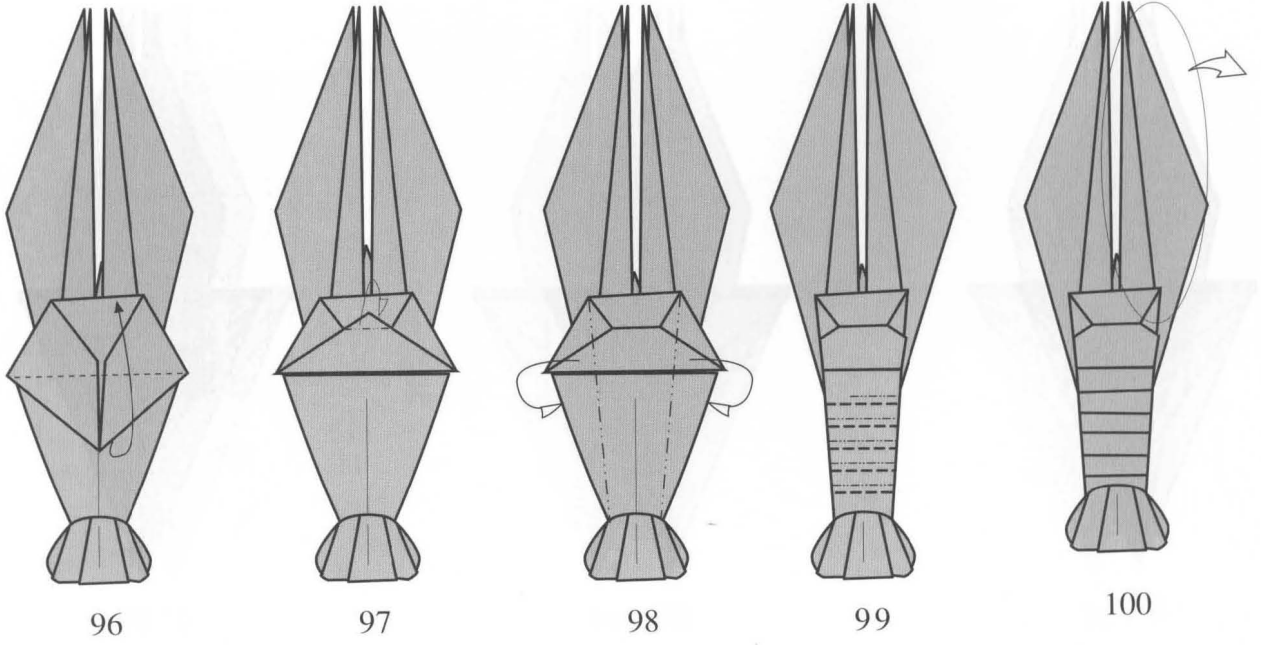

PLEGADO DE LAS PINZAS
 FOLDED OF THE CLAWS

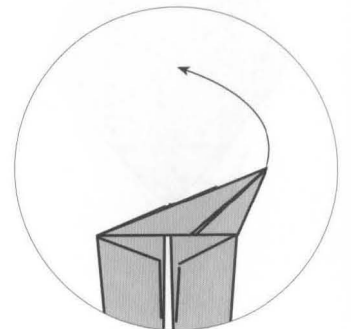
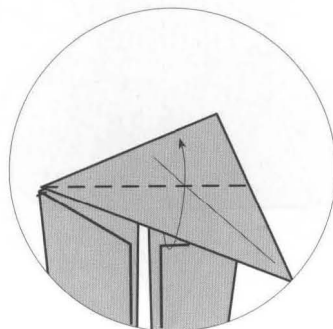
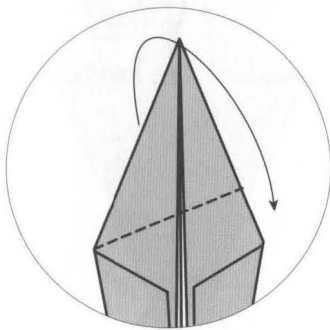
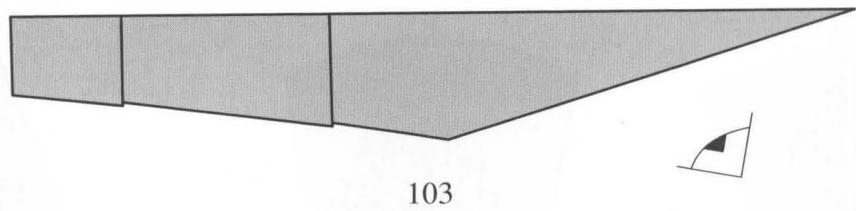
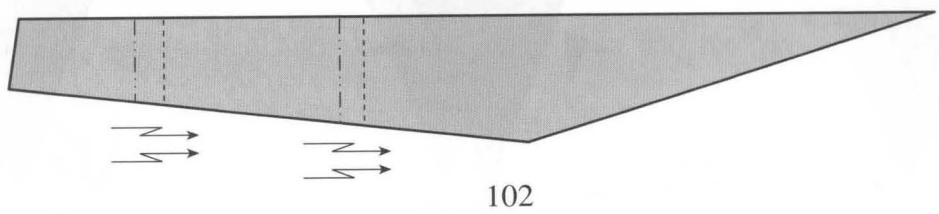
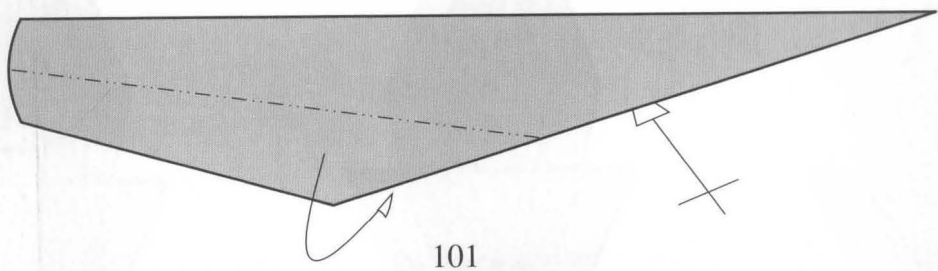

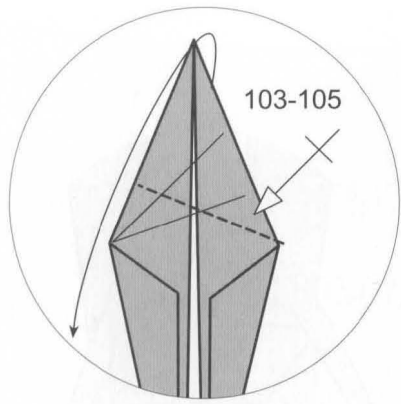

107

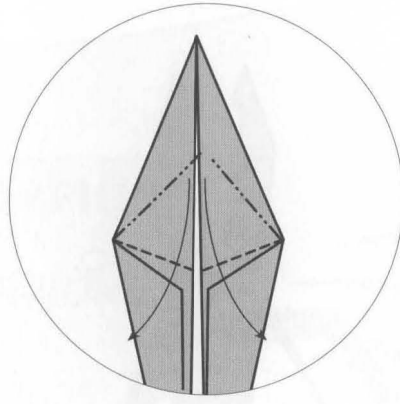

108

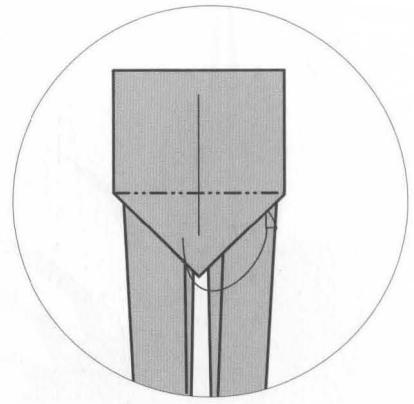

109

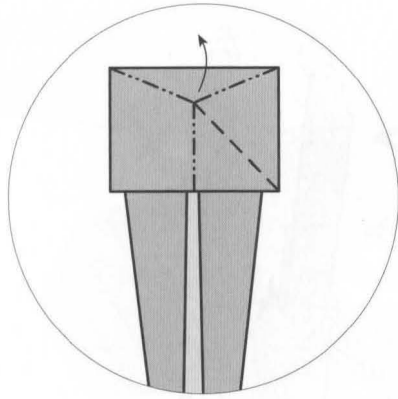

110

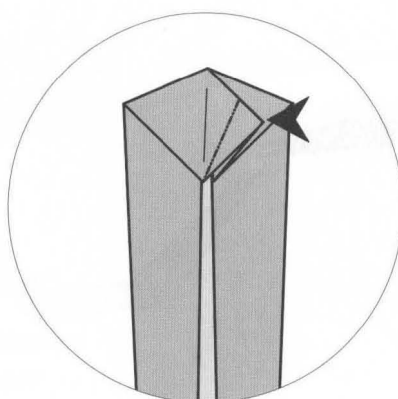

111

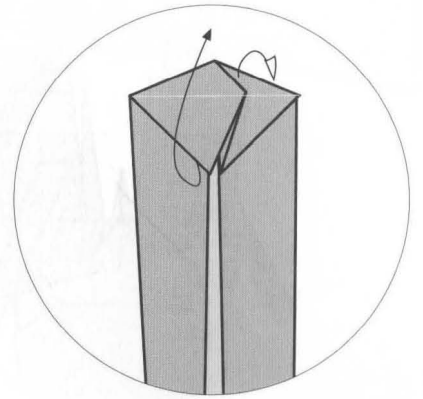

112

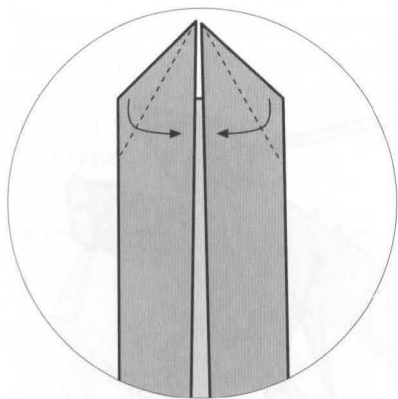

113

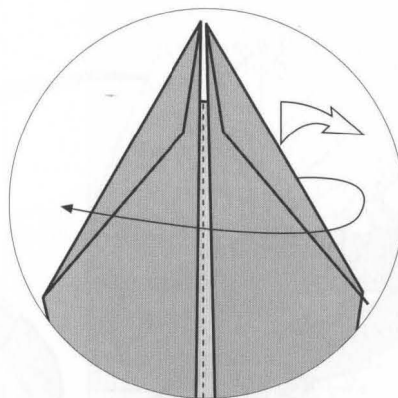

114

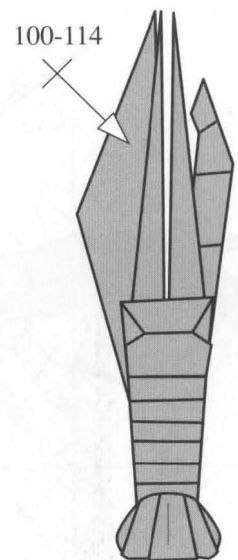

115

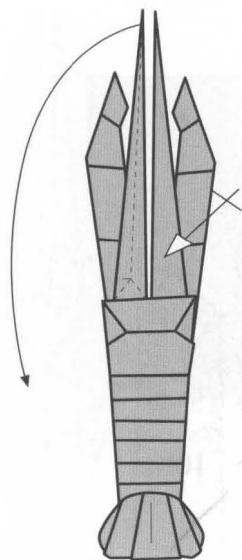

116

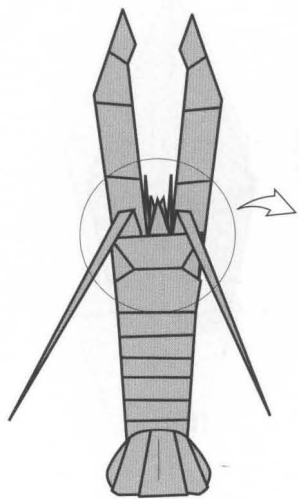

117

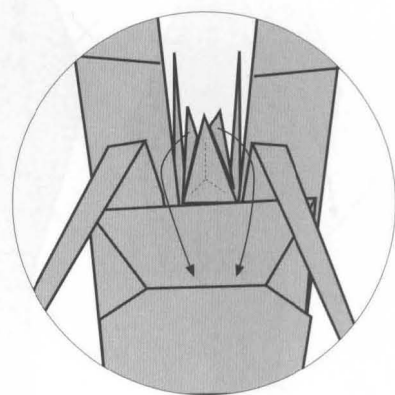

118

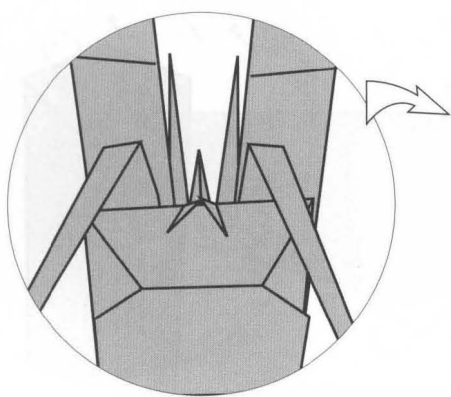

119

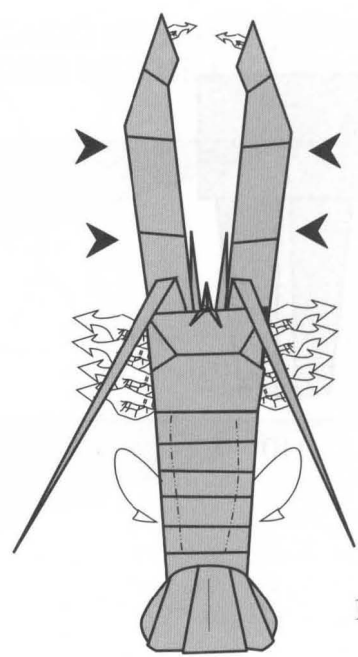

120

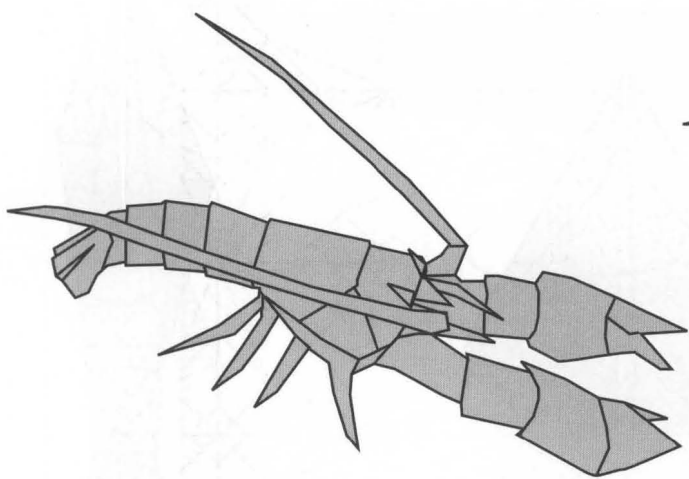

121

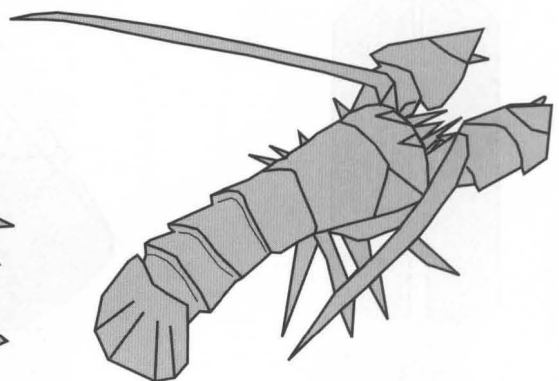

180

PSEUDOESCORPIÓN

PSEUDOSCORPION

© M. Sirgo - 2005

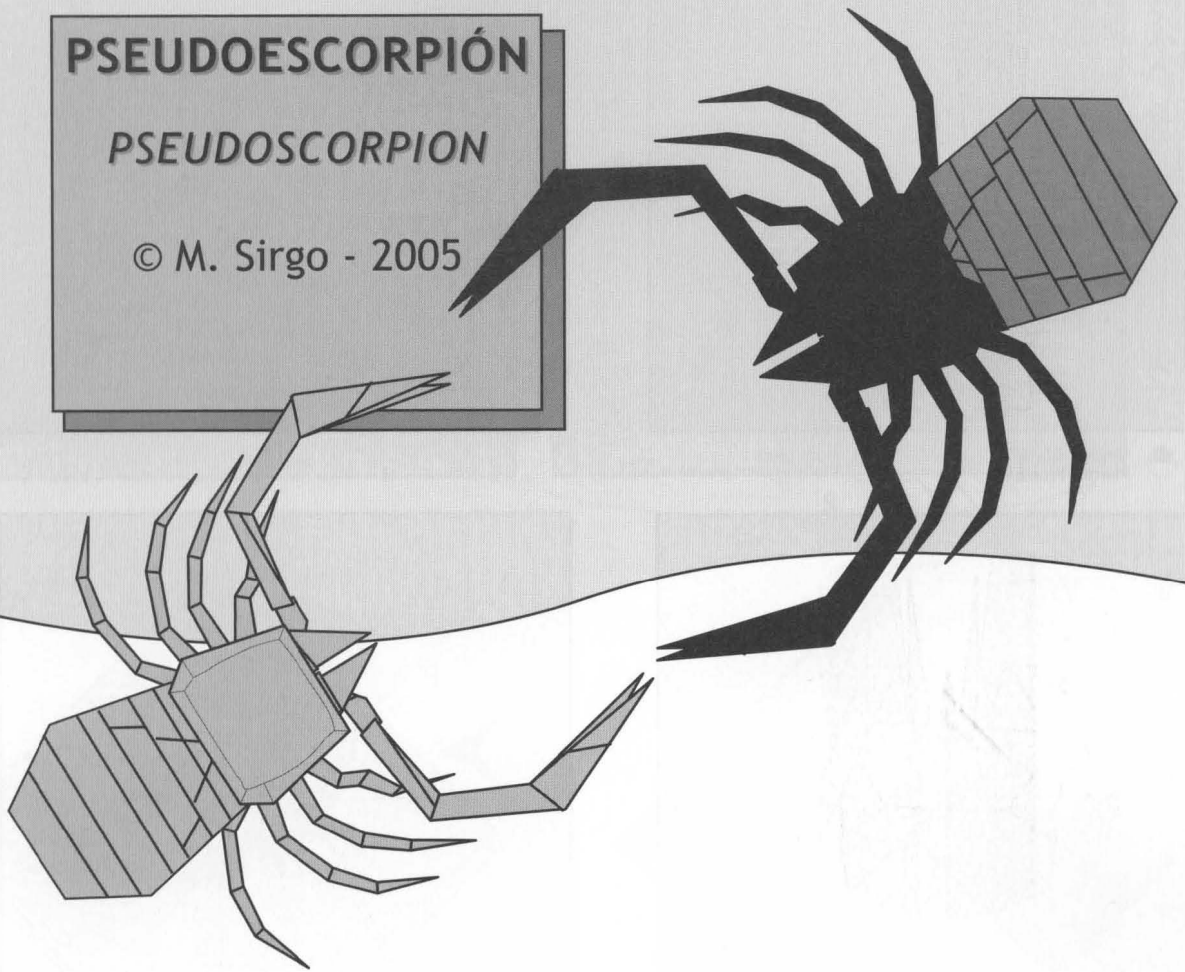

El papel debe ser marrón. Se recomienda papel fino, menor de 30 gramos, doble seda, o *sandwich* de 25x25 cm o mayor.

The paper should be brown. Fine paper is recommended, smaller than 30 grams, double silk, or *sandwich* of 25x25 cm or bigger.

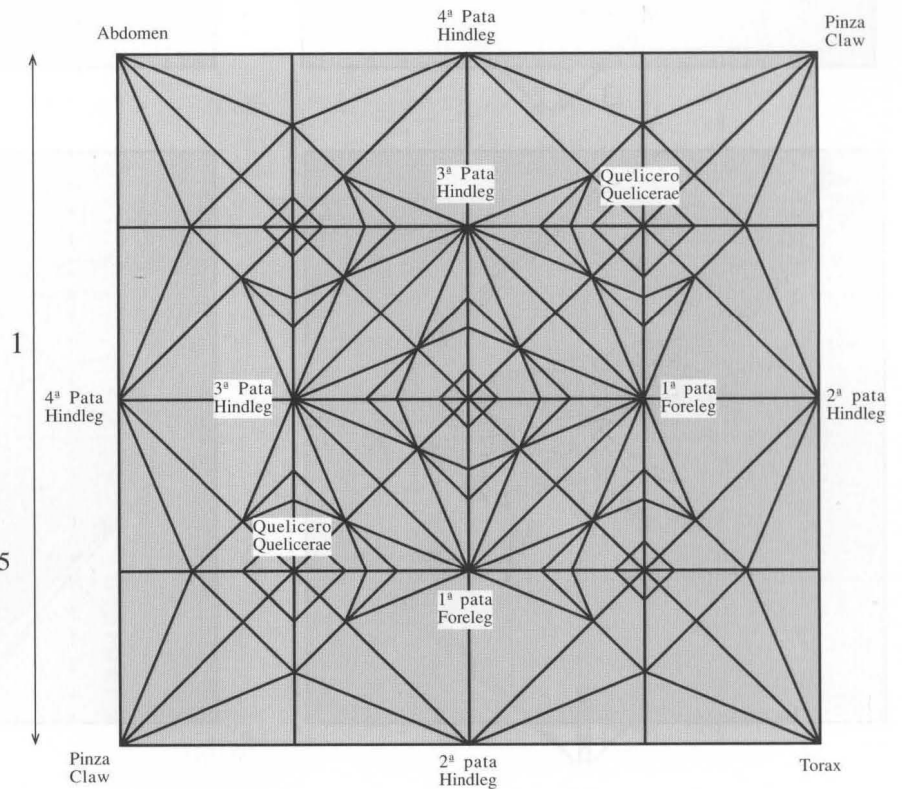
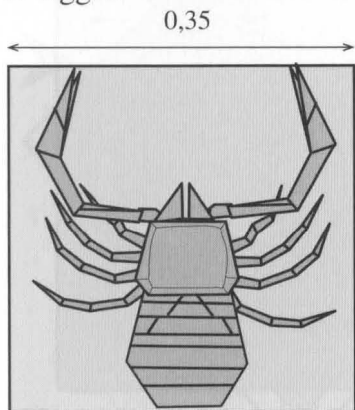

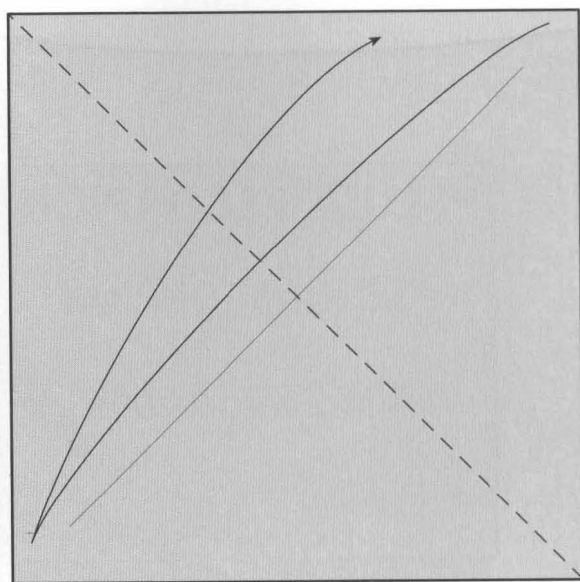
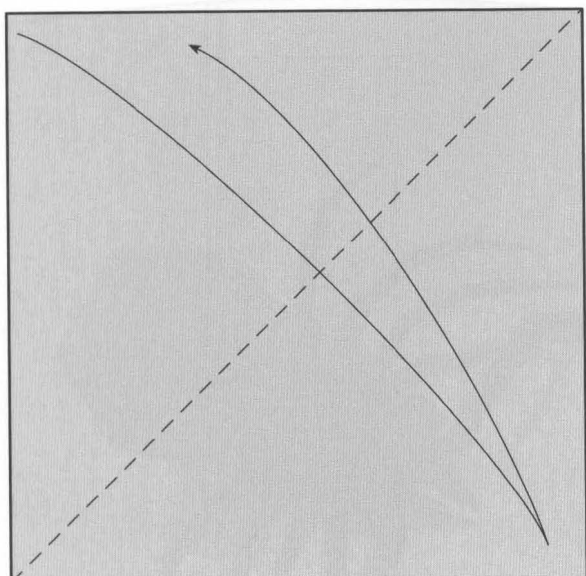

1 ● Negro, black
Marrón, brown

● Verde, green
Cualquier color, any colour

2

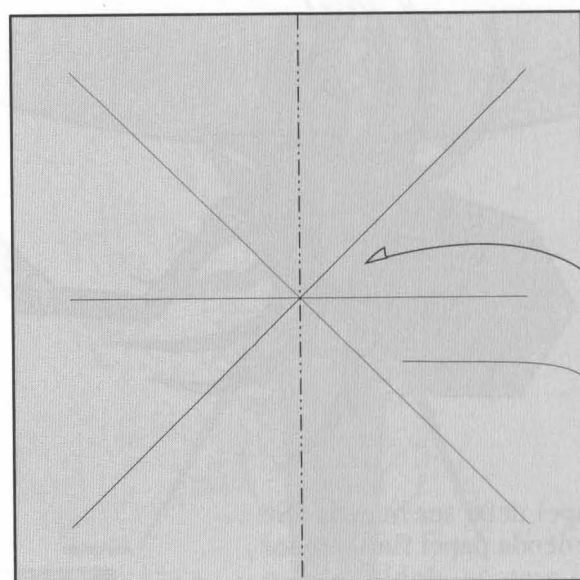
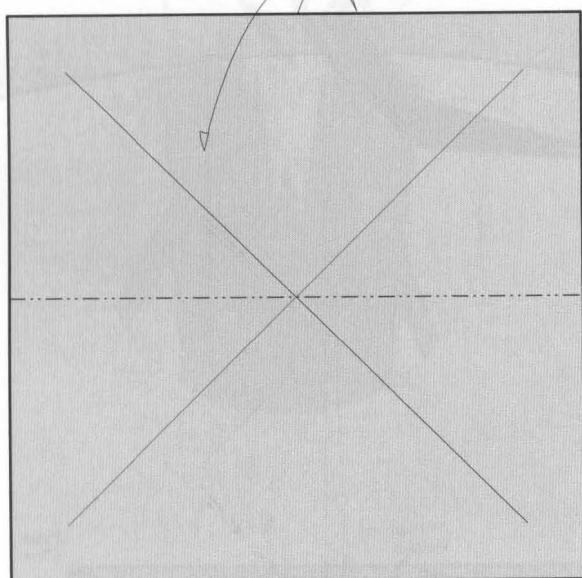

3

4

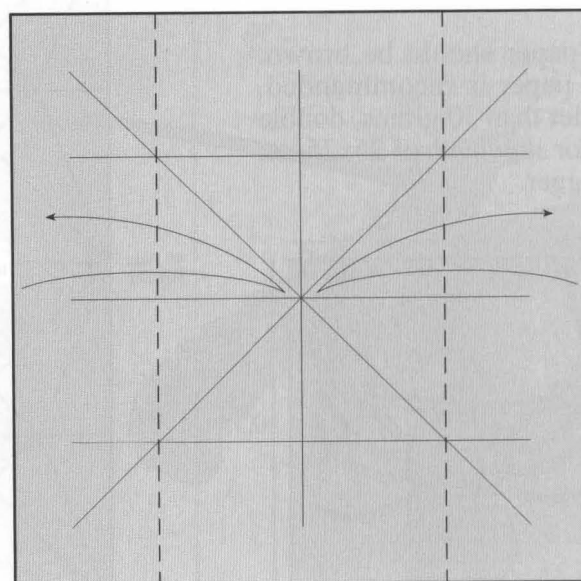
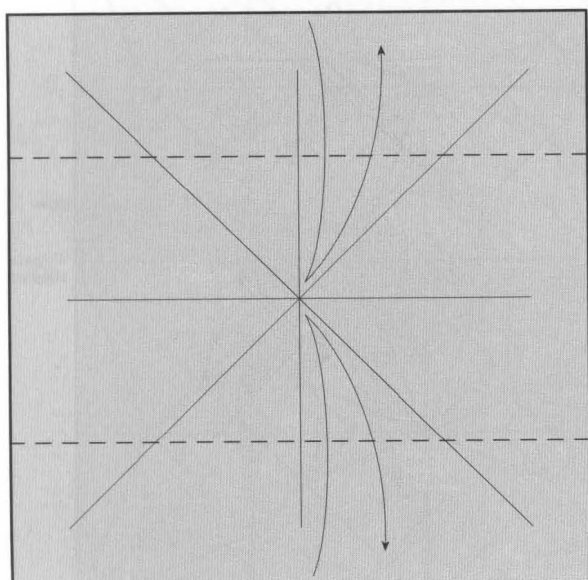

5

6

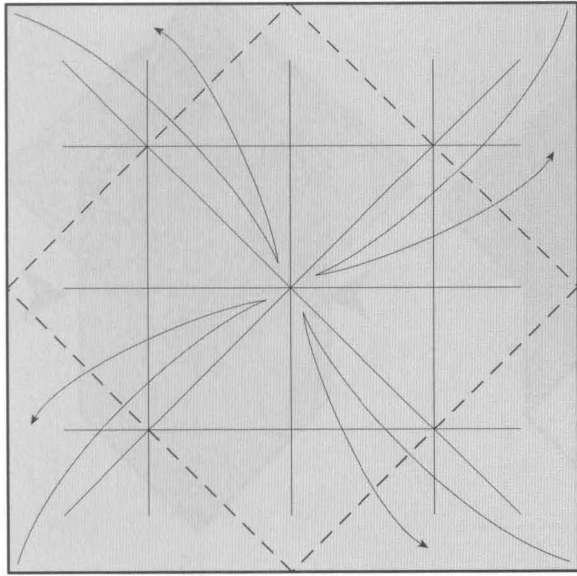

7

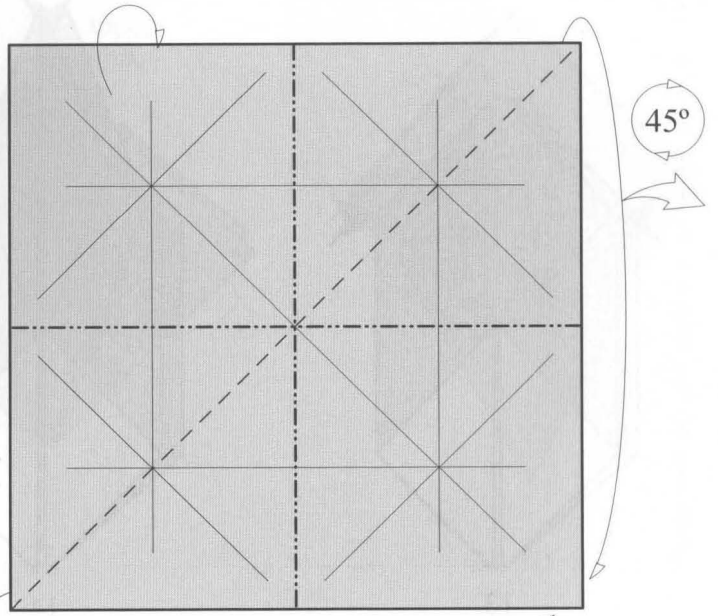

8

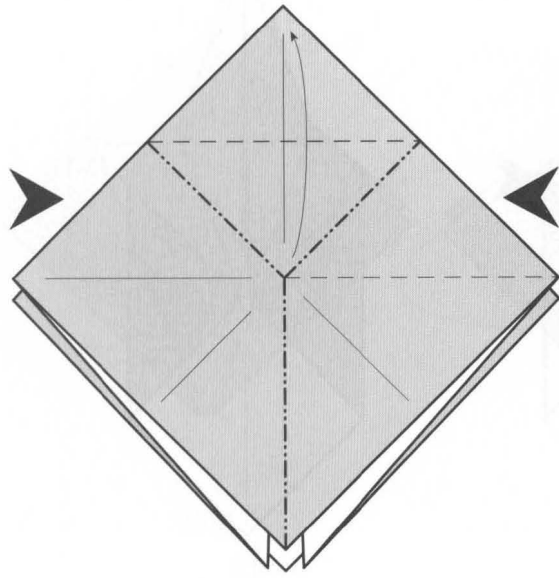

9

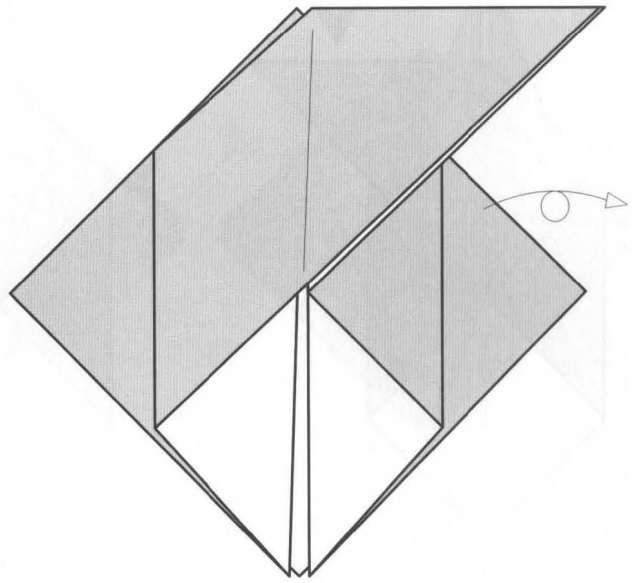

10

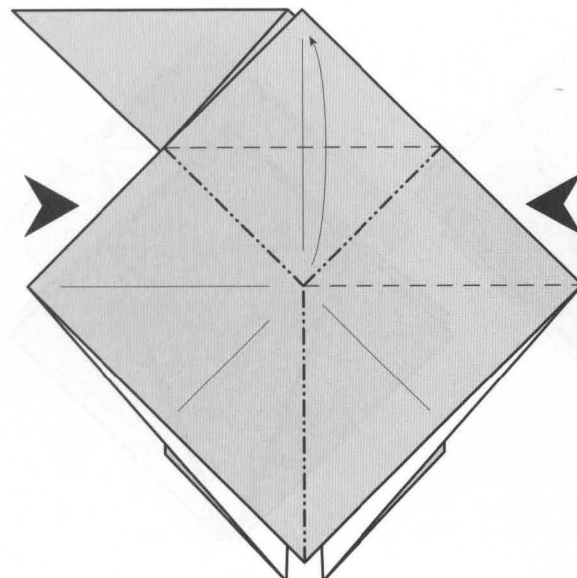

11

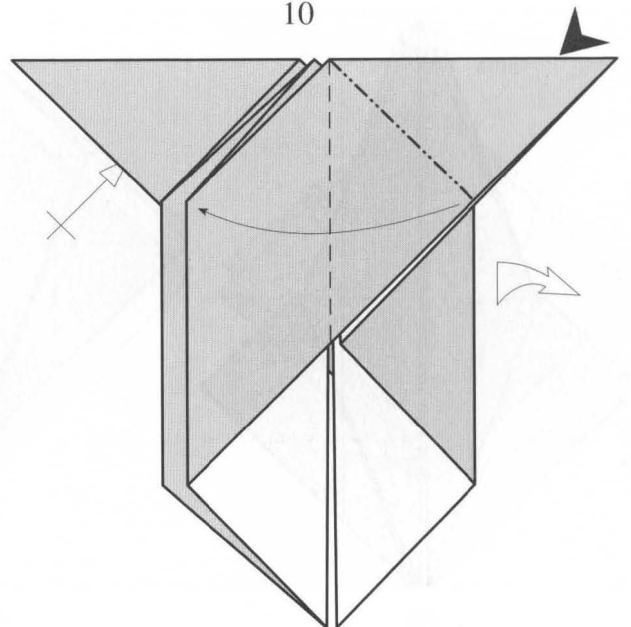

12

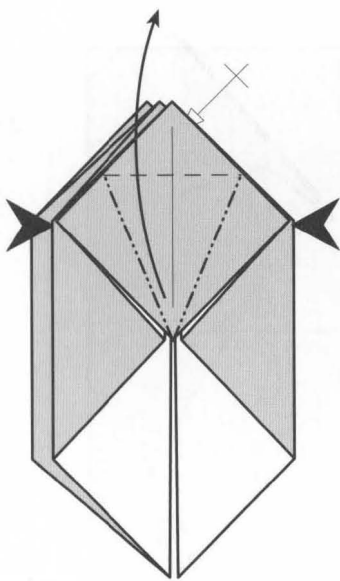

13

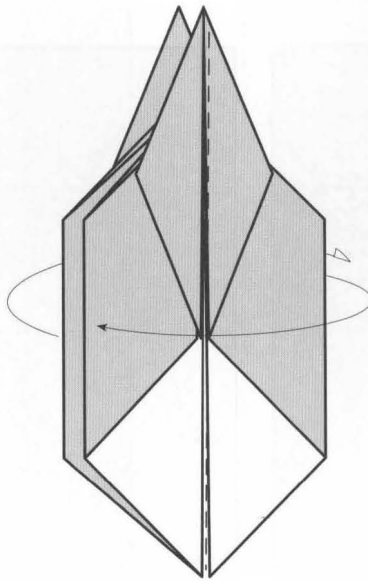

14

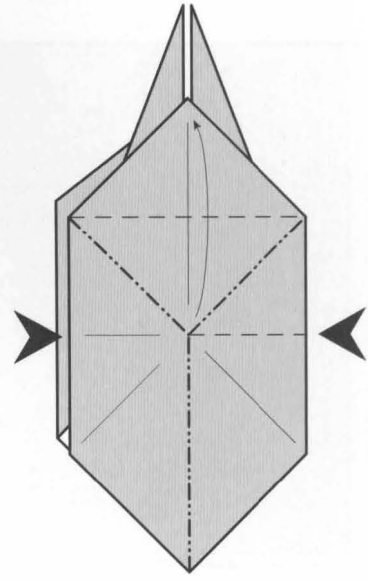

15

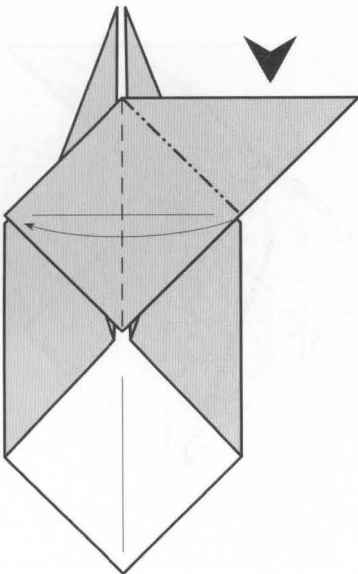

16

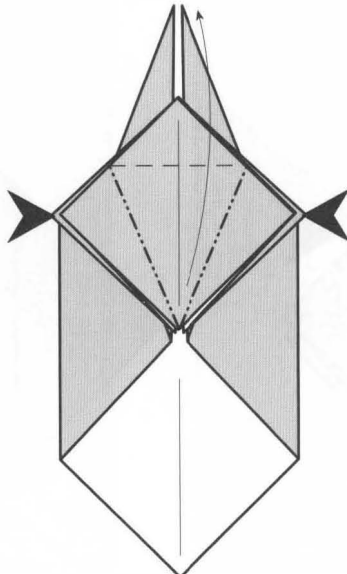

17

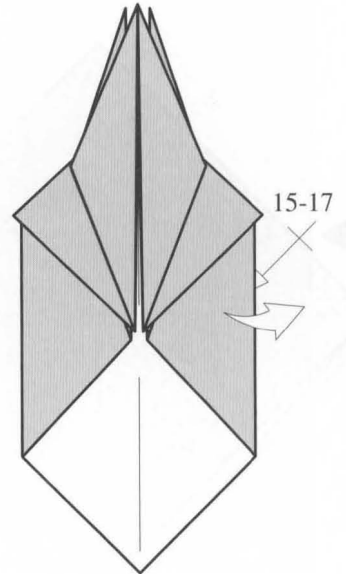

18

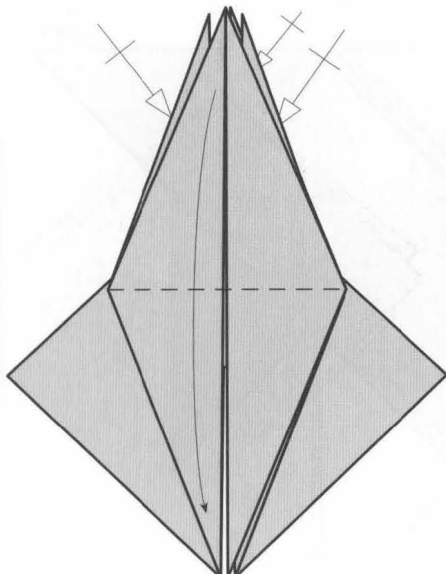

19

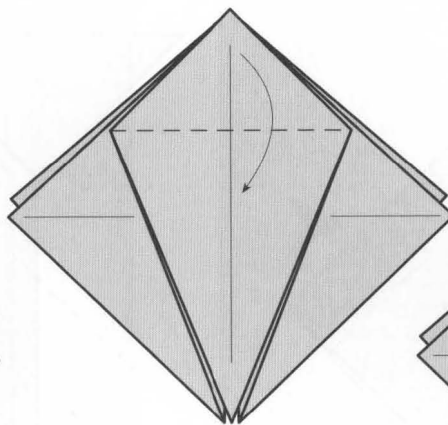

20

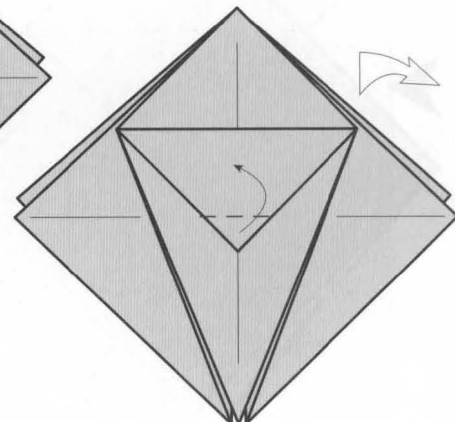

21

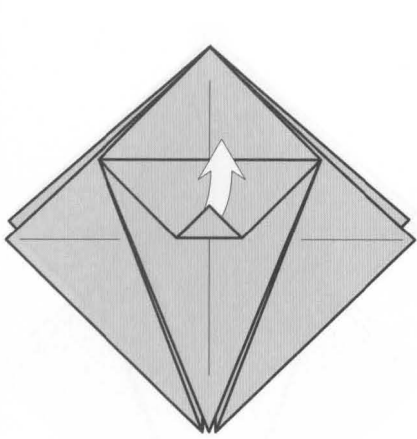

22

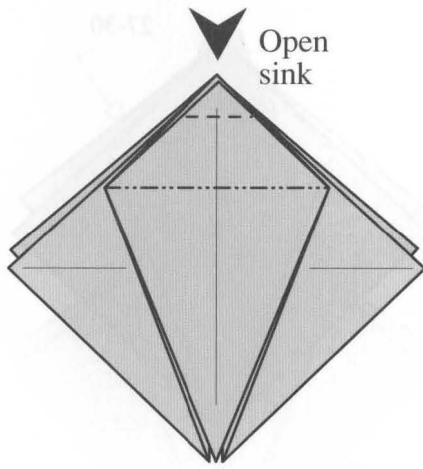

23

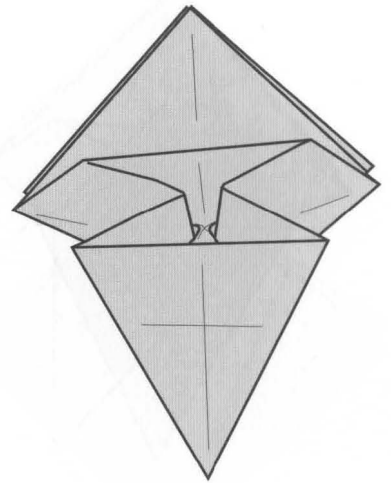

24-3D

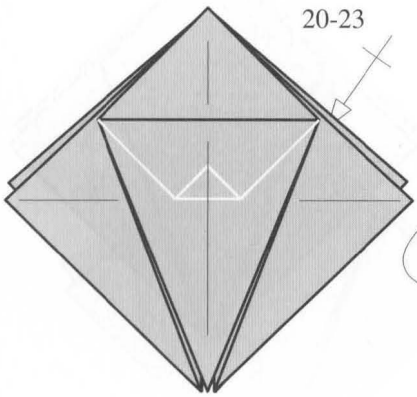

25 R-X

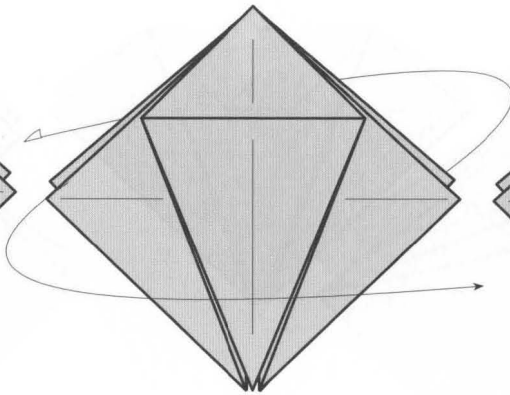

26

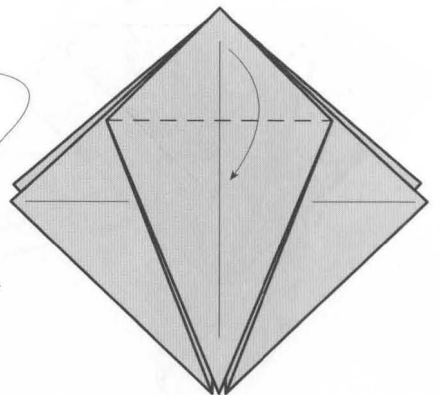

27

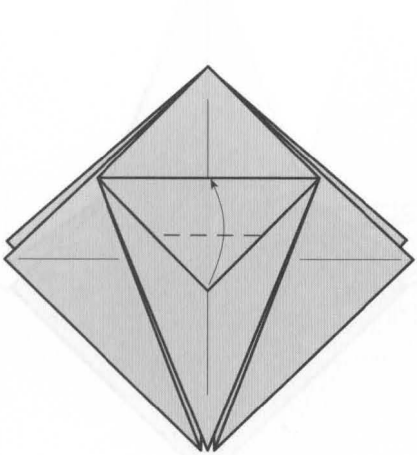

28

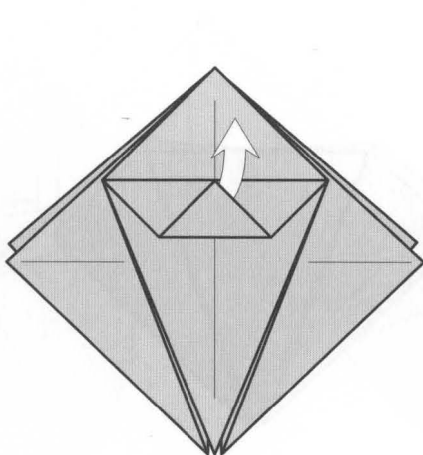

29

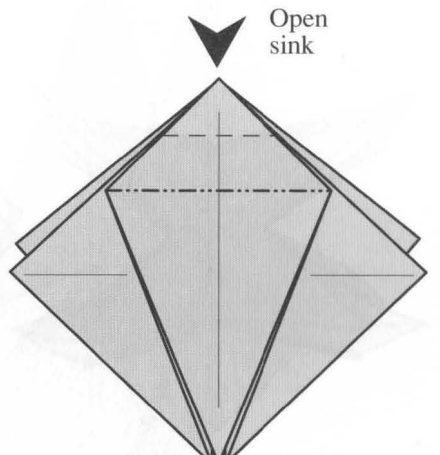

30

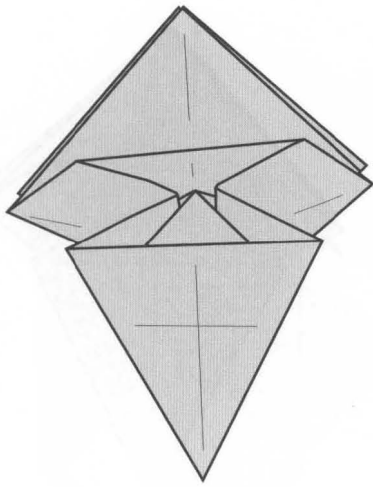

31-3D

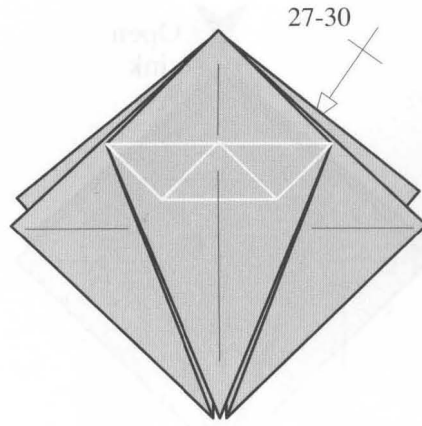

32 R-X

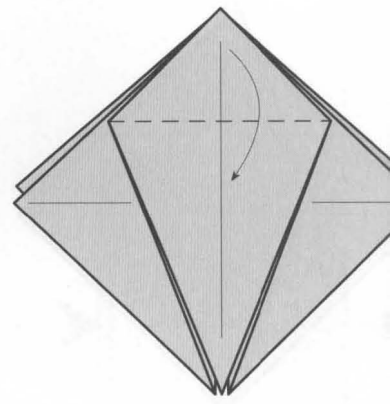

33

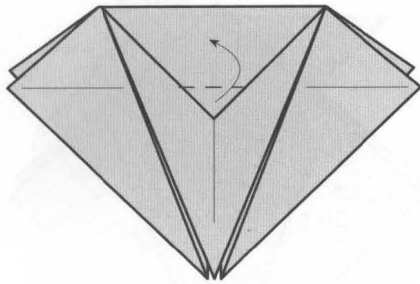

34

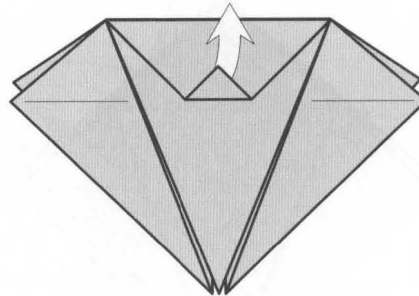

35

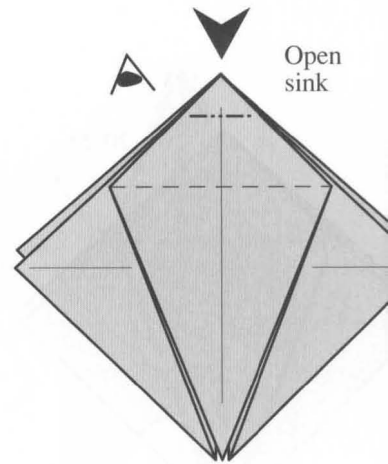

36

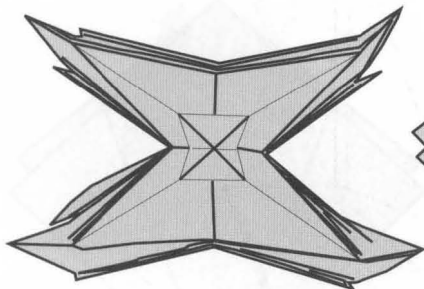

37-3D

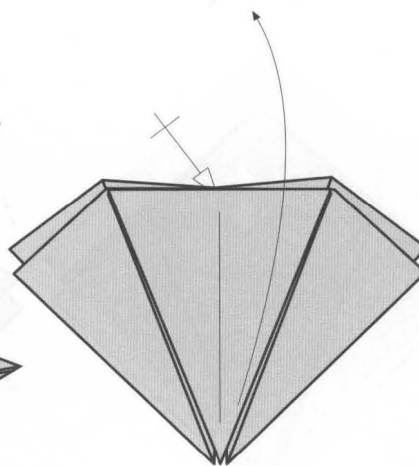

38

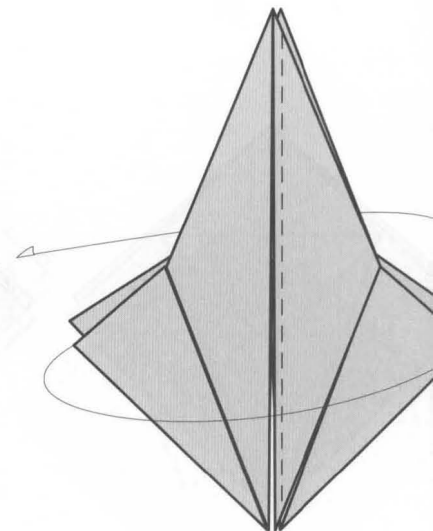

39

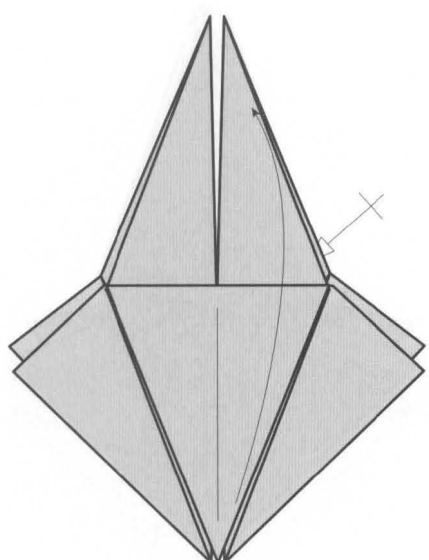

40

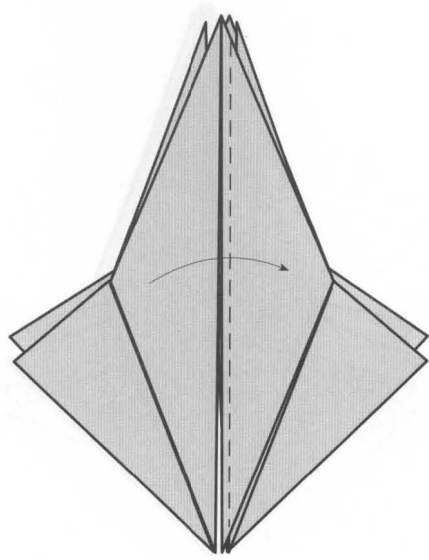

41

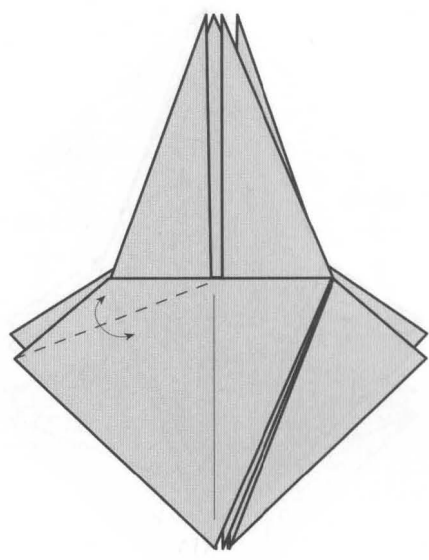

42

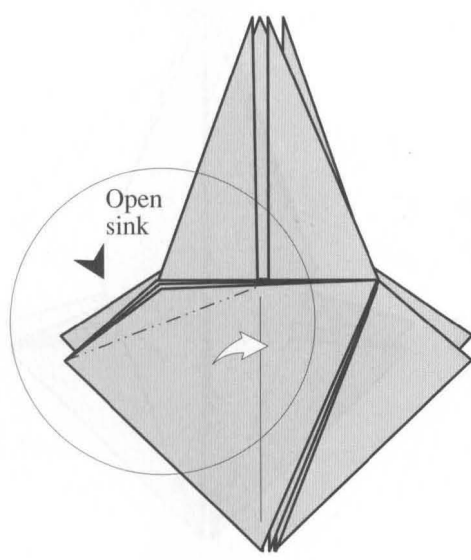

43

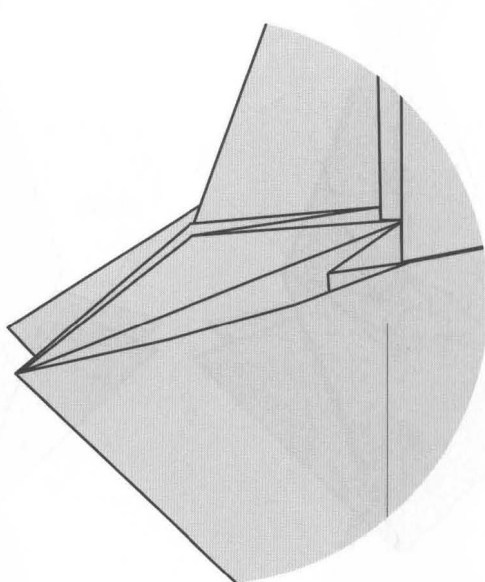

44

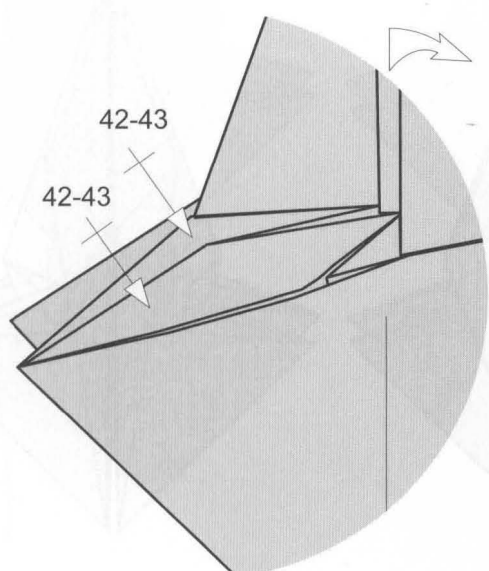

45

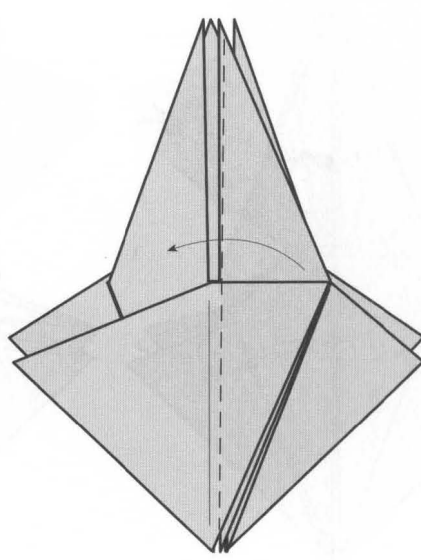

46

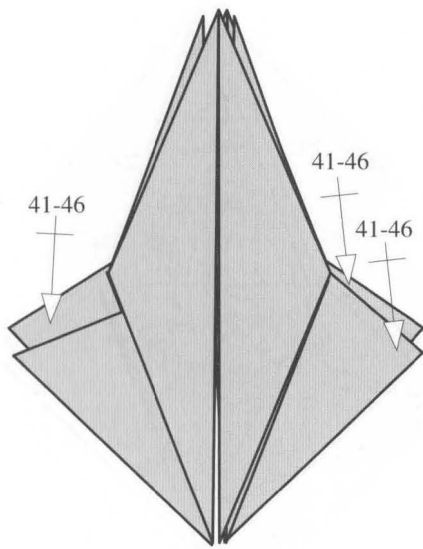

47

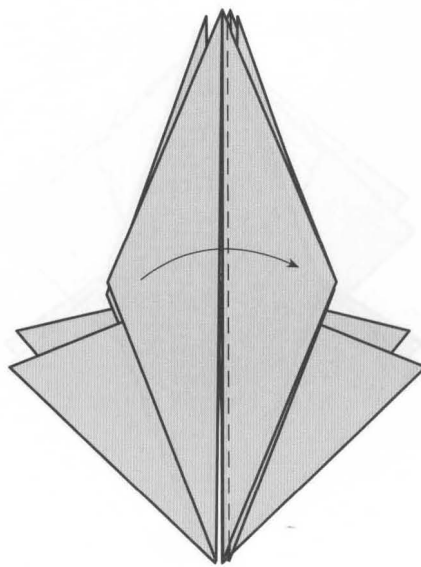

48

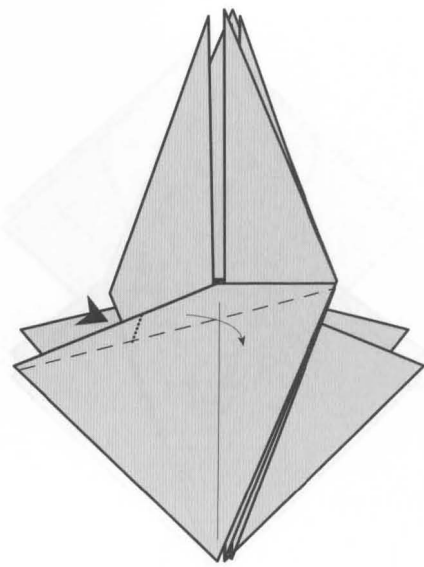

49

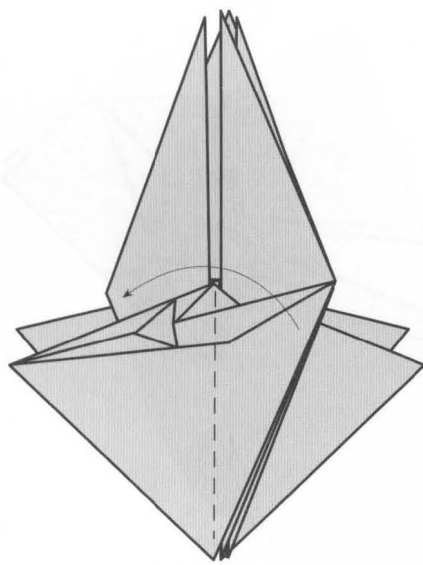

50

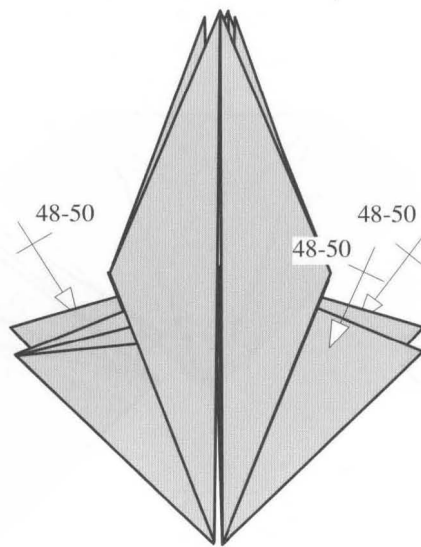

51

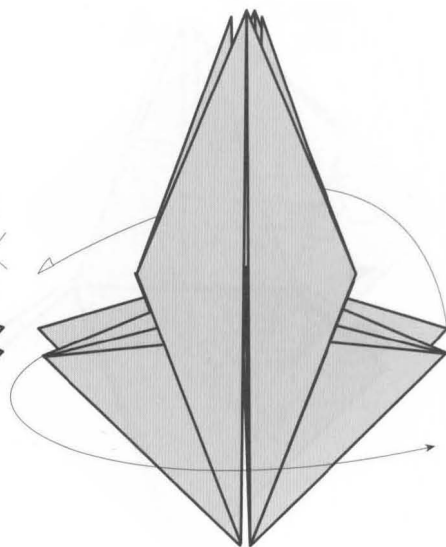

52

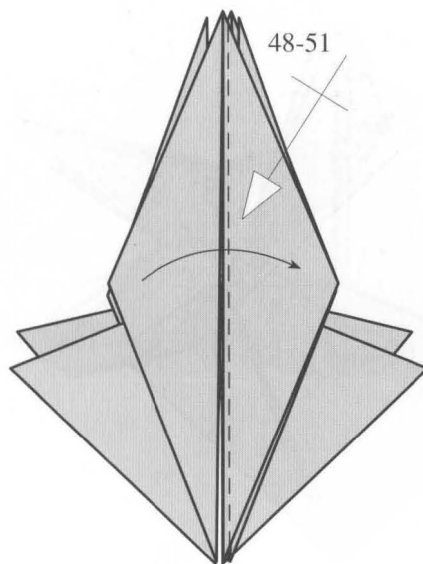

53

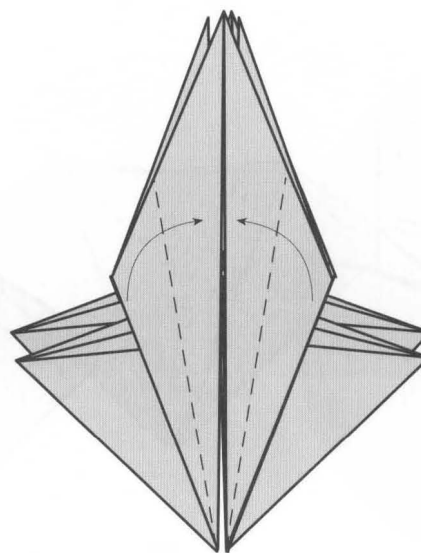

54

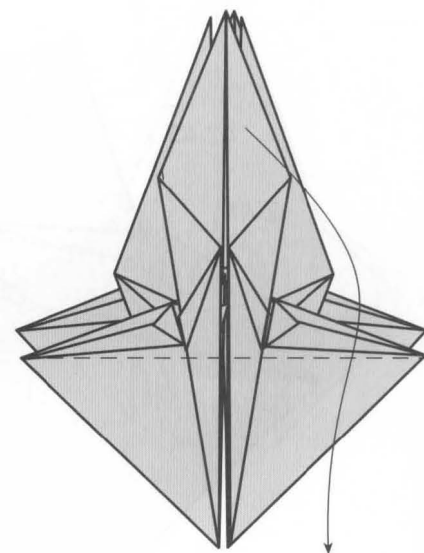

55

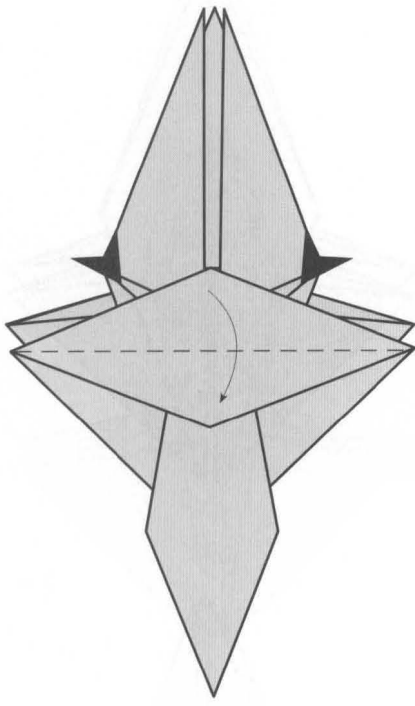

56

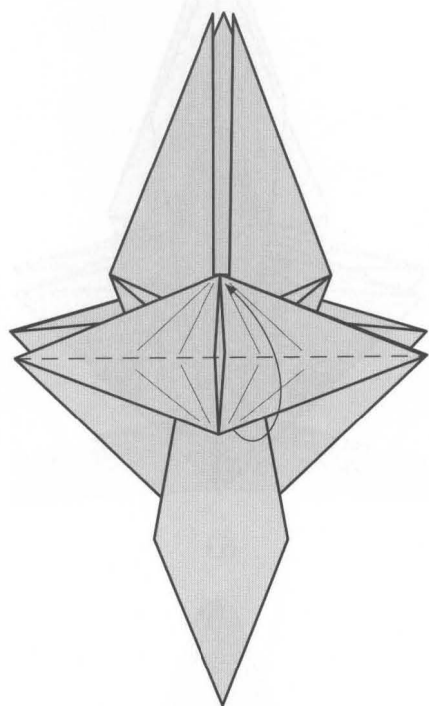

57

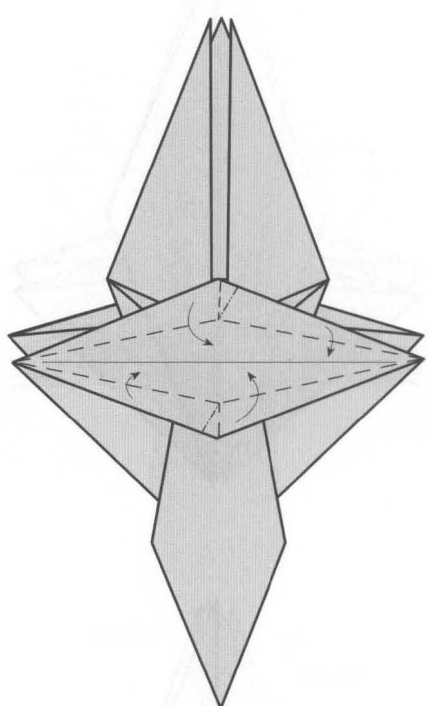

58

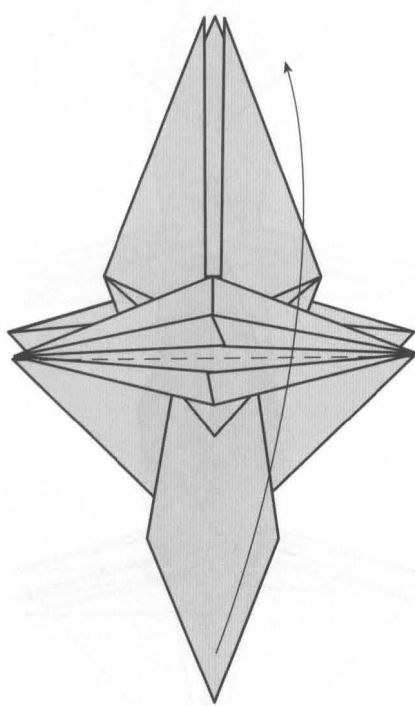

59

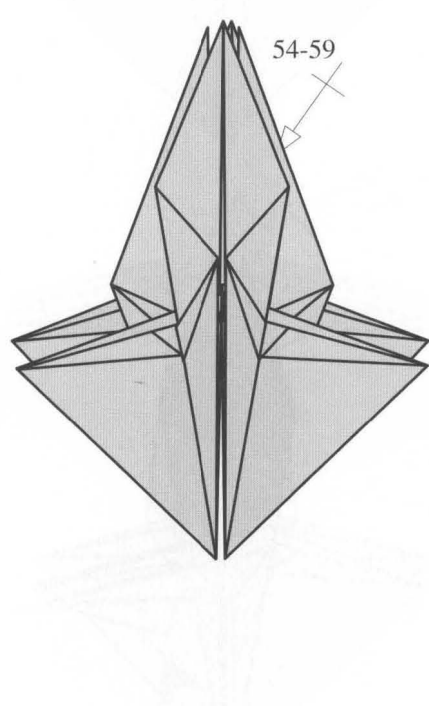

60

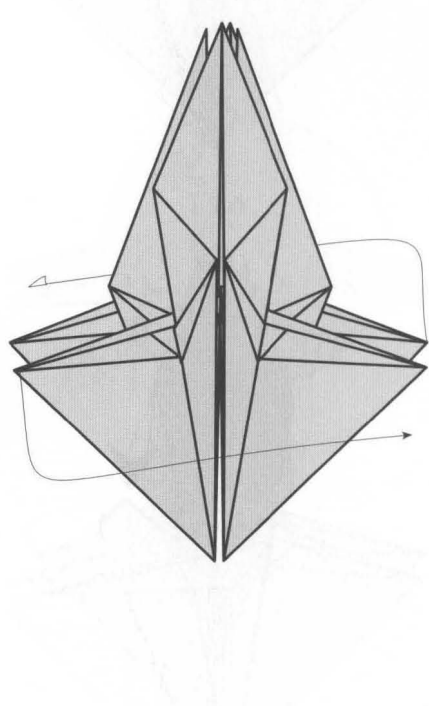

61

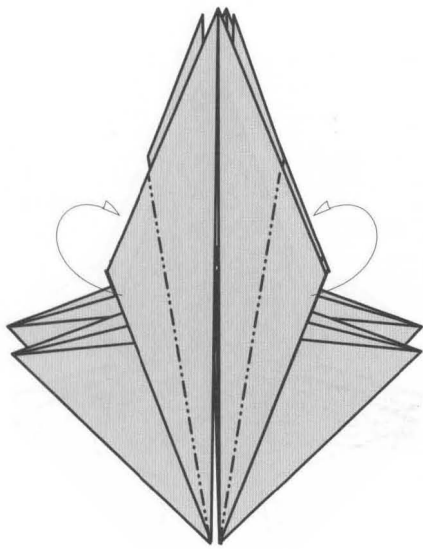

62

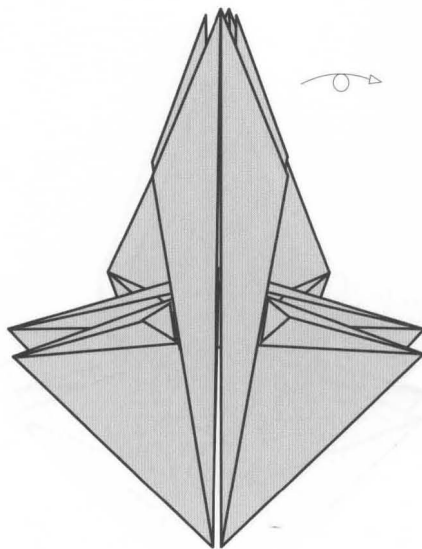

63

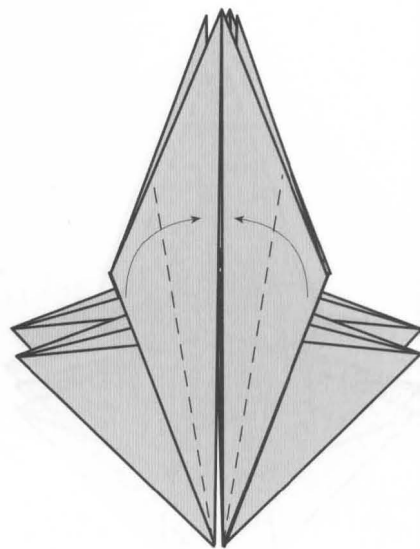

64

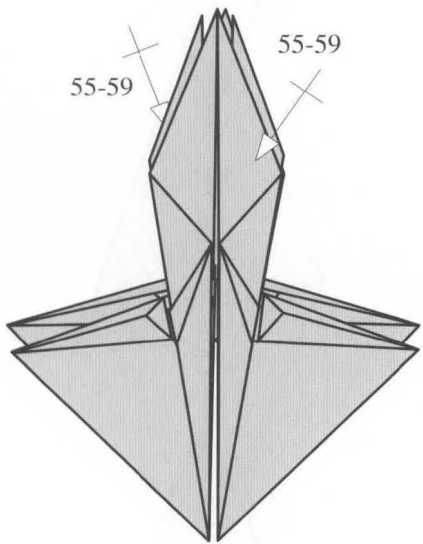

65

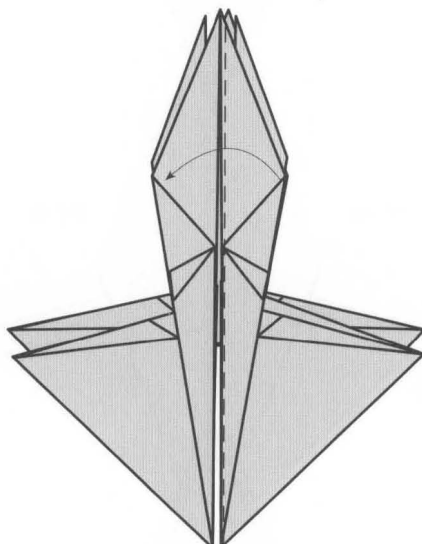

66

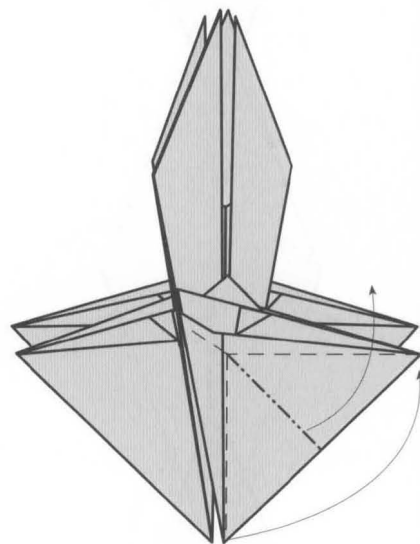

67

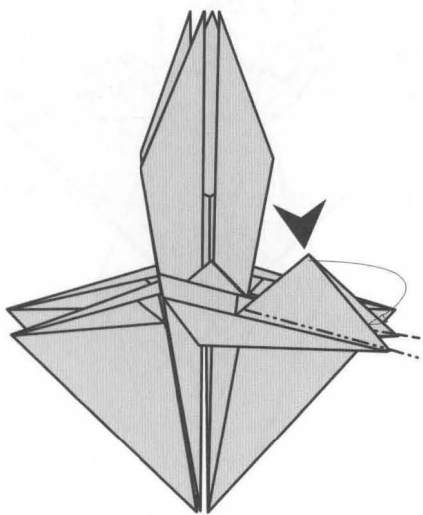

68

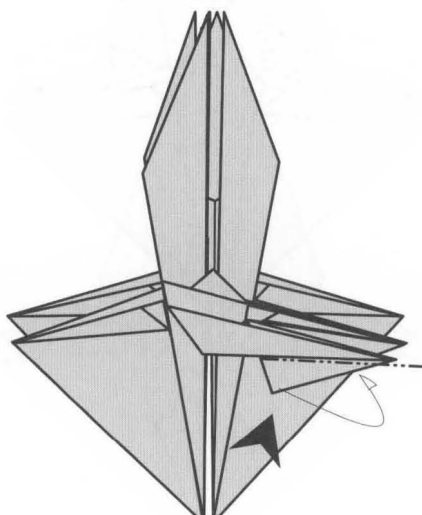

69

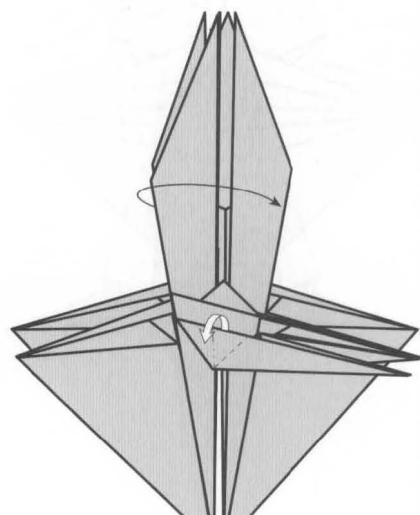

70

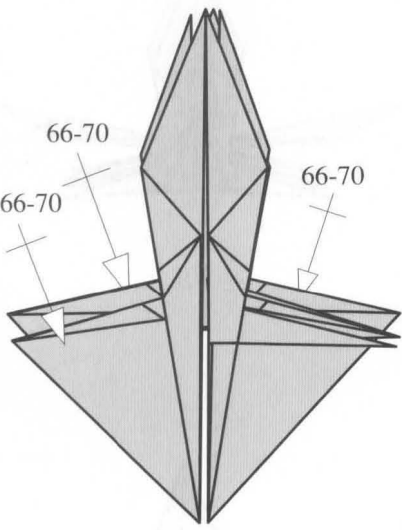

71

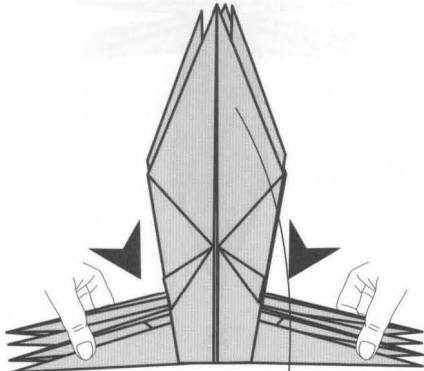

72

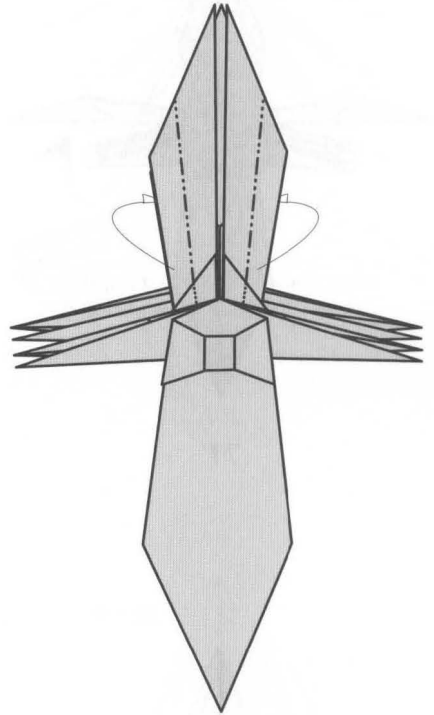

73

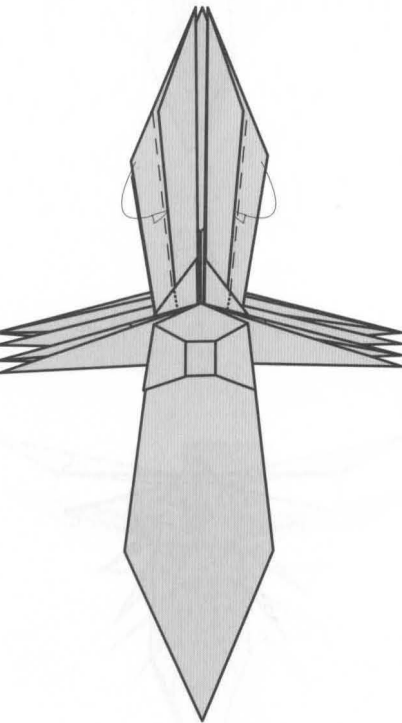

74

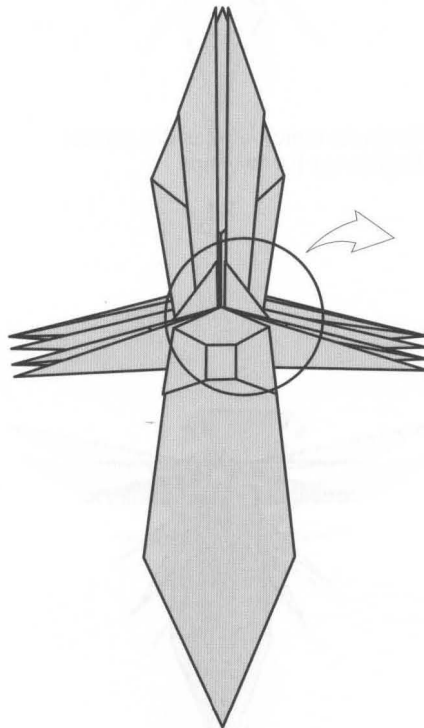

75

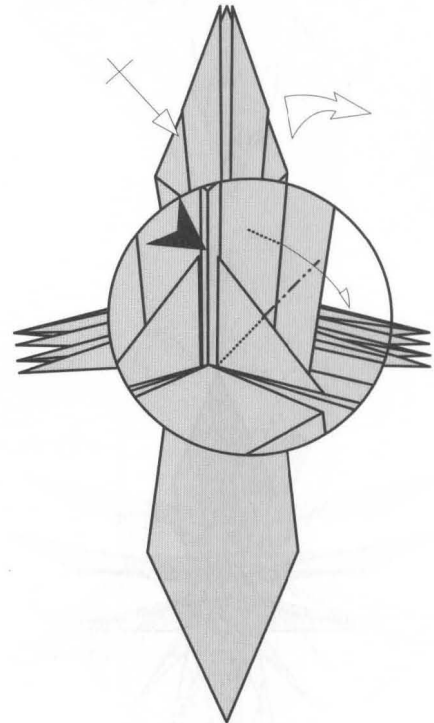

76

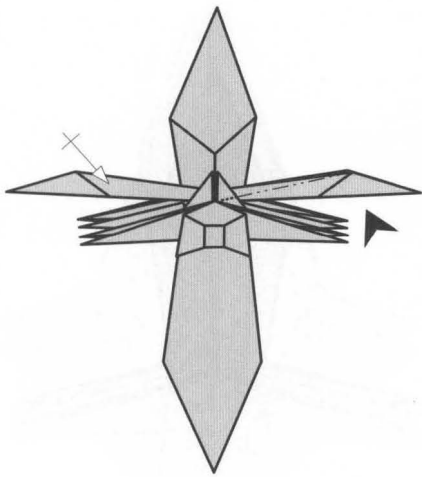

77

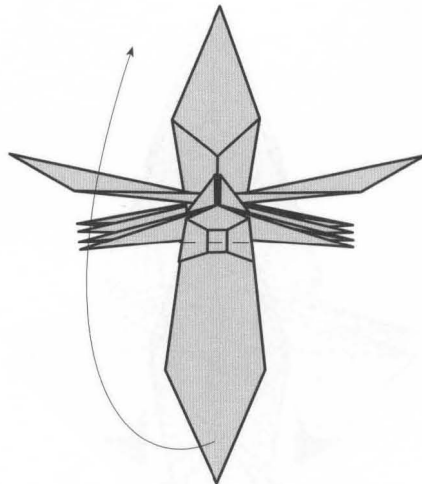

78

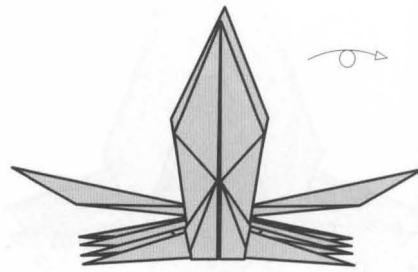

79

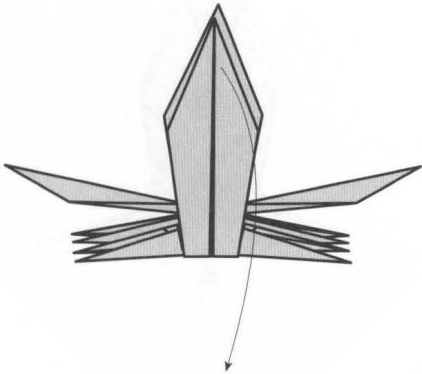

80

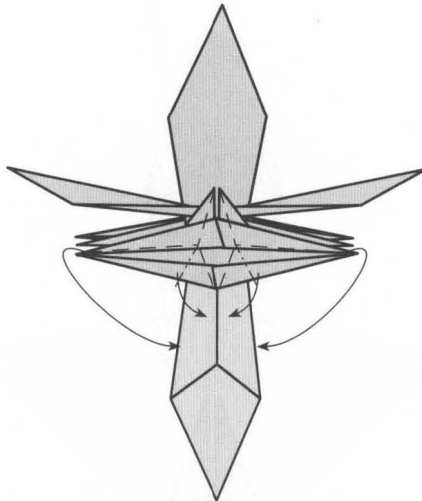

Oreja de conejo en las dos puntas
Rabbit ear for two tips

81

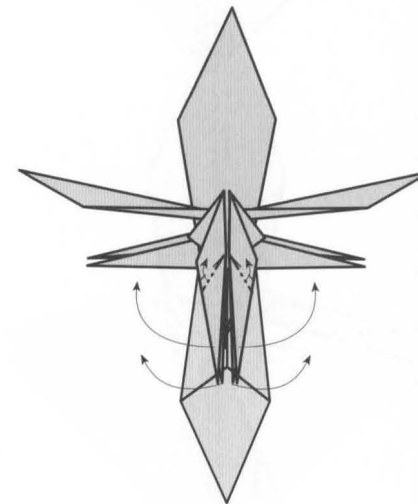

82

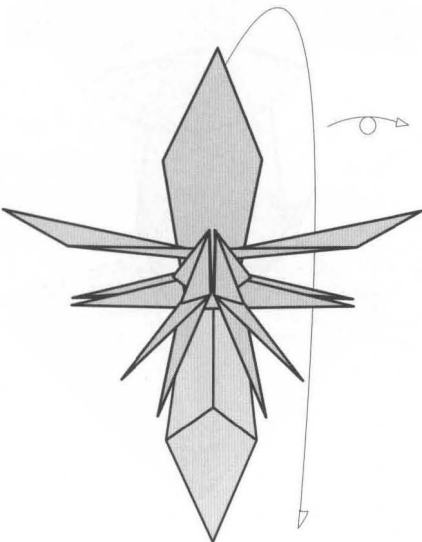

83

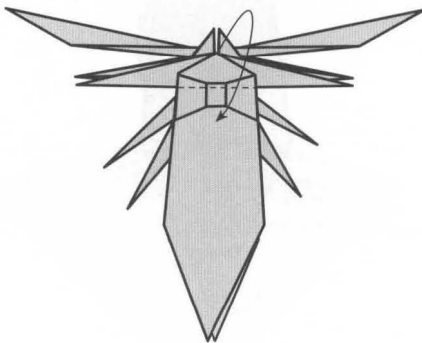

Dos capas
Two Layers

84

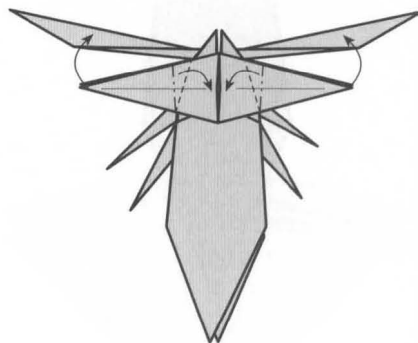

85

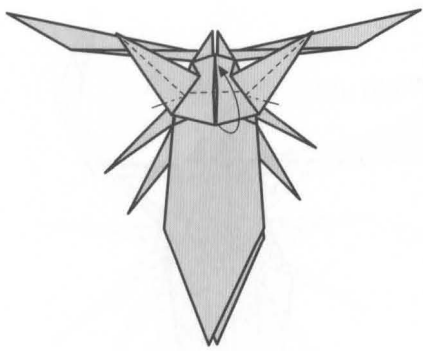

86

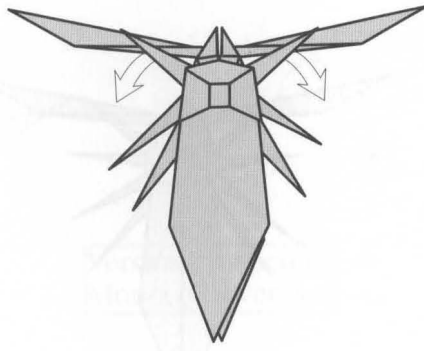

87

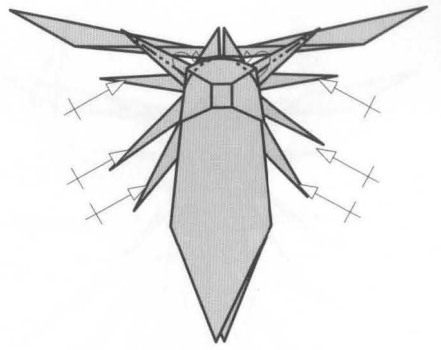

Oreja de conejo en cada pata
Rabbit ear in each leg

88

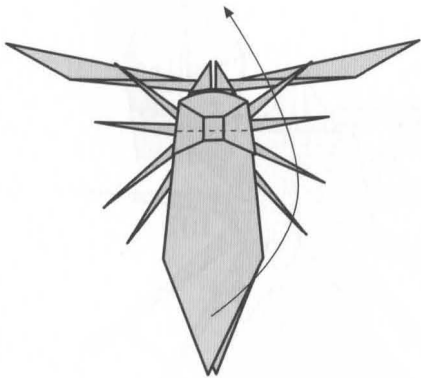

89

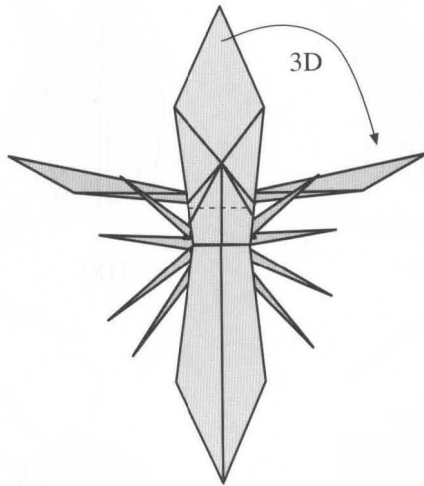

90

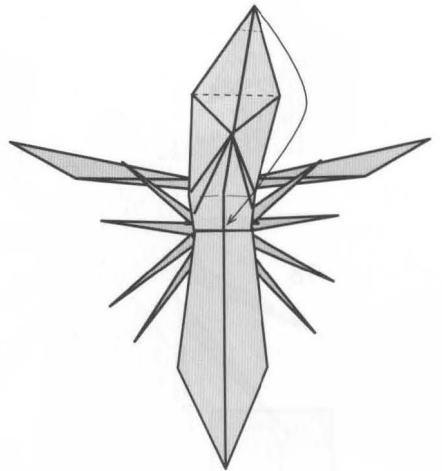

91

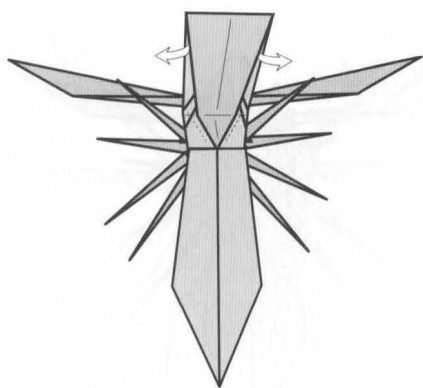

92

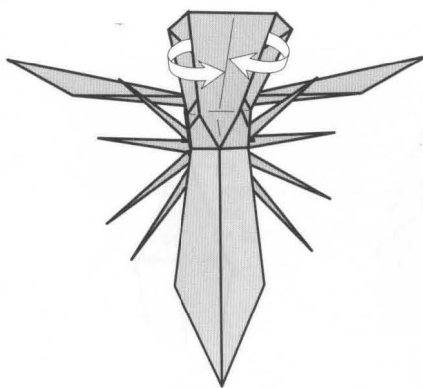

93

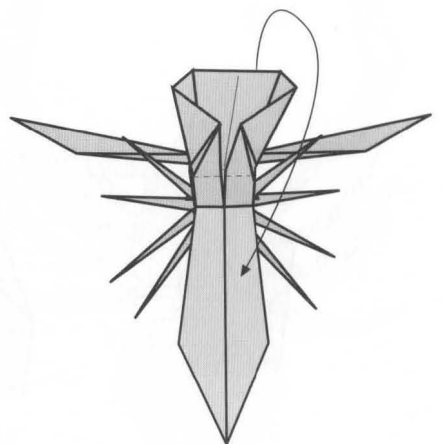

94

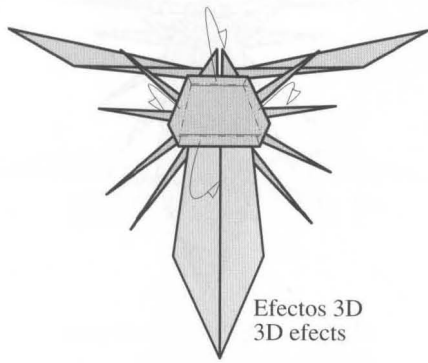

95

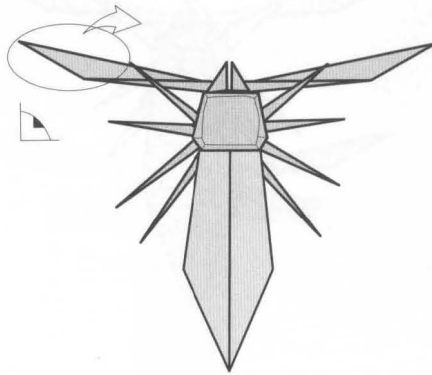

96

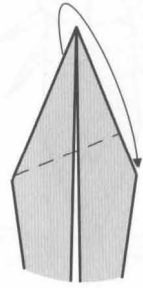

97

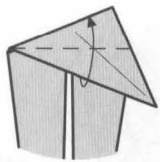

98

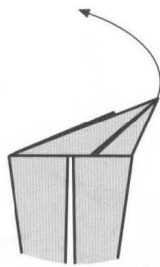

99

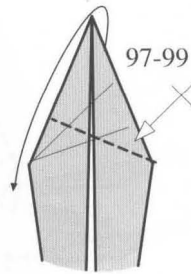

100

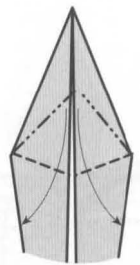

101

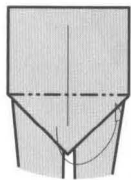

102

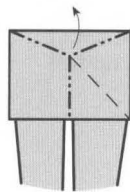

103

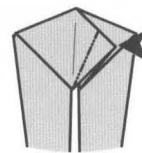

104

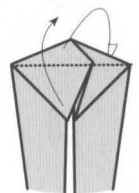

105

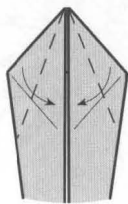

106

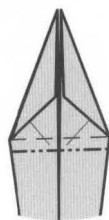

107

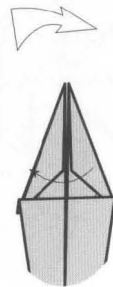

108

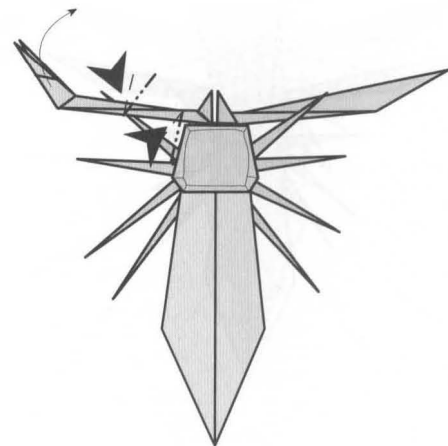

109

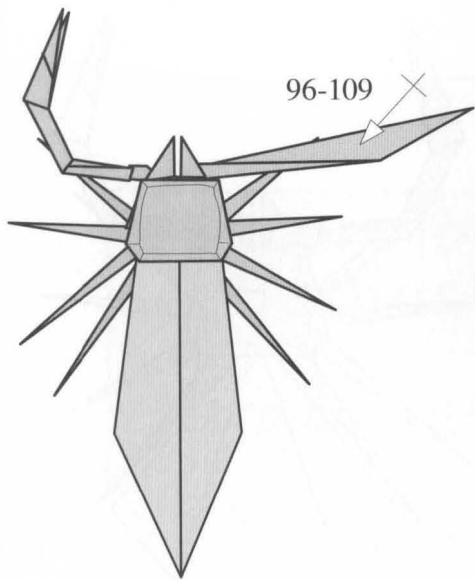

110

Versión monocolor
Monocolor version

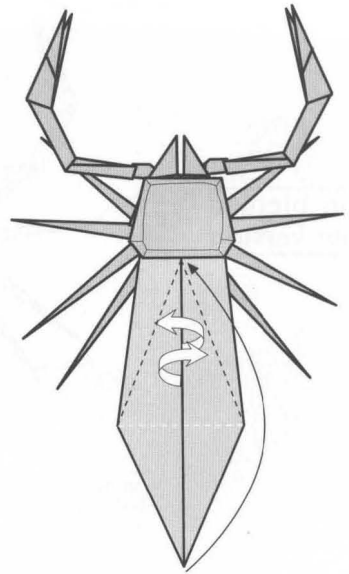

111

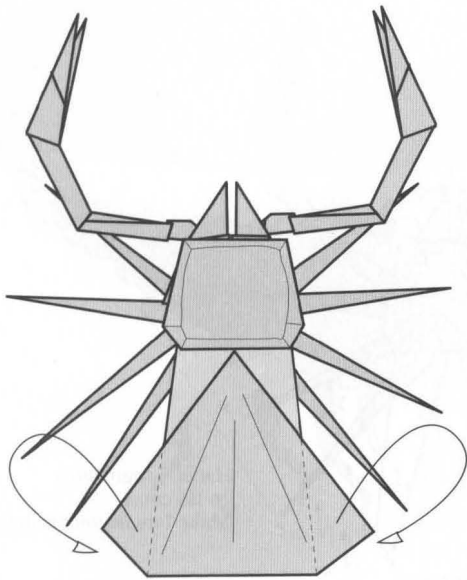

112

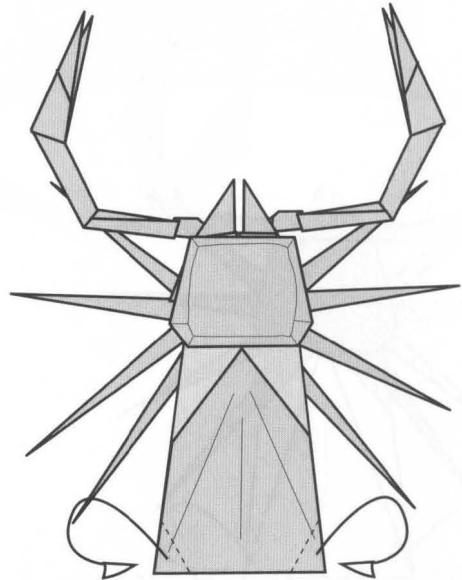

113

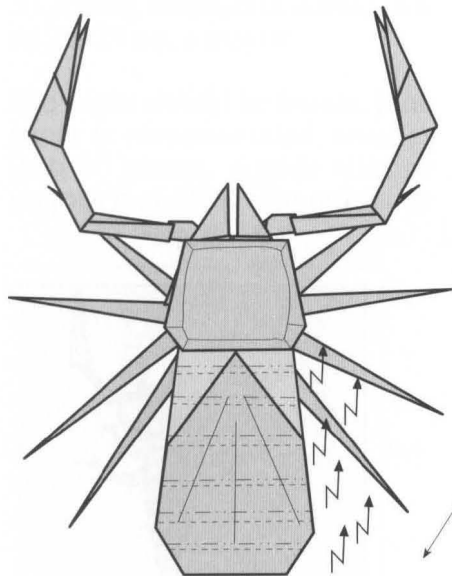

114

Hacer 4 segmentos
en las patas
Make four segments in the legs

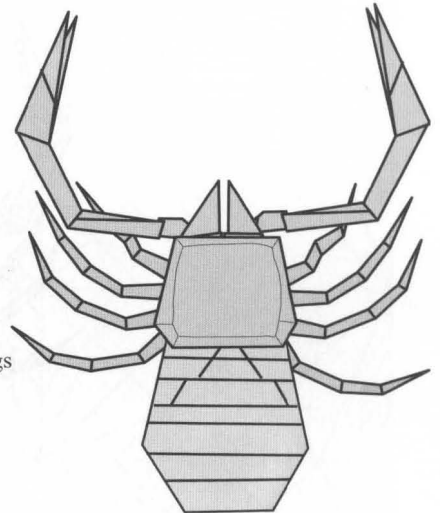

115

Versión bicolor
Bicolour version

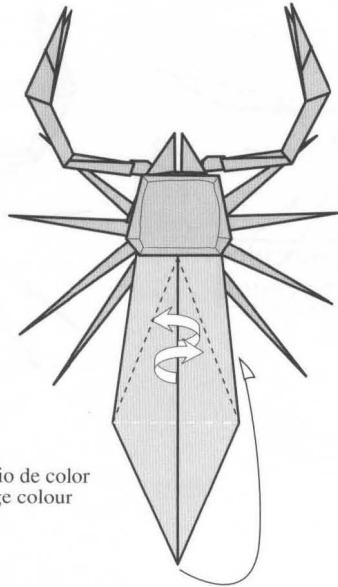

Cambio de color
Change colour

111

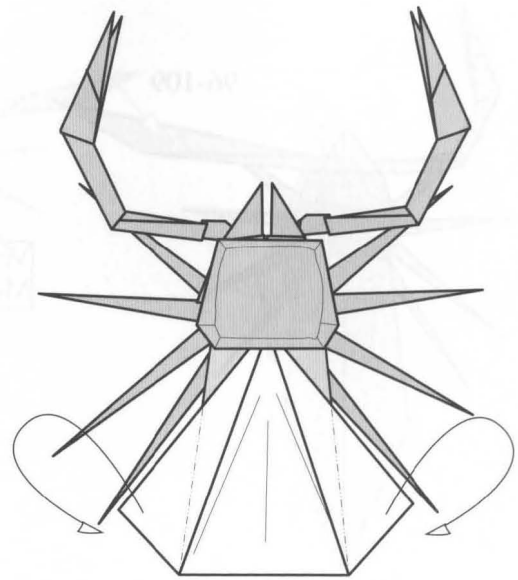

112

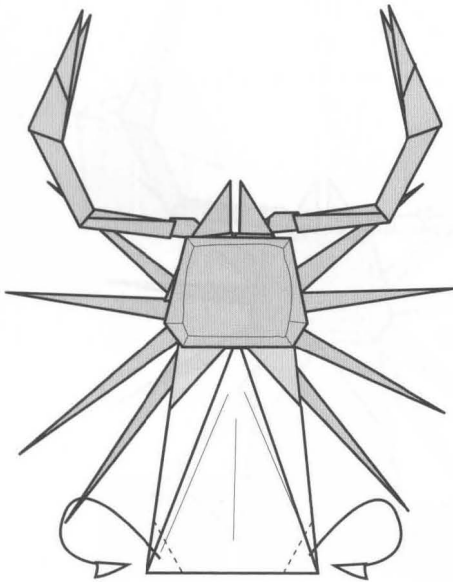

113

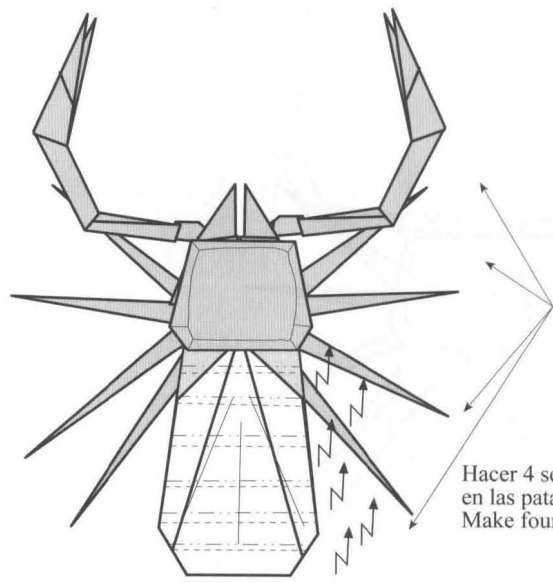

Hacer 4 segmentos
en las patas
Make four segments in the legs

114

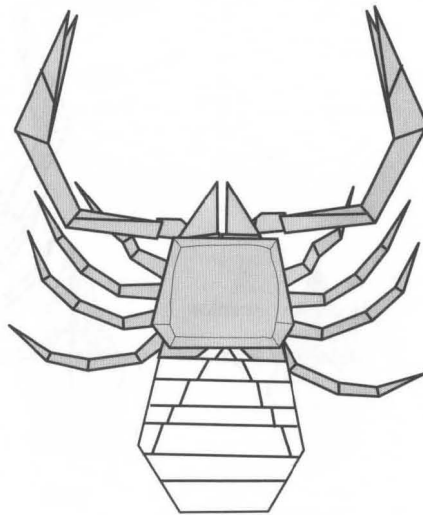

115

Escorpión Buthus

Scorpion Buthus

© M. Sirgo - 2002

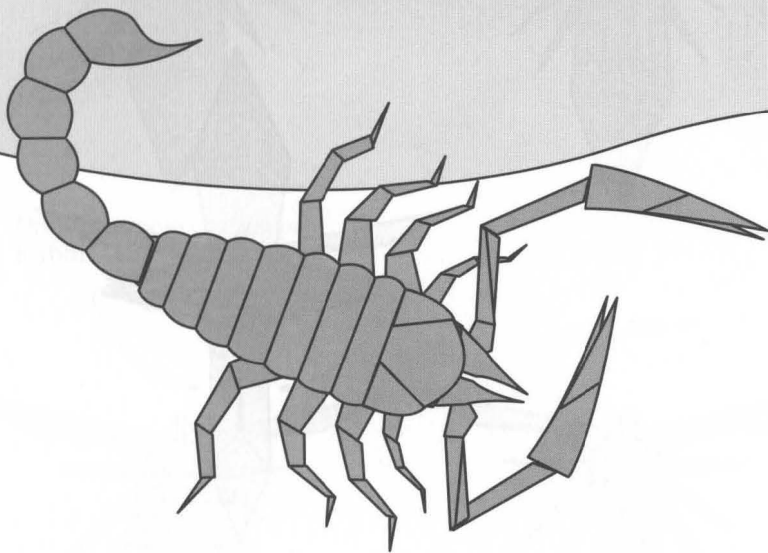
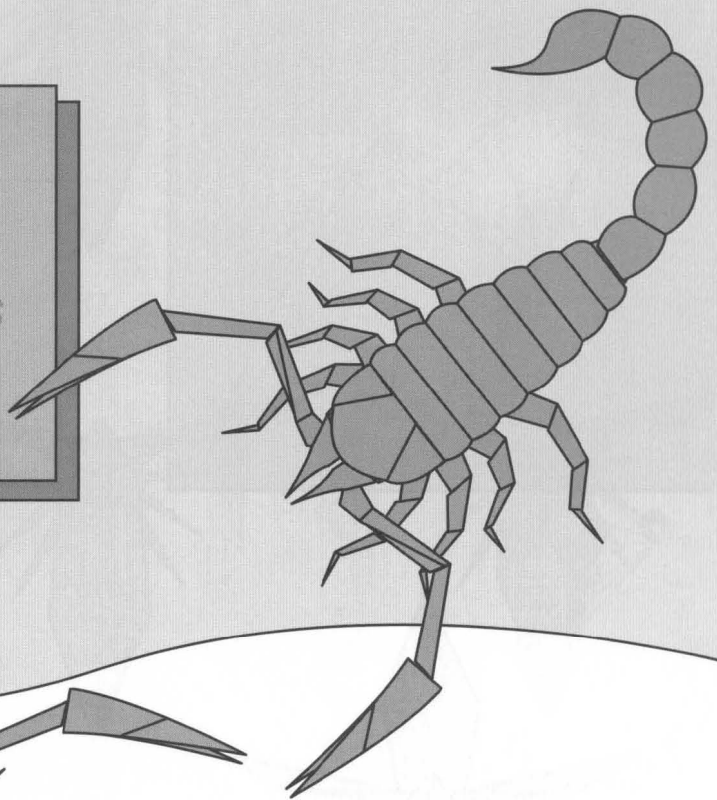

El papel debe ser marrón. Se recomienda papel fino, menor de 30 gramos, doble seda, o *sandwich* de 25x25 cm o mayor.

The paper should be brown. Fine paper is recommended, smaller than 30 grams, double silk, or *sandwich* of 25x25 cm or bigger.

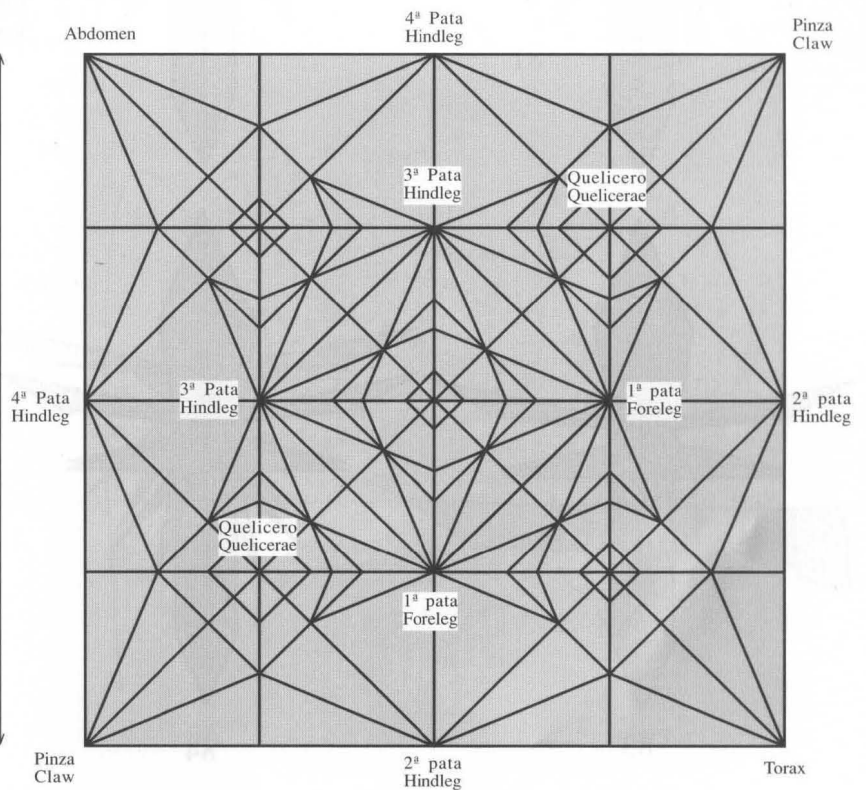
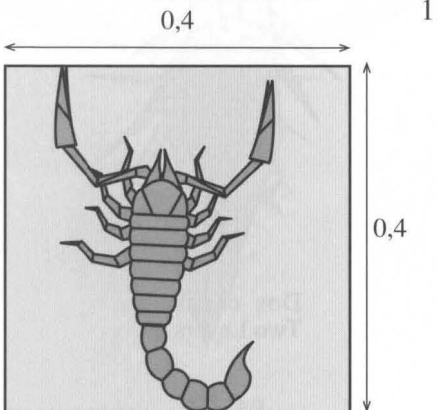

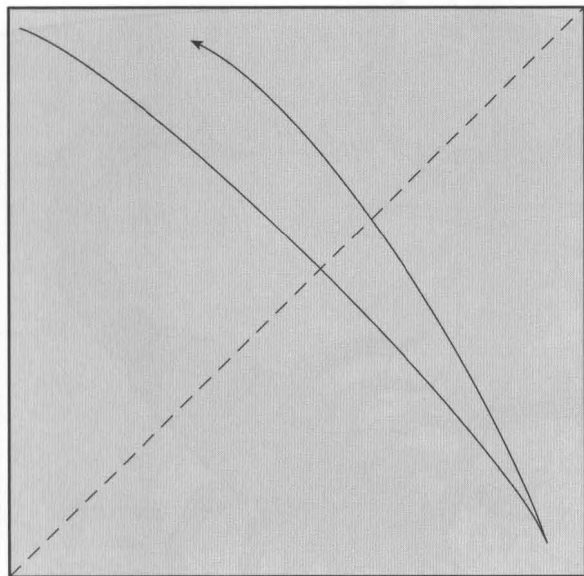

1

Pasos 2 al 80 del Pseudoescorpión
Steps 2 until 80 of Pseudoscorpion

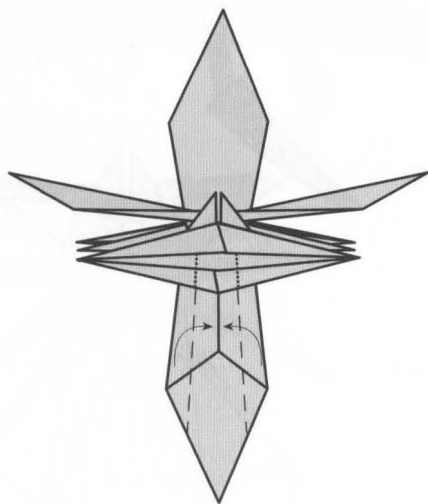

81

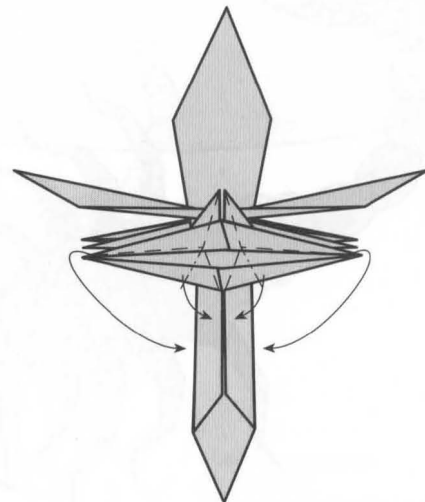

Oreja de conejo en las dos puntas
Rabbit ear for two tips

82

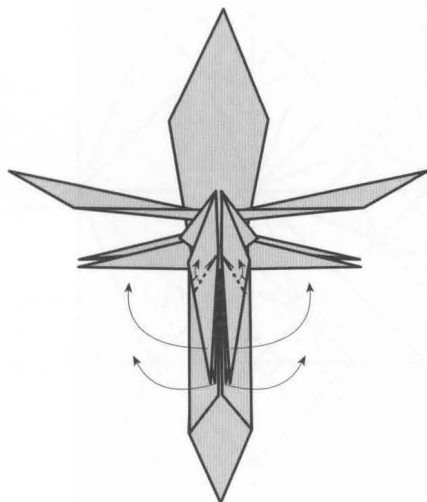

83

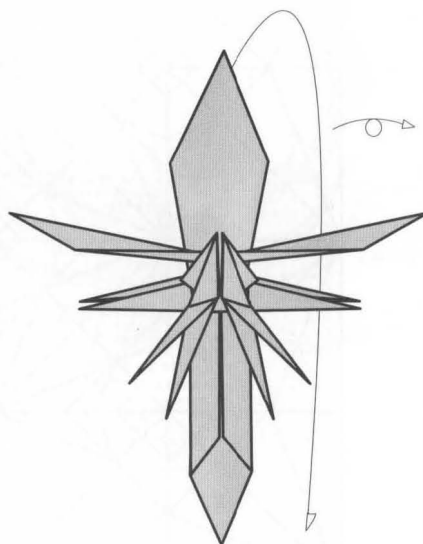

84

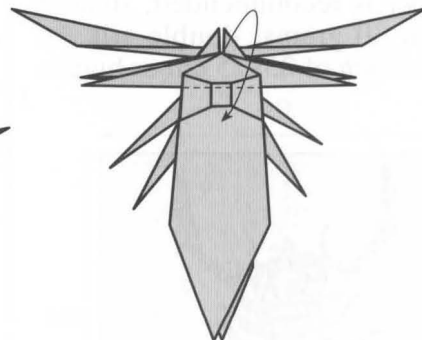

Dos capas
Two Layers

85

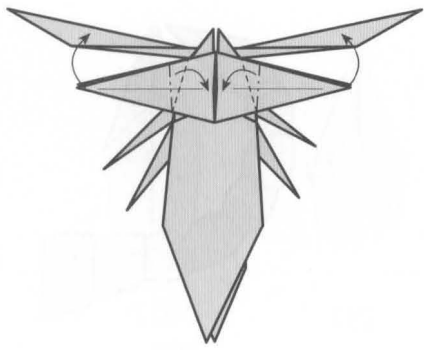

86

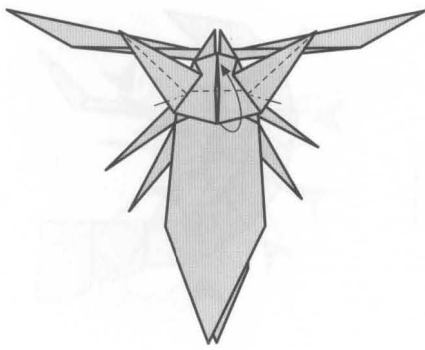

87

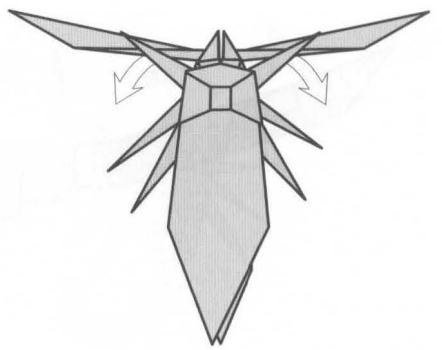

88

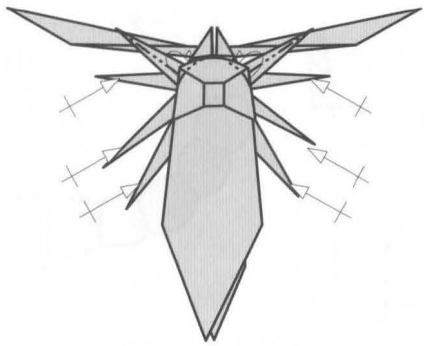

Oreja de conejo en cada pata
Rabbit ear in each leg

89

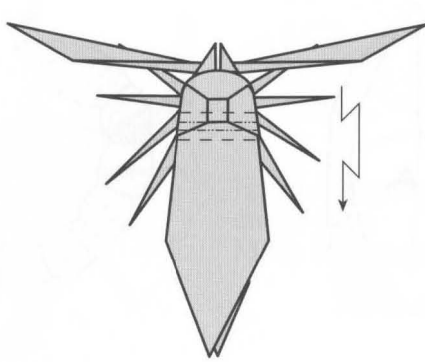

90

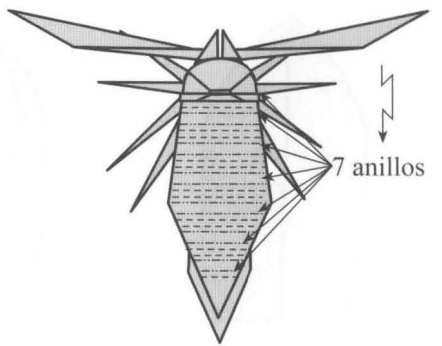

91



92

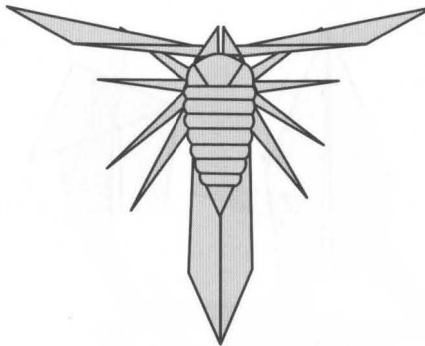

93

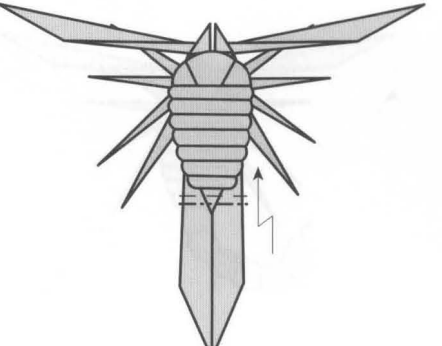

94



95

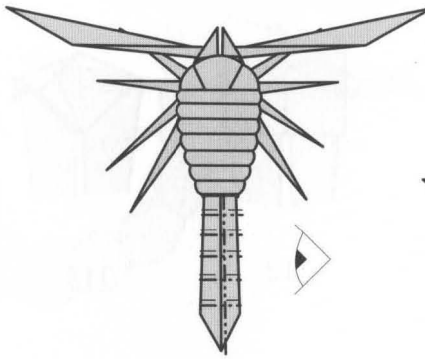

96

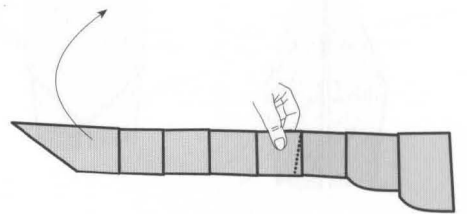

97

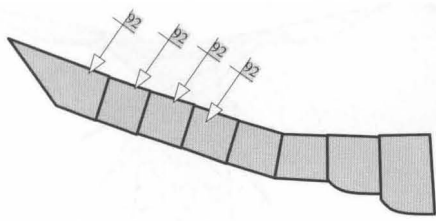

98

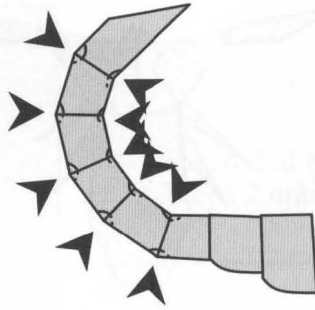

99

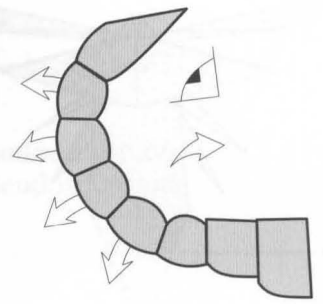

100

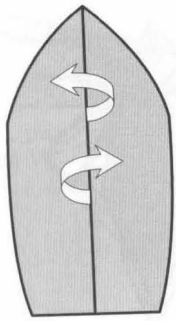

101

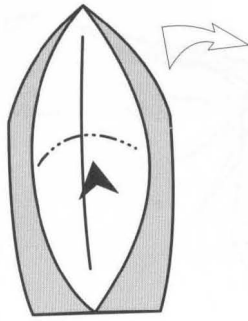

102

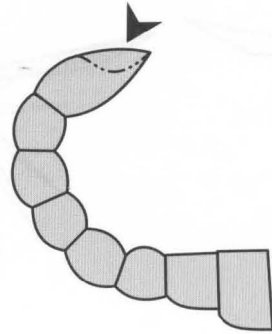

103

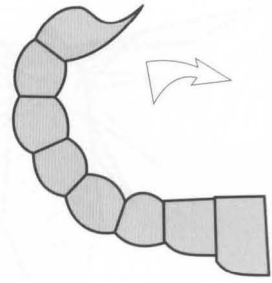

104

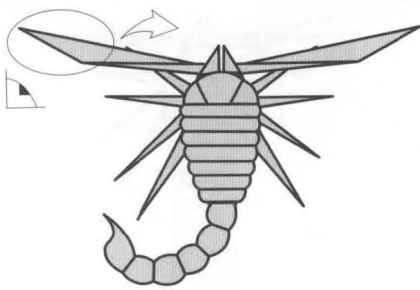

105

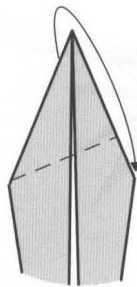

106

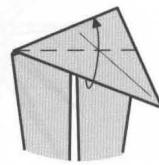

107

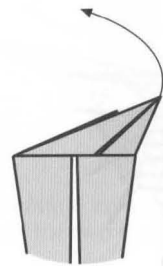

108

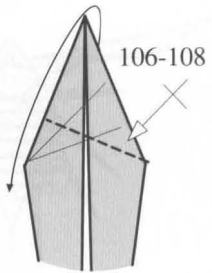

109

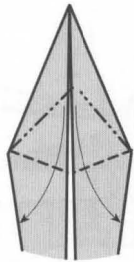

110

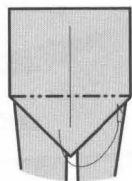

111

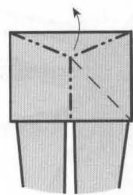

112

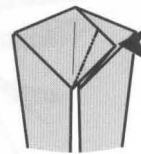

113

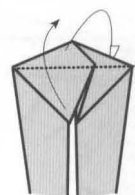

114

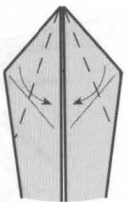

115

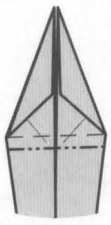

116

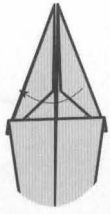

117

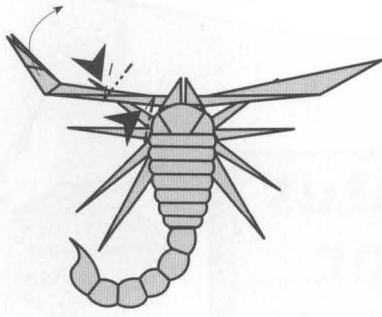

118

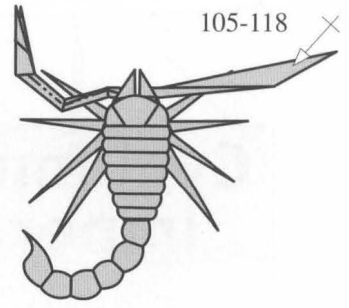

119

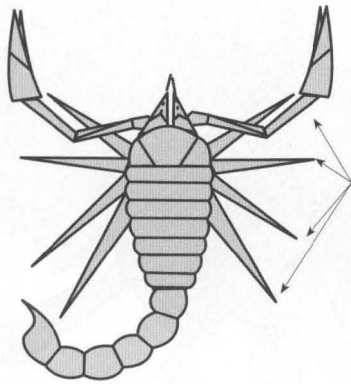

120

Hacer 4 segmentos
en las patas
Make four segments in the legs

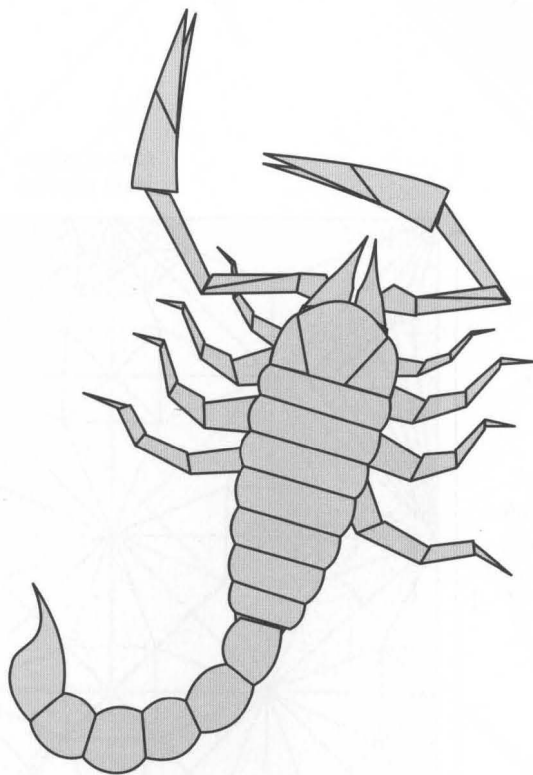

121

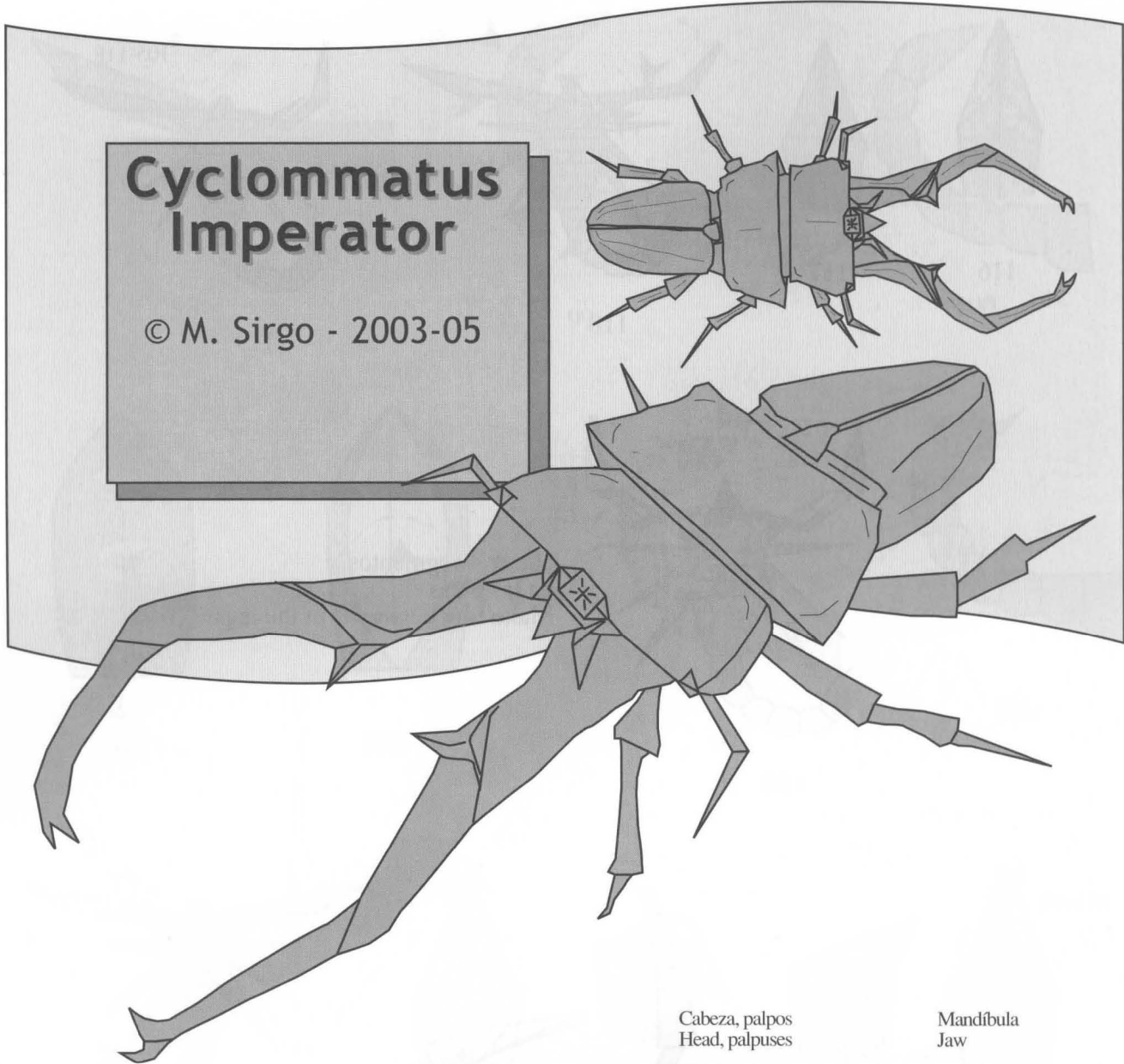

El papel debe ser marrón o verde oscuro. Se recomienda papel fino, menor de 40 gramos, doble seda, banano, lokta, metalizado o *sandwich* de 35x35 cm o mayor.

The paper should be brown or green dark. Fine paper is recommended, smaller than 40 grams, double silk, banana tree, lokta, metalized or *sandwich* of 35x35 cm or bigger.

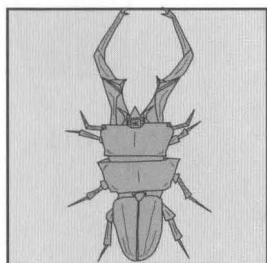

2/5

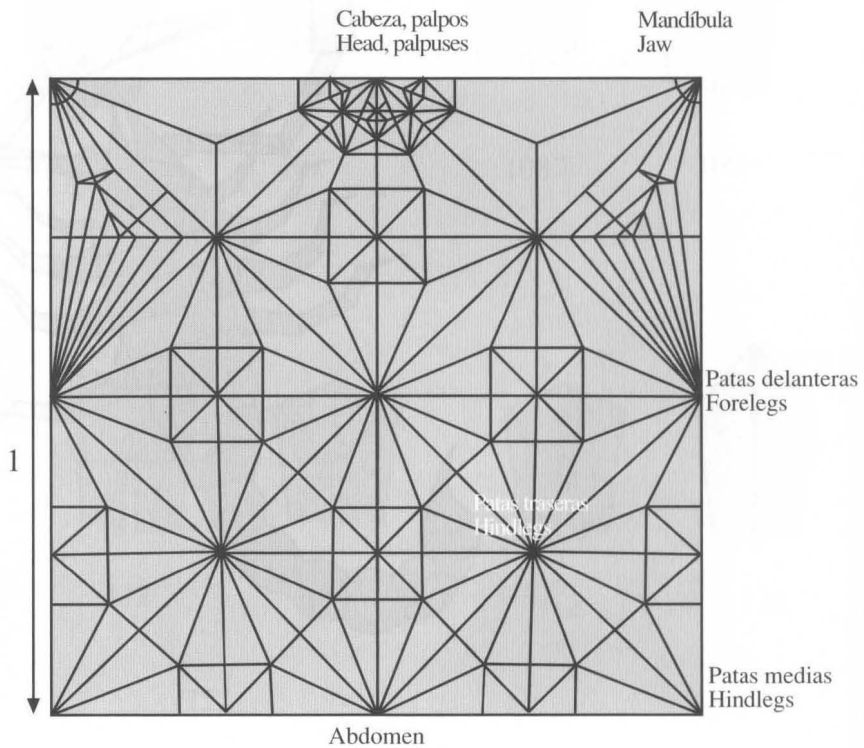

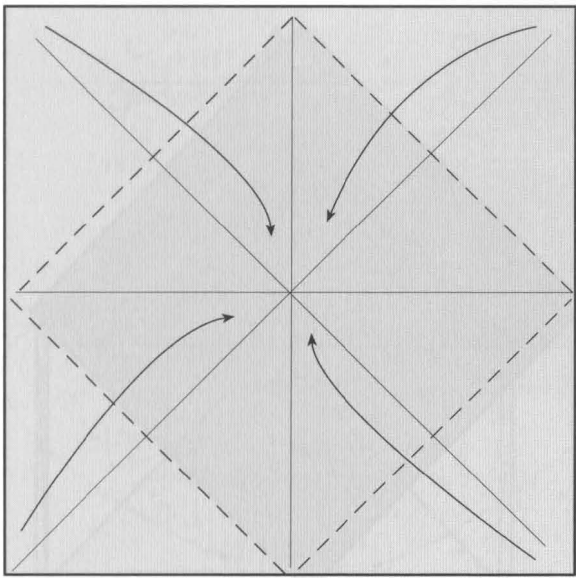

1 

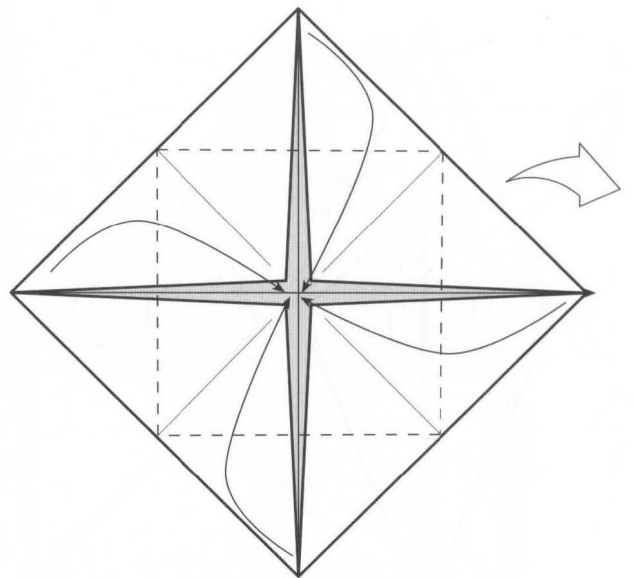

2

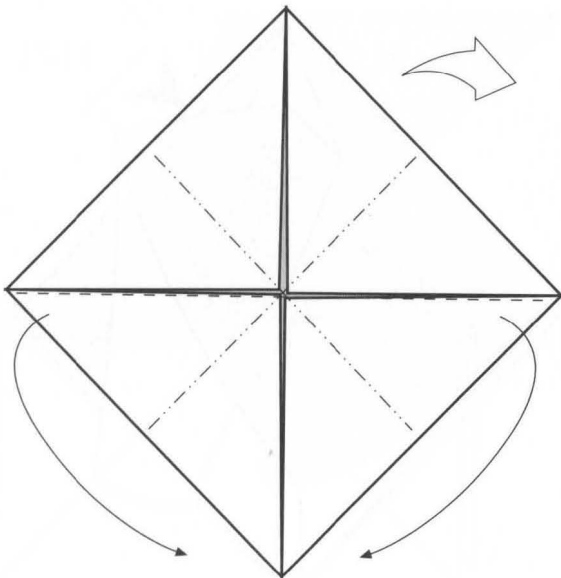

3

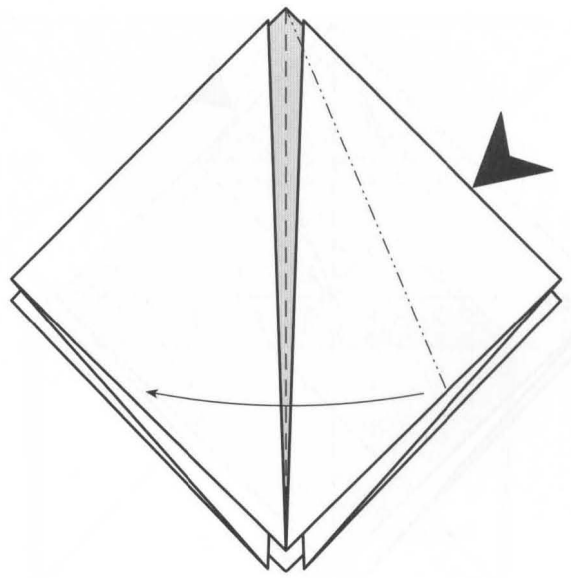

4

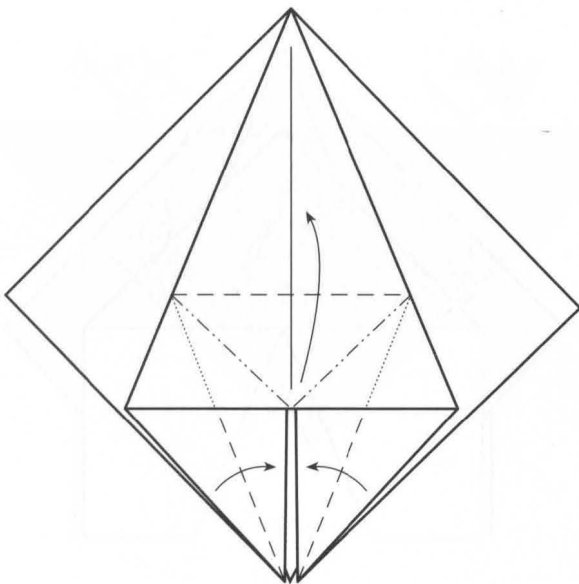

5

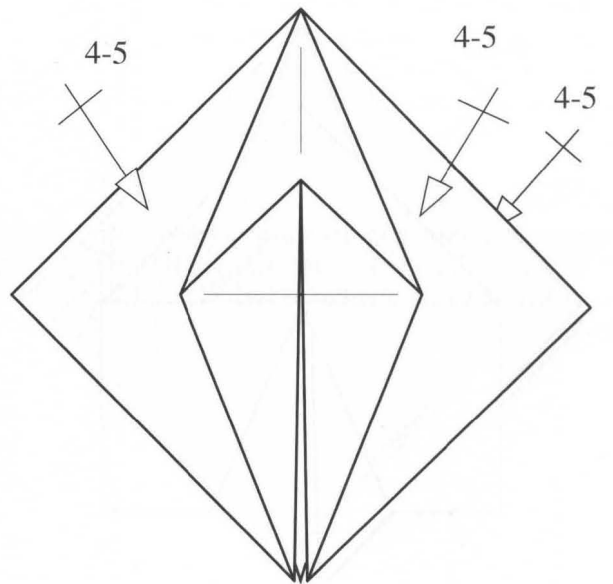

6

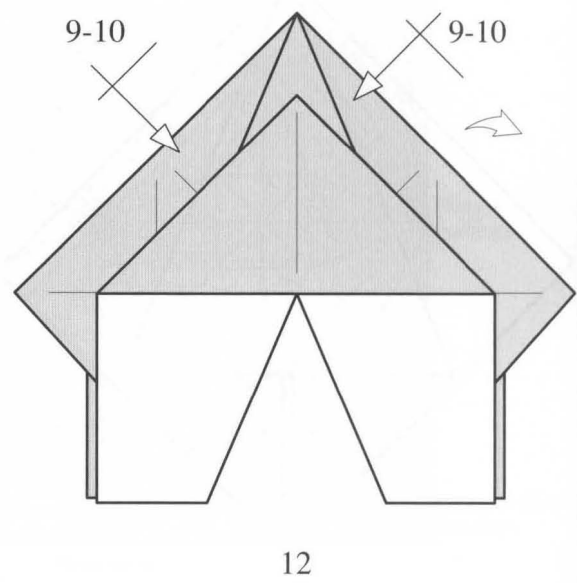
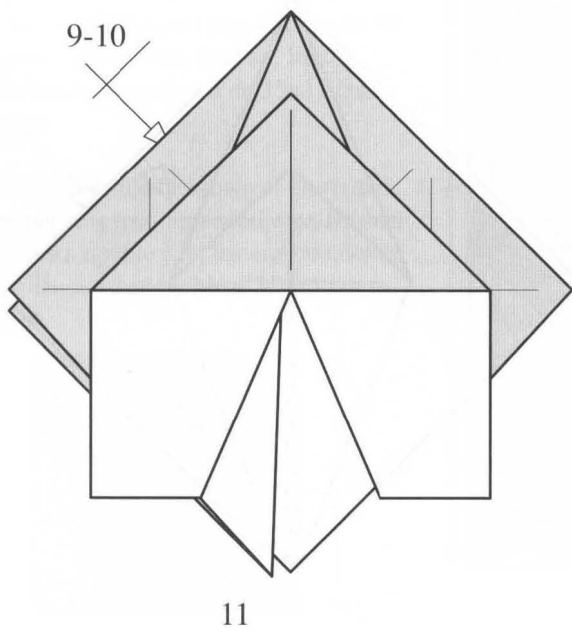
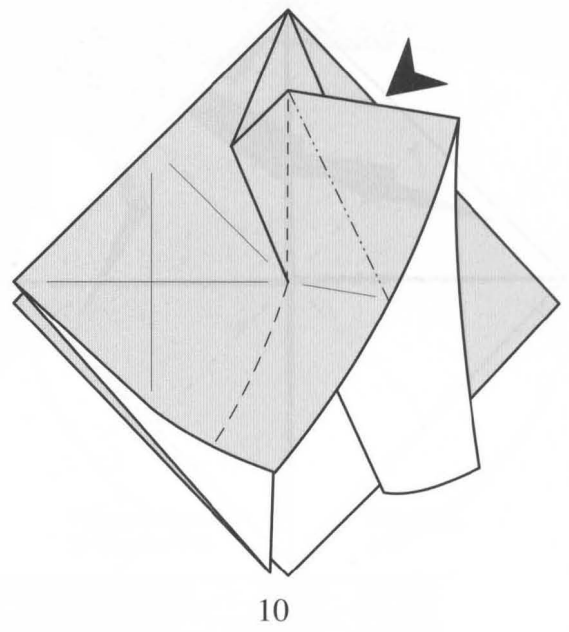
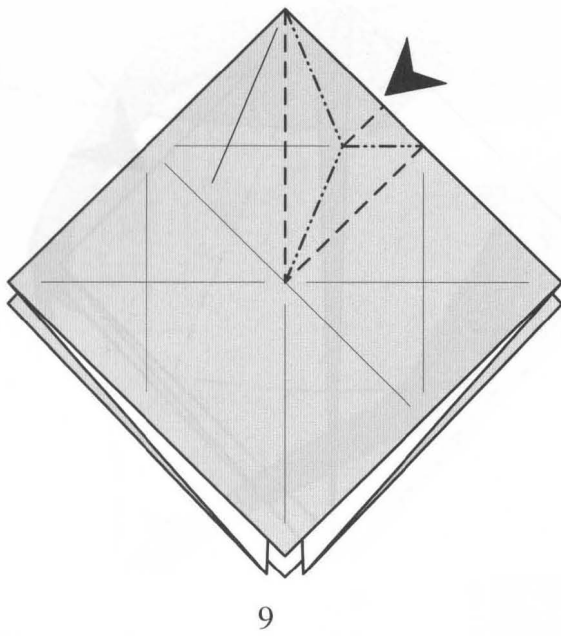
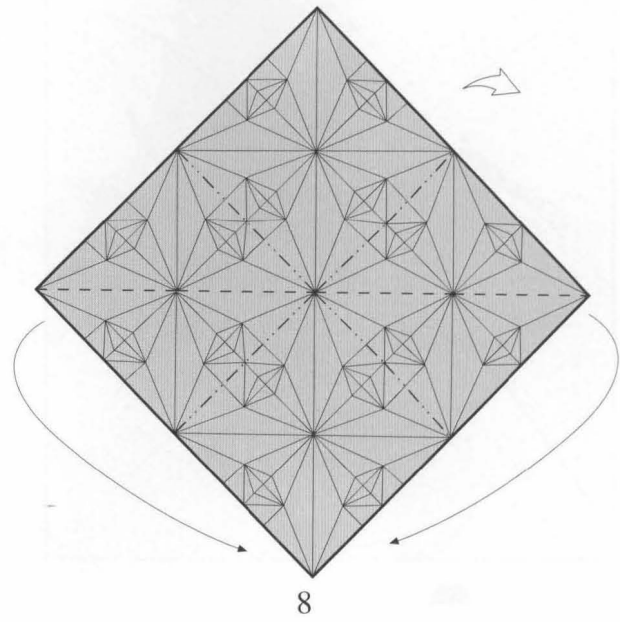
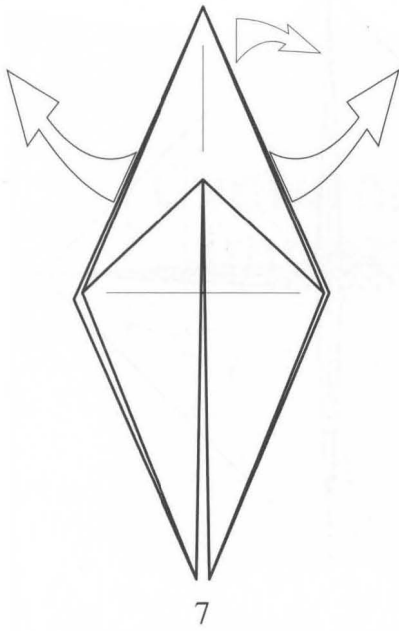

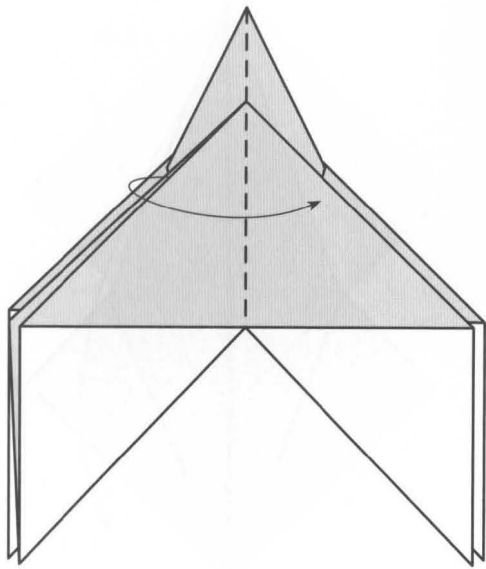

13

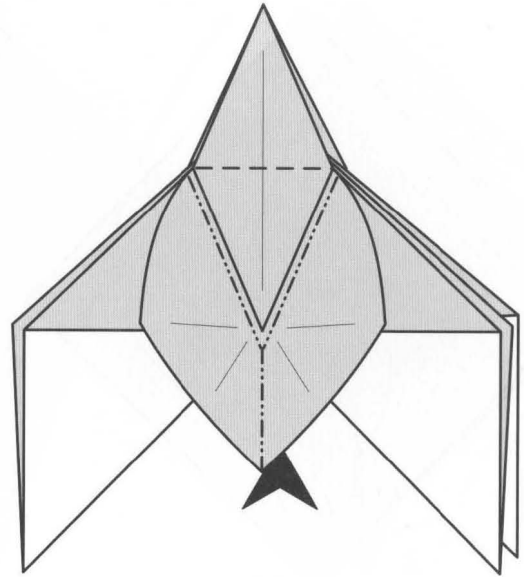

14

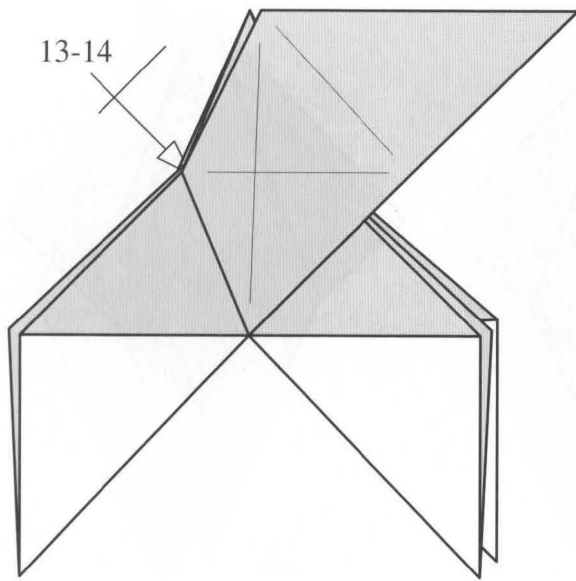

15

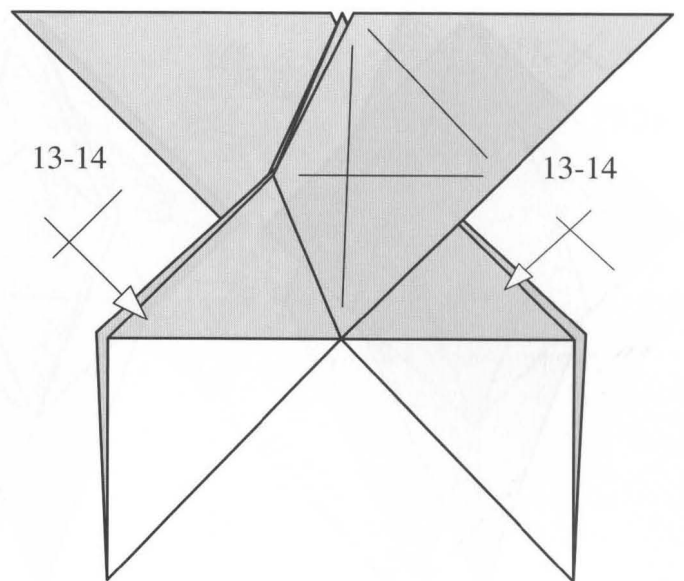

16

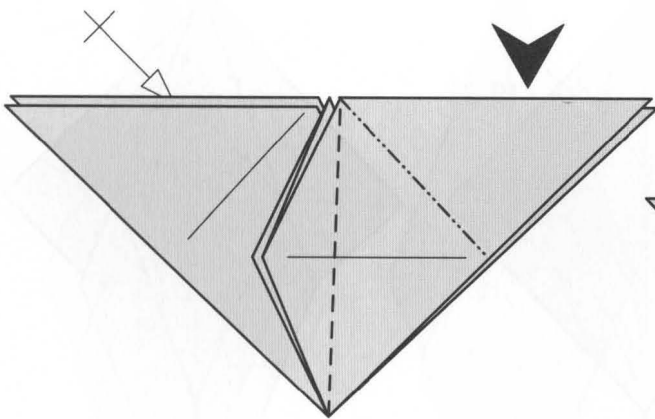

17

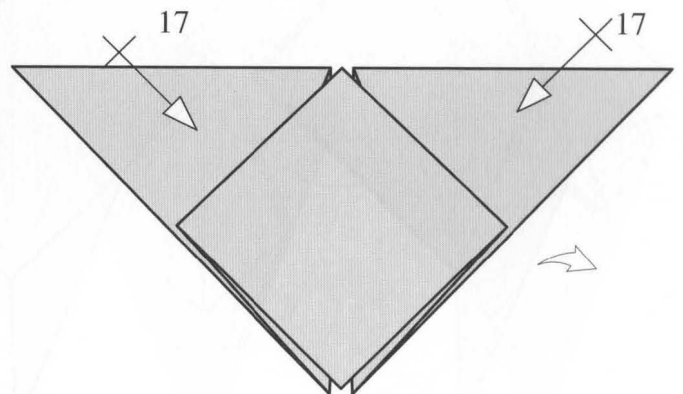

18

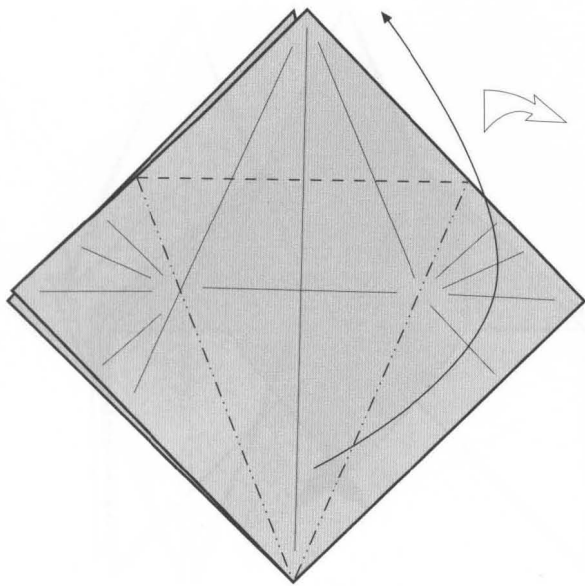

19

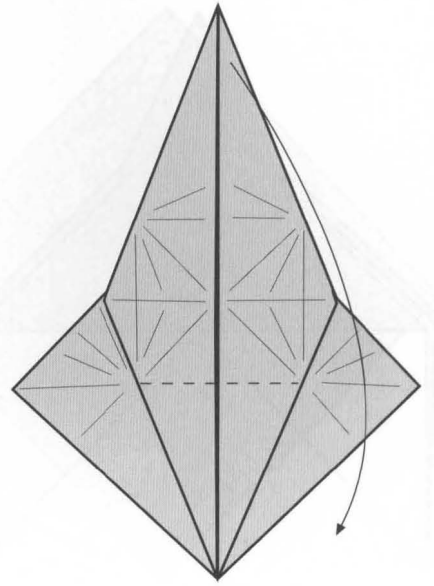

20

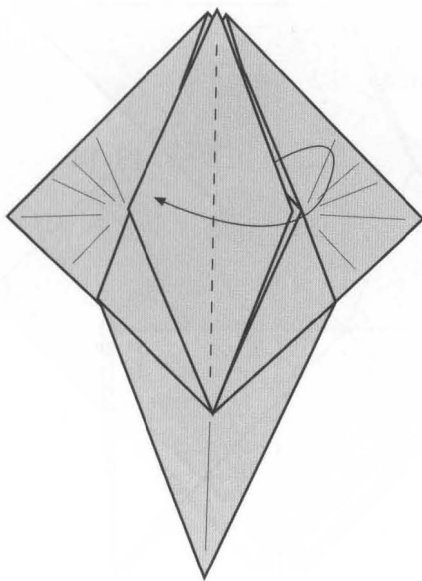

21

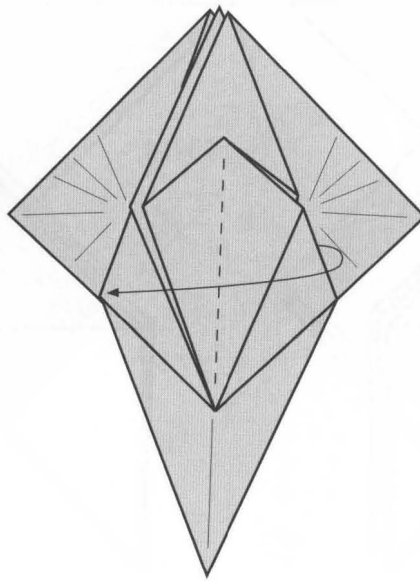

22

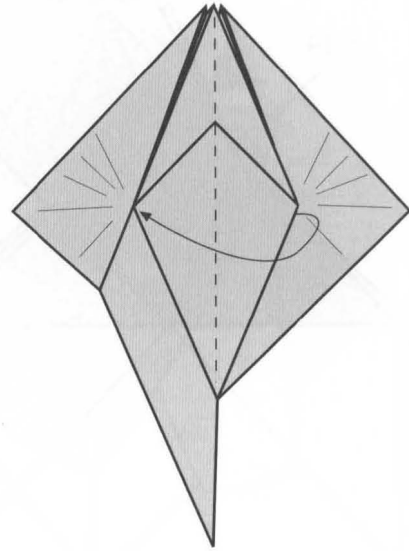

23

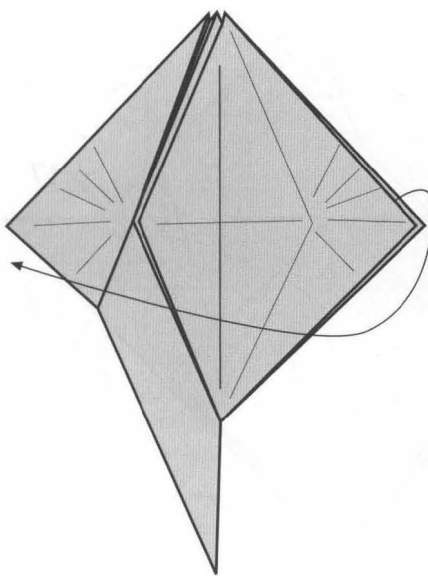

24

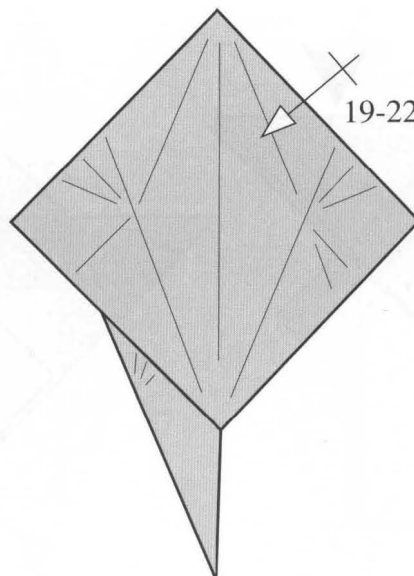

25

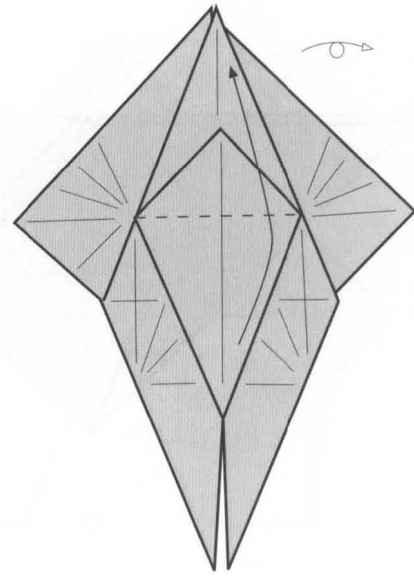

26

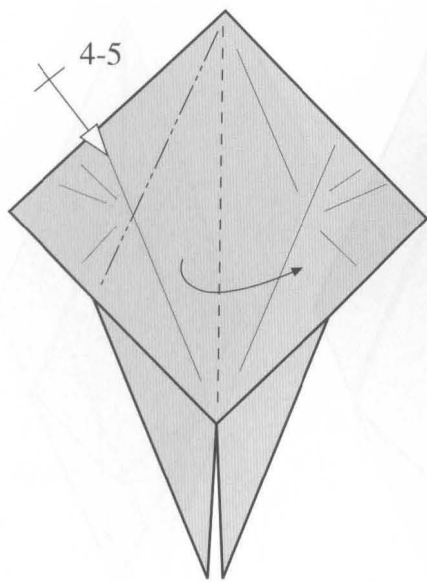

27

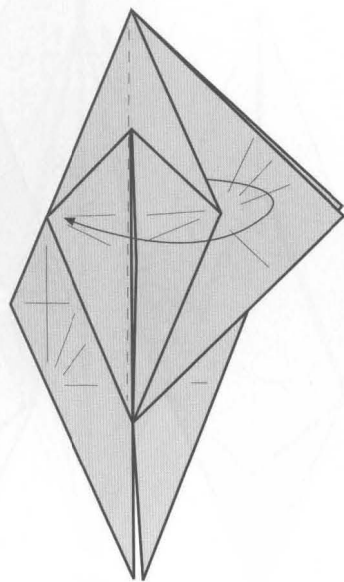

28

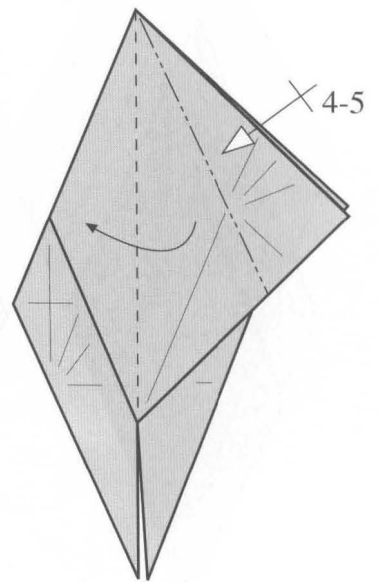

29

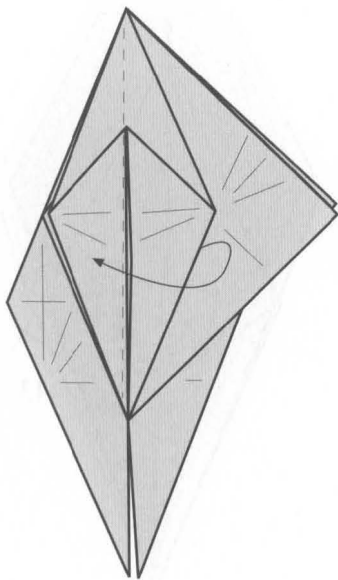

30

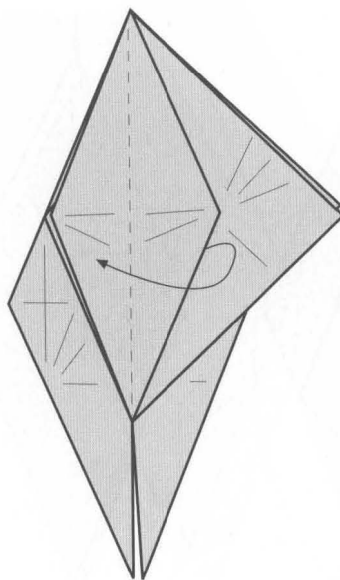

31

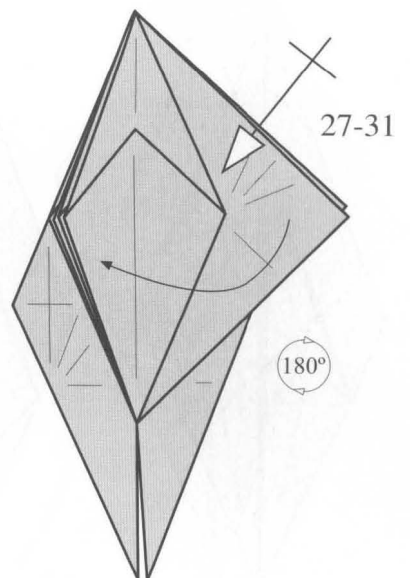

32

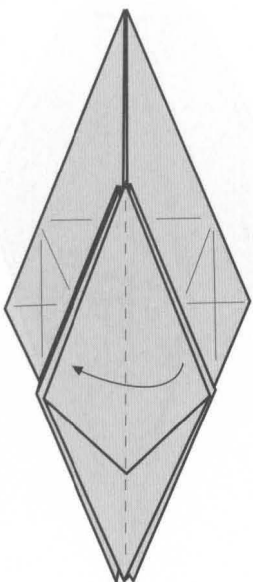

33

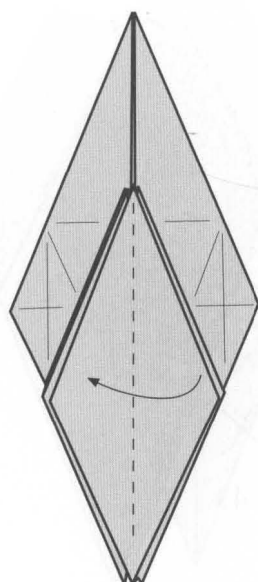

34

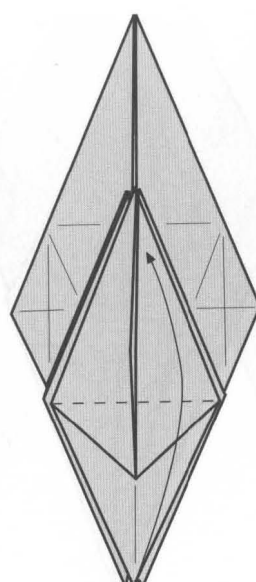

35

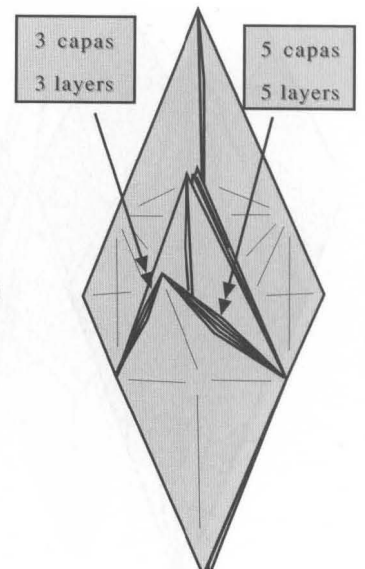

36 -3D

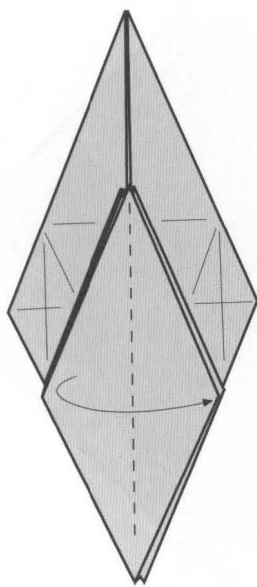

37

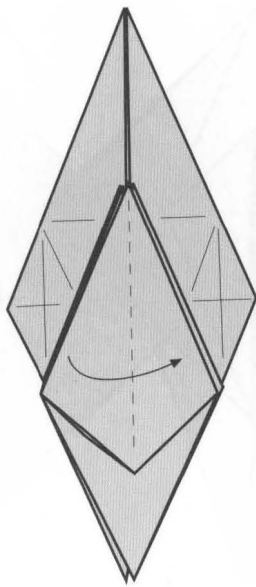

38

33-38

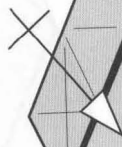

39

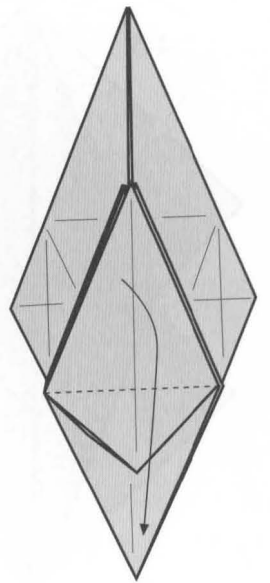

40

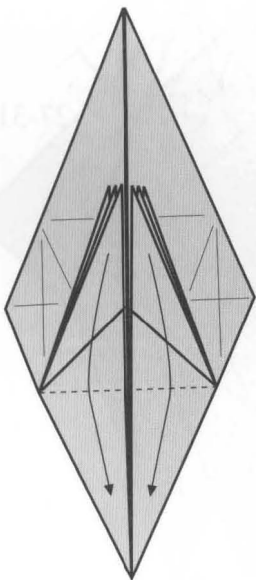

41

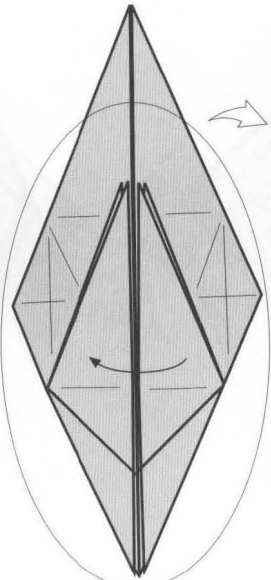

42

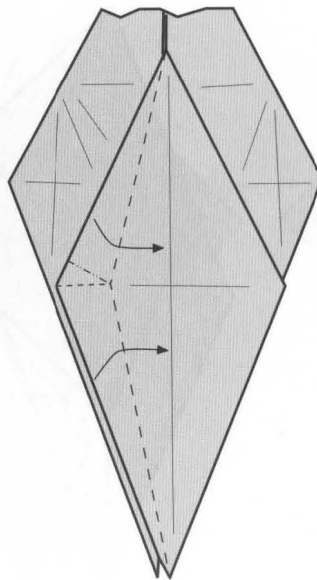

43

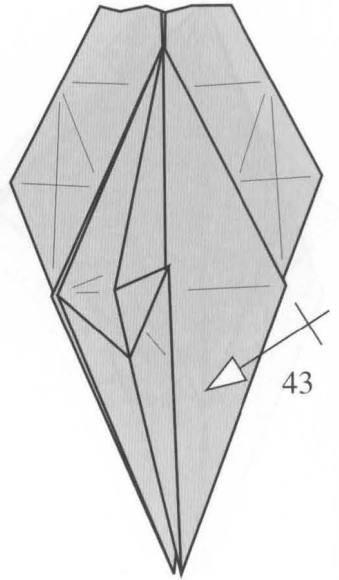

44

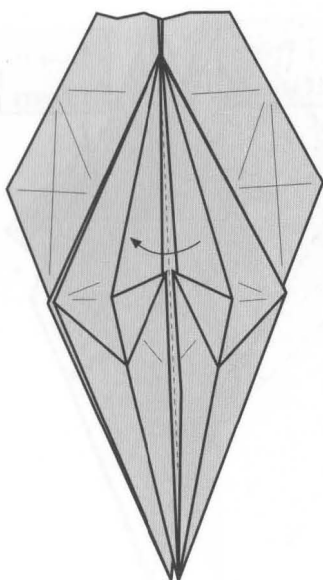

45

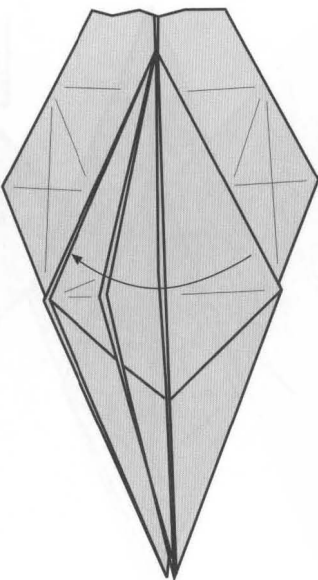

46

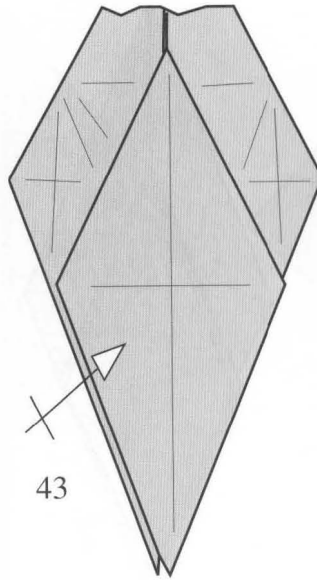

43

47

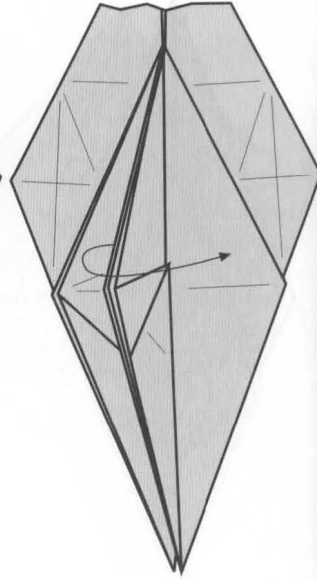

48

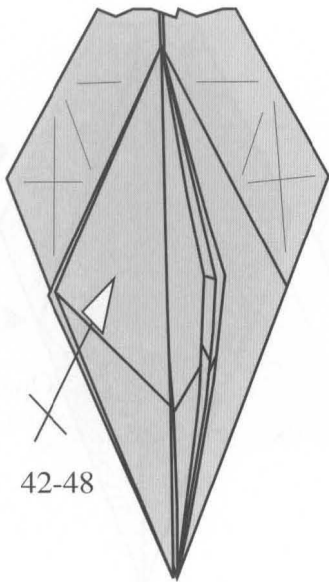

42-48

49

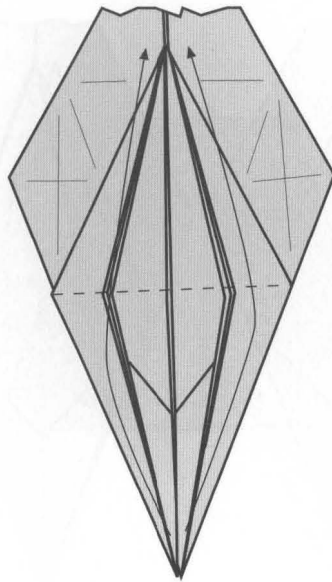

50

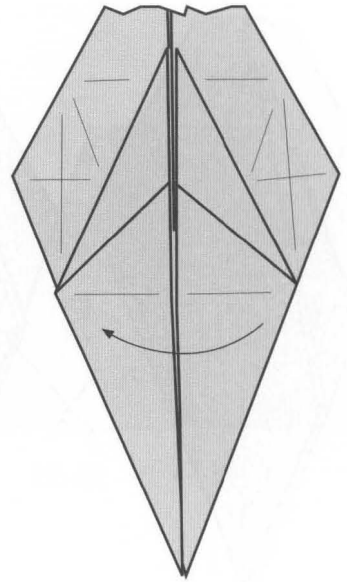

51

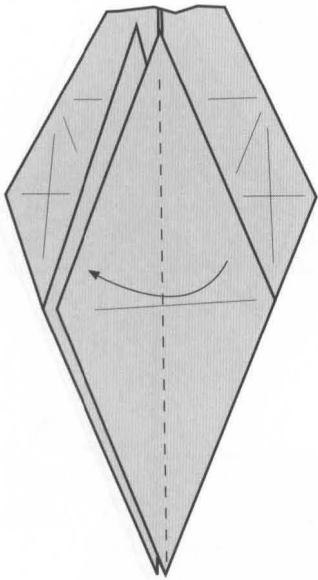

52

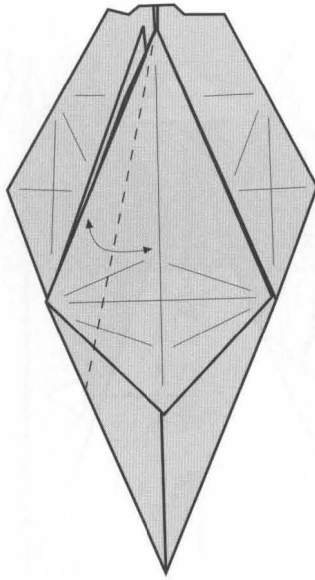

53

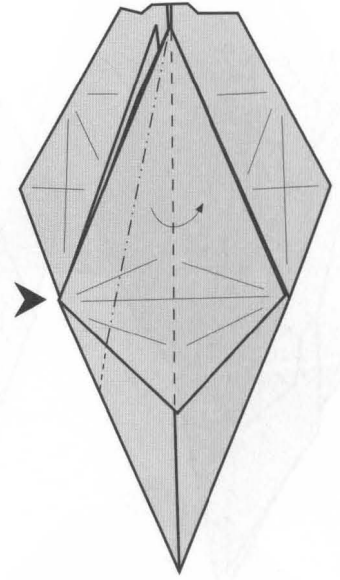

54

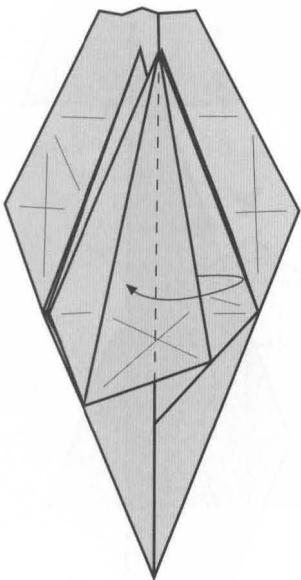

55

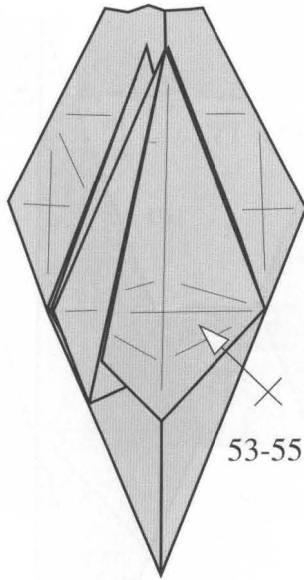

53-55

56

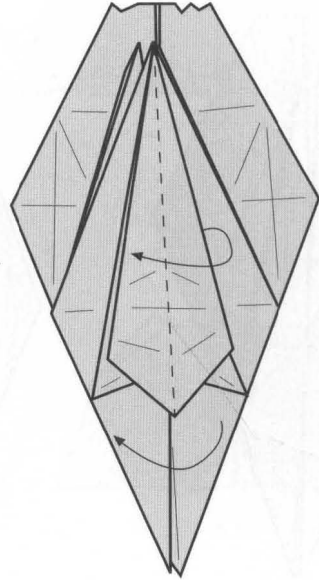

57

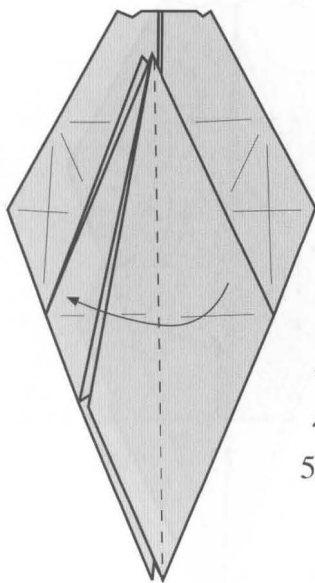

58

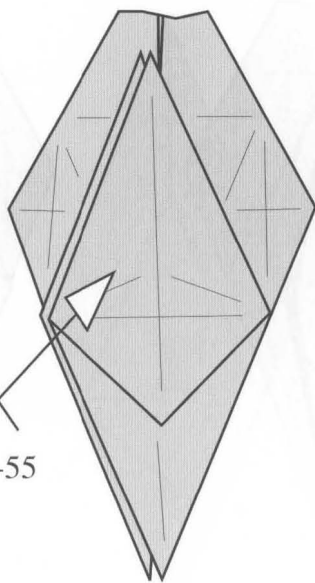

53-55

59

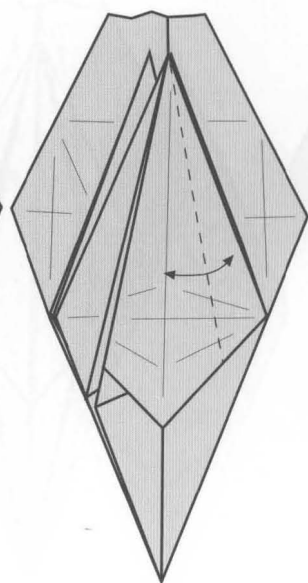

60

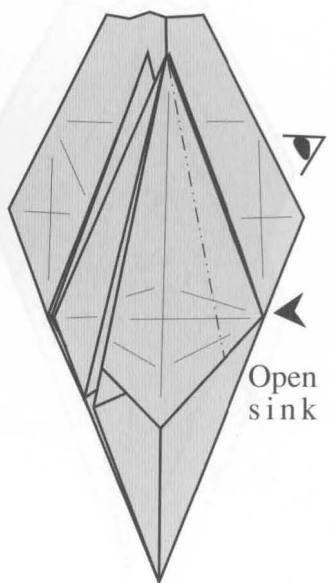

Open sink

61

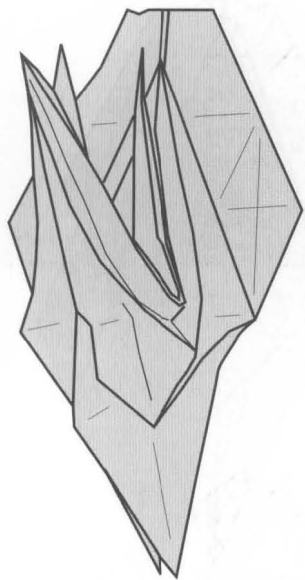

62

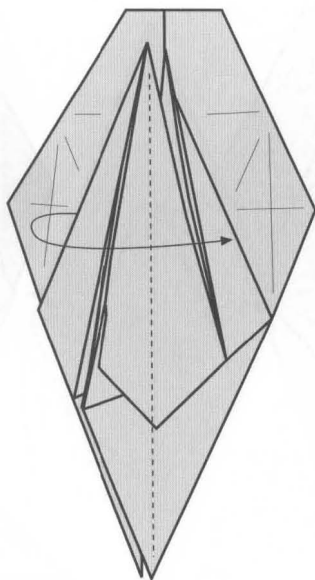

63

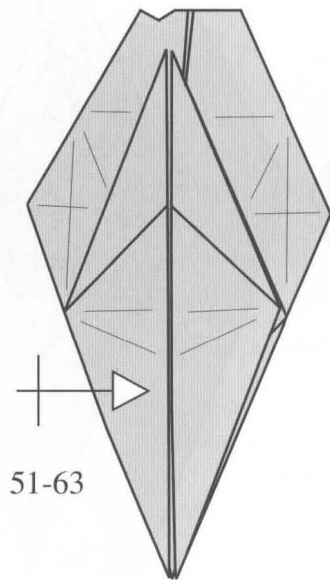

51-63

64

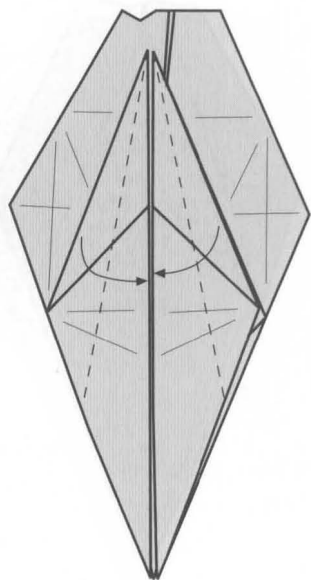

65

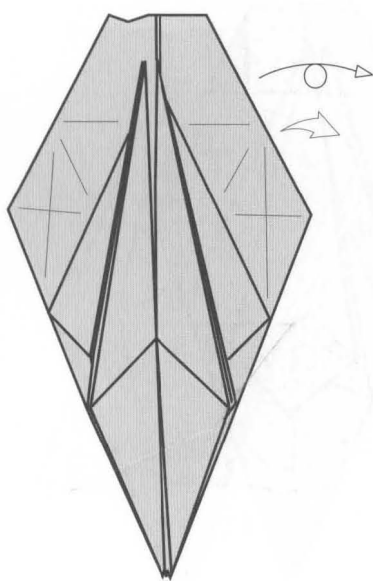

66

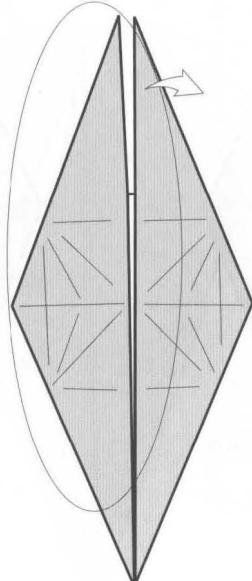

67

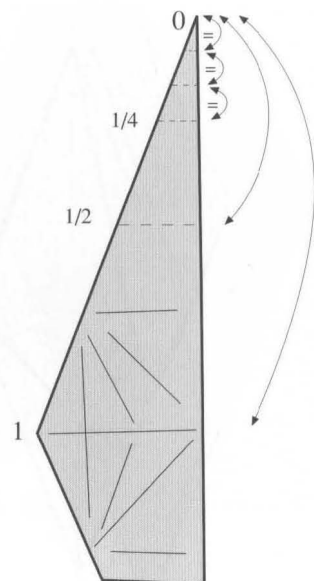

68

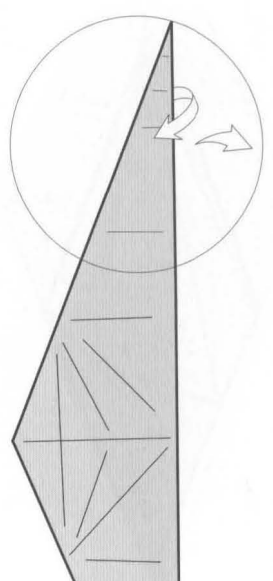

69

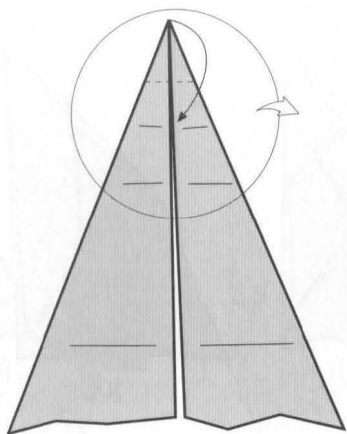

70

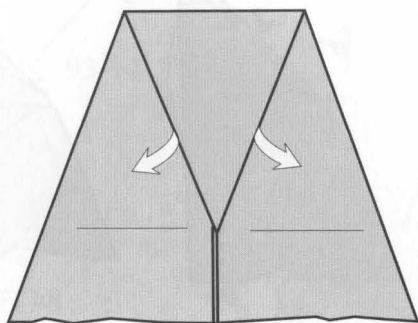

71

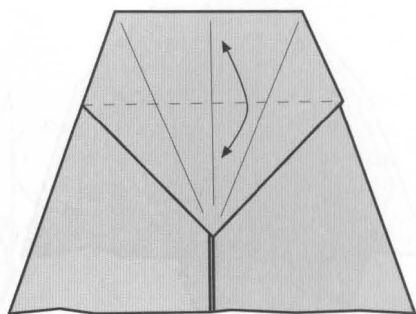

72

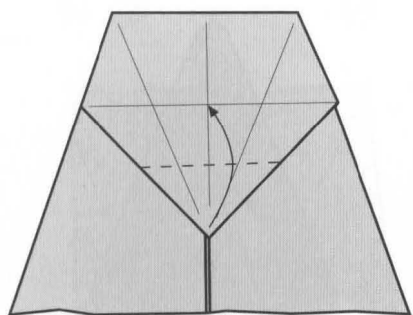

73

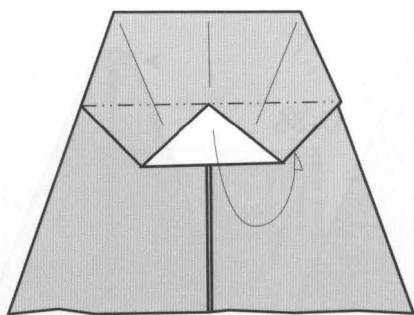

74

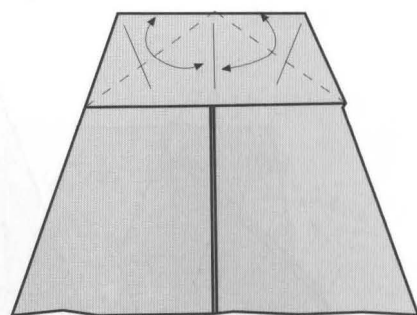

75

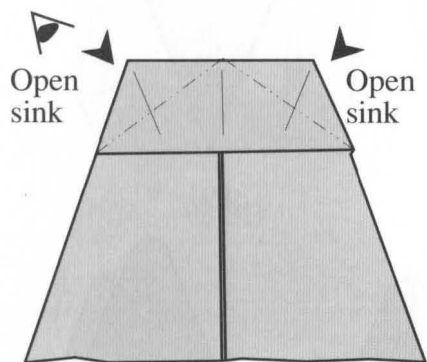

76

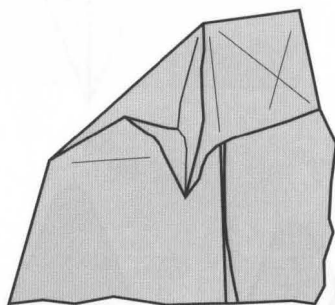

77-3D

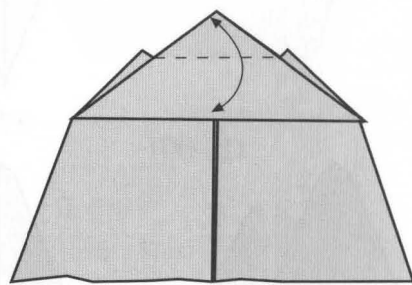

78

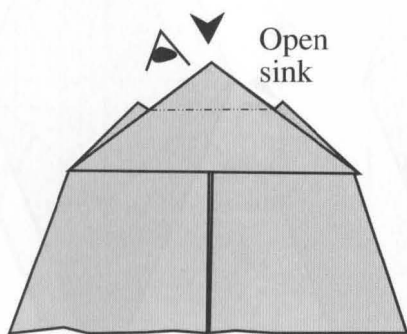

79

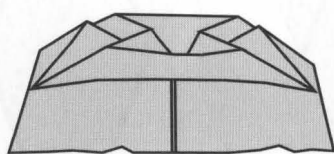

80-3D

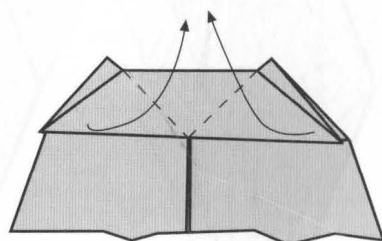

81

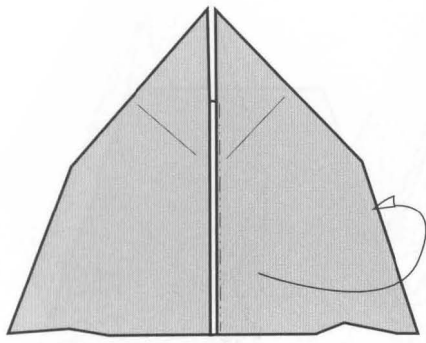

82

Estirar
Strecht

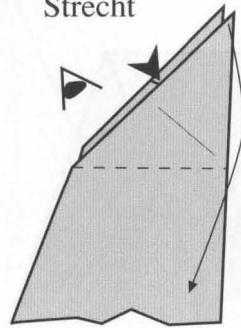

83

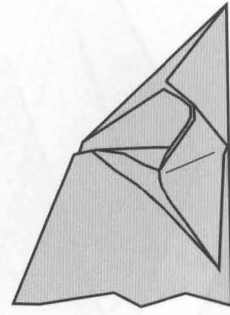

84-3D

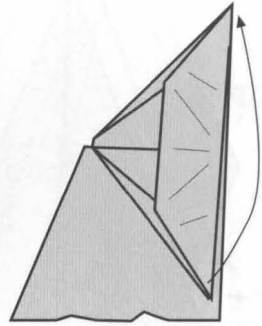

85

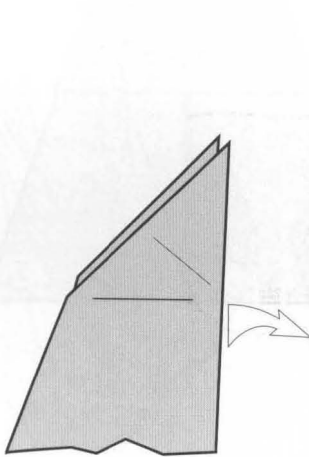

86

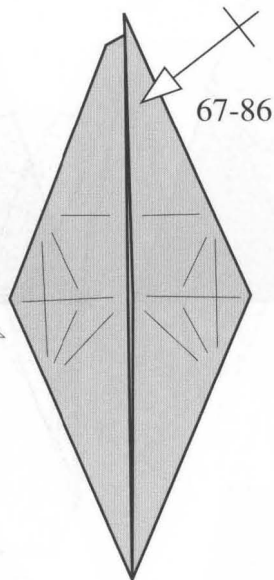

87

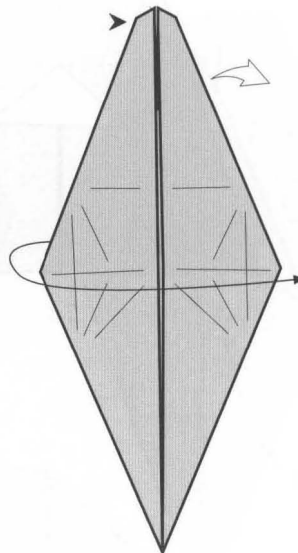

88

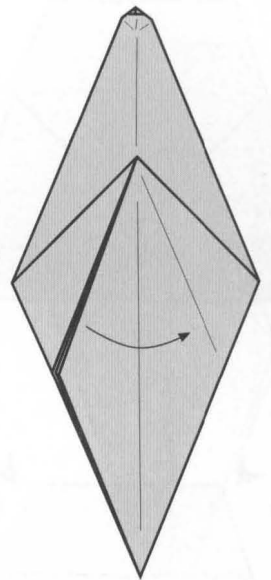

89

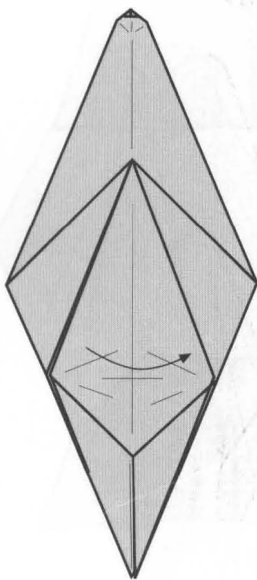

90

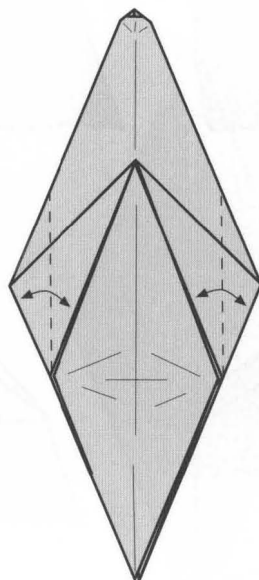

91

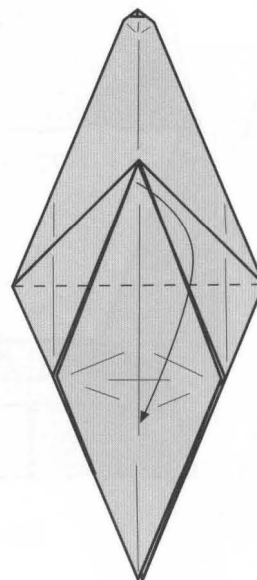

92

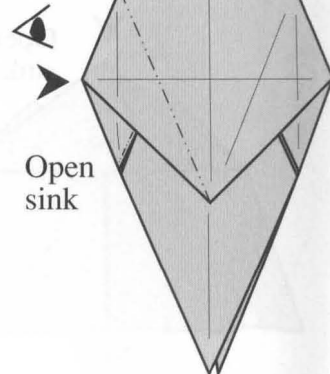

93

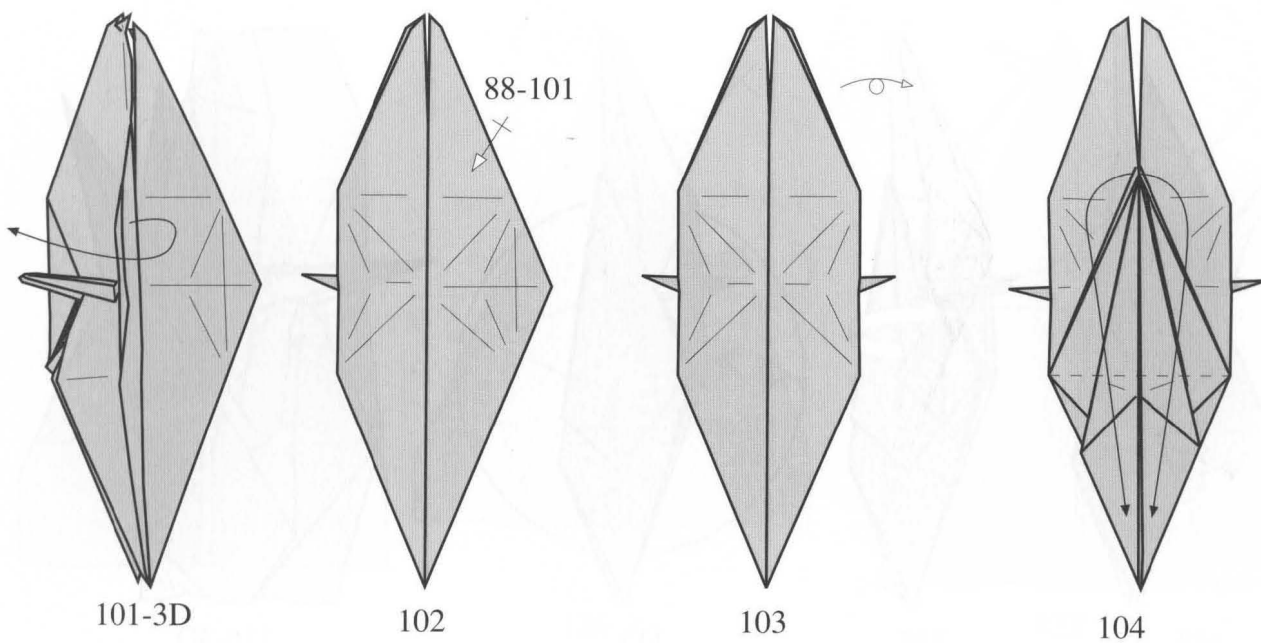
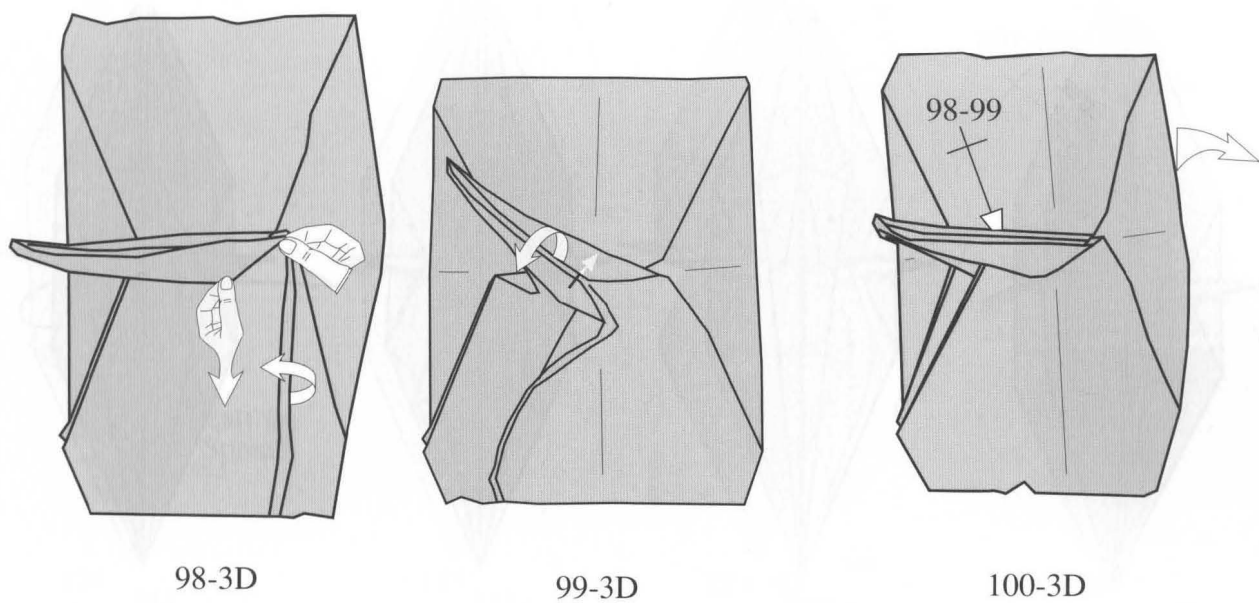
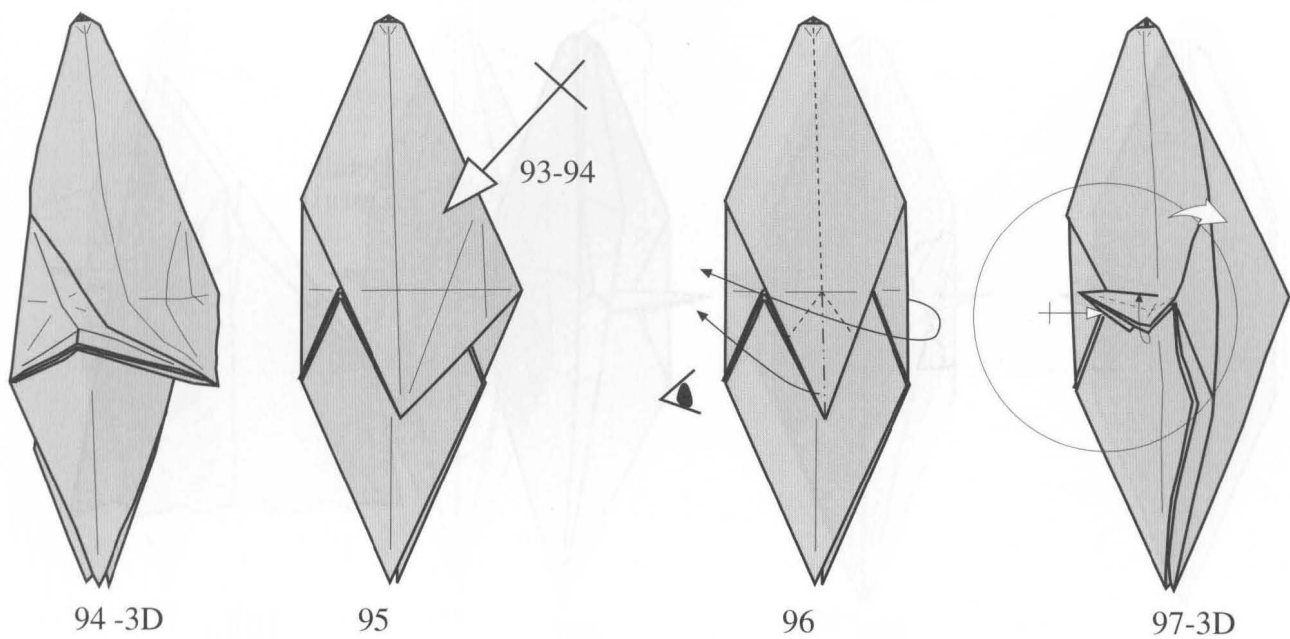

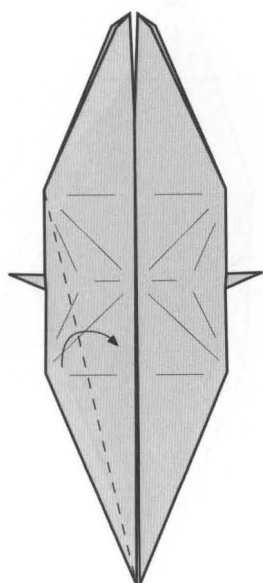

105

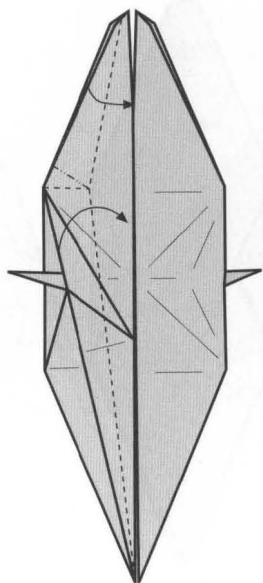

106

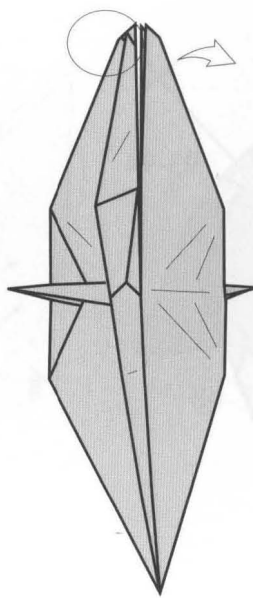

107

Detalle
Detail

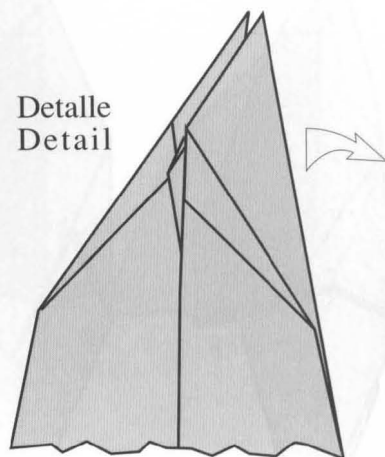

108

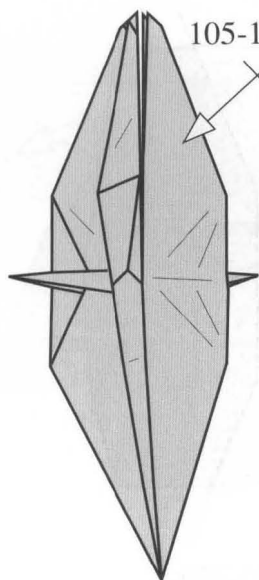

109

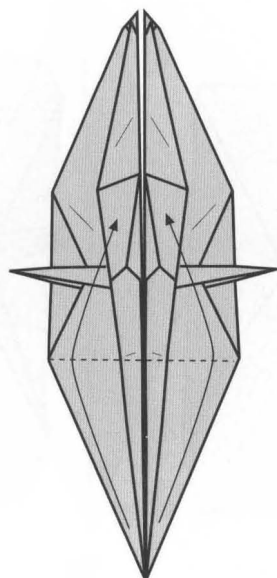

110

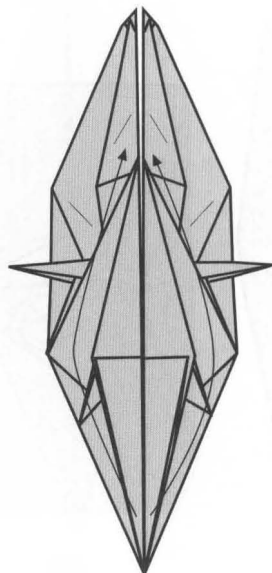

111

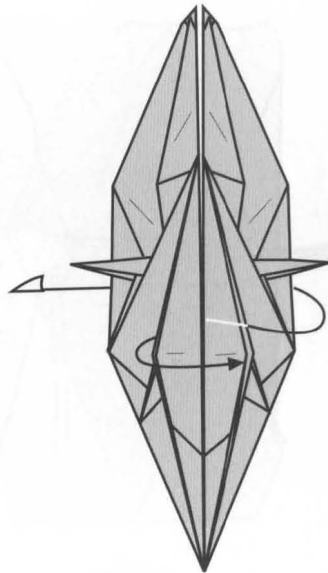

112

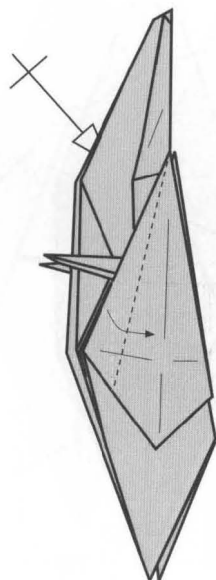

113

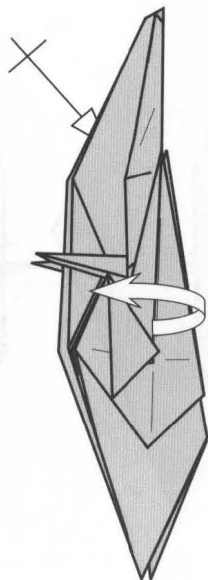

114

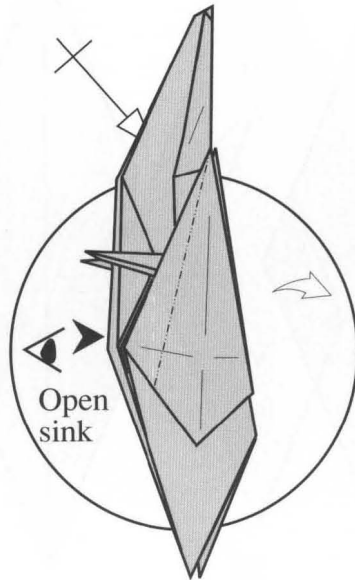

115

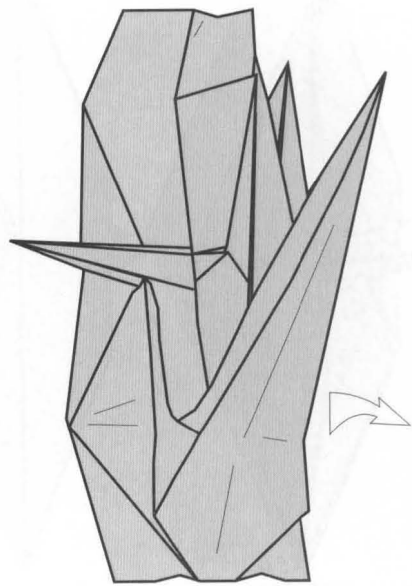

116-3D

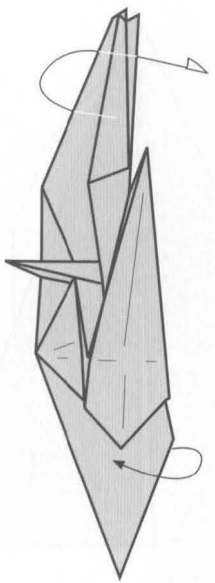

117

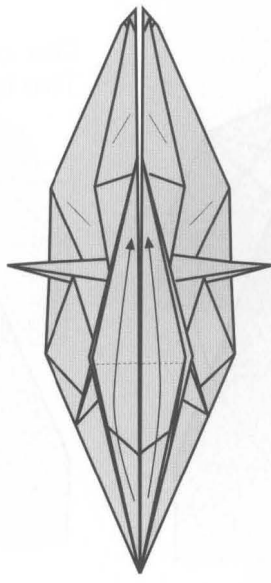

118

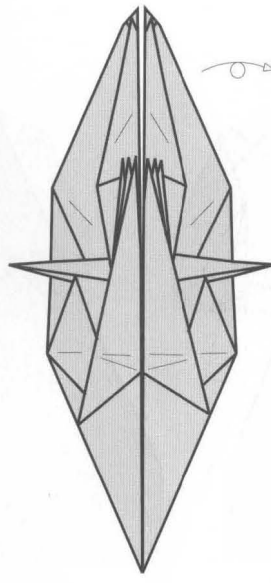

119

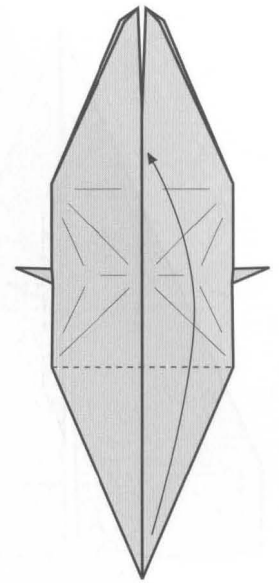

120

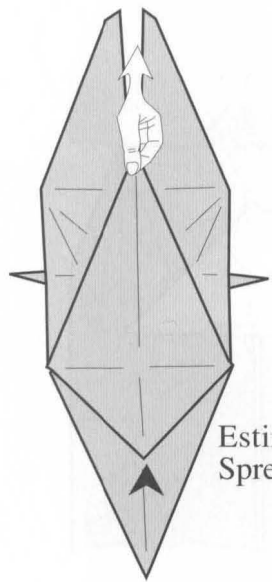

Estirar
Spread

121

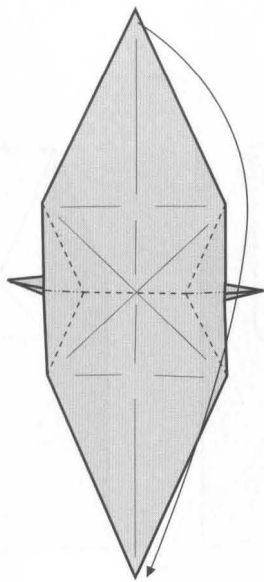

122

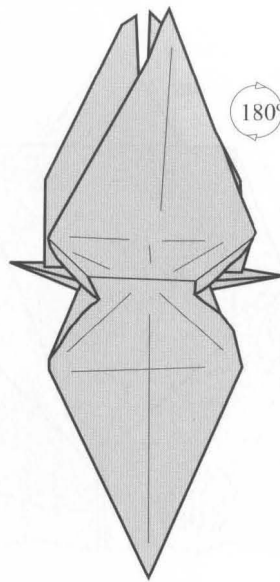

123-3D

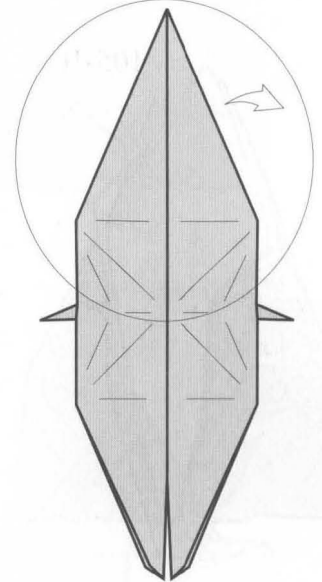

124

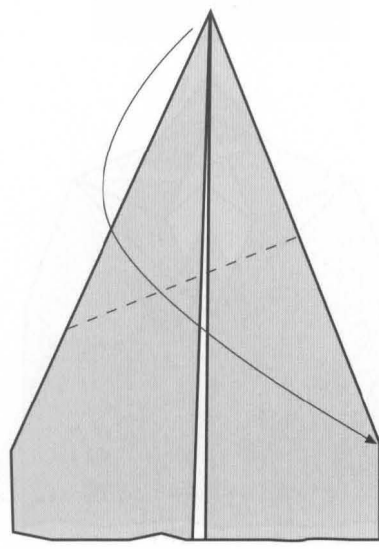

125

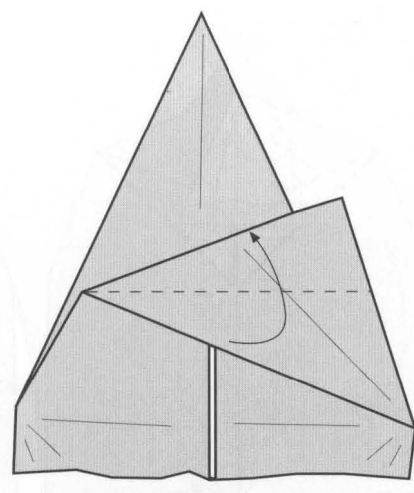

126

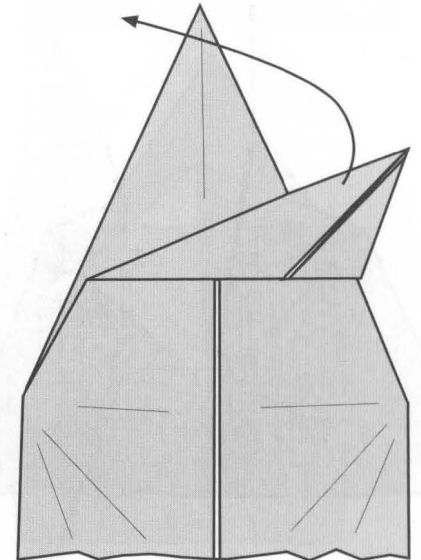

127

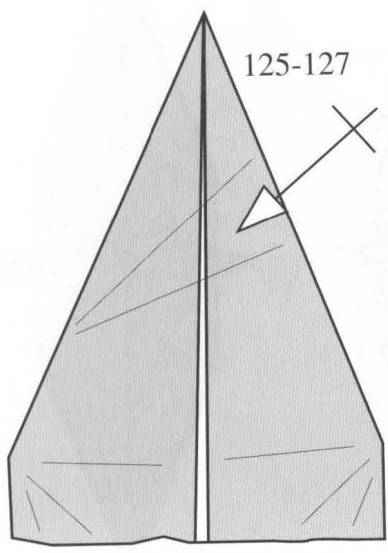

128

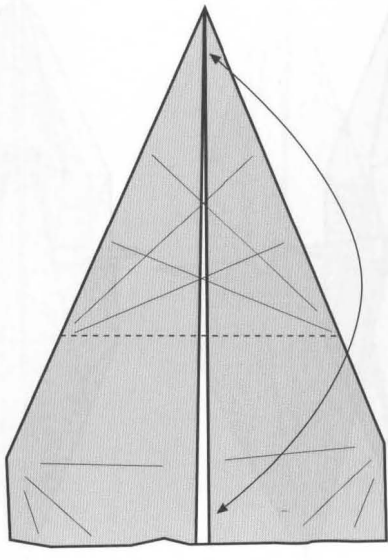

129

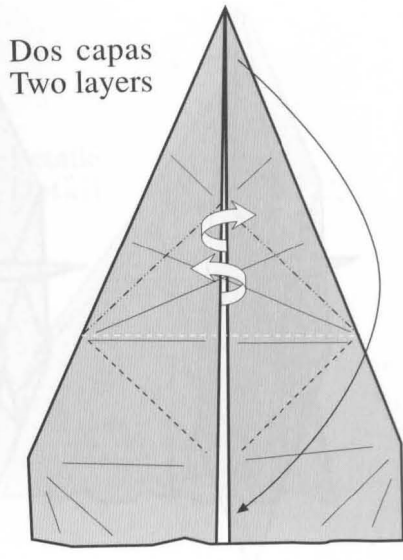

130

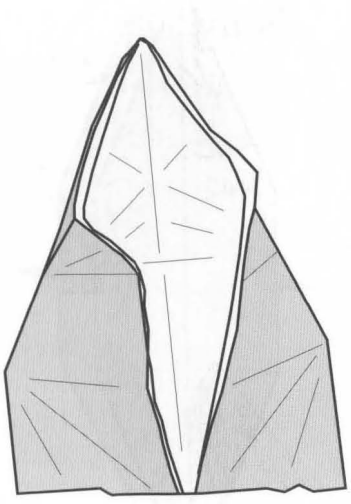

131-3D

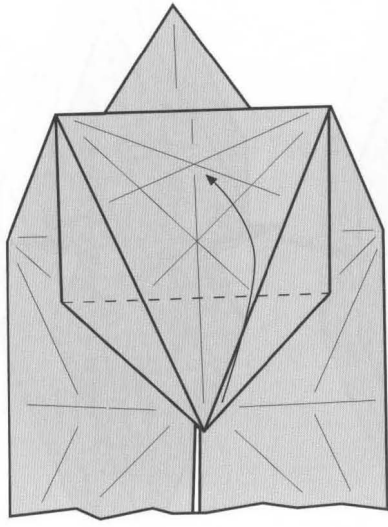

132

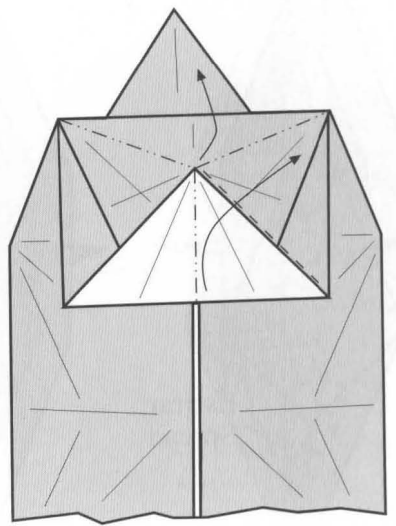

133

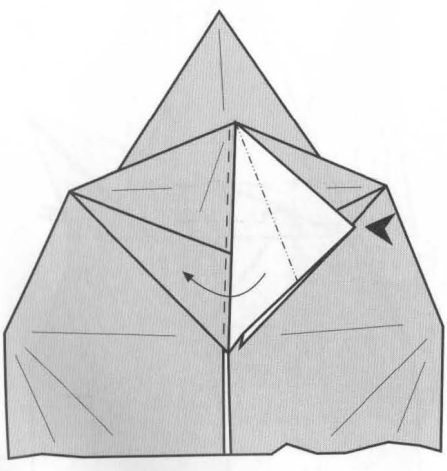

134

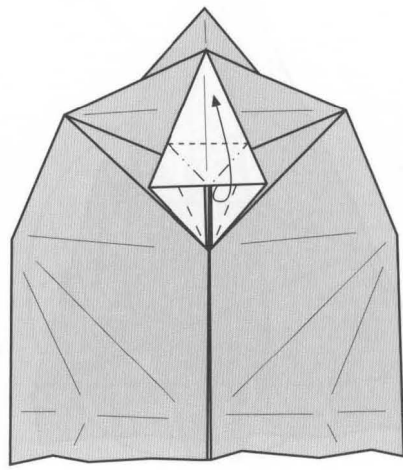

135

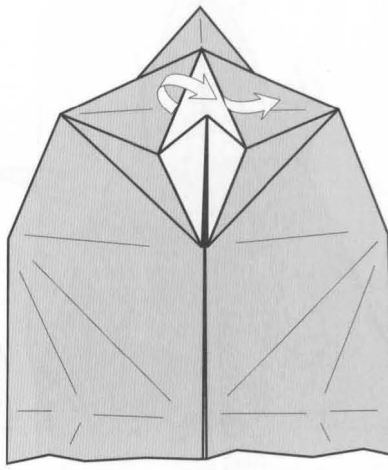

136

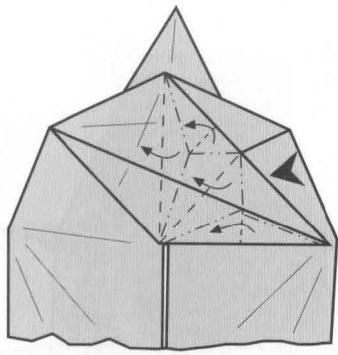

137

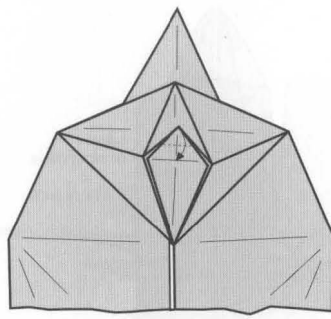

138

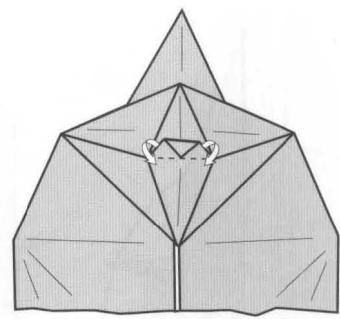

139

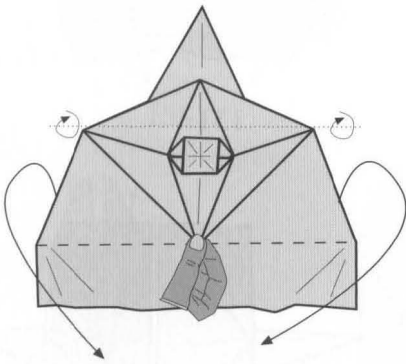

140

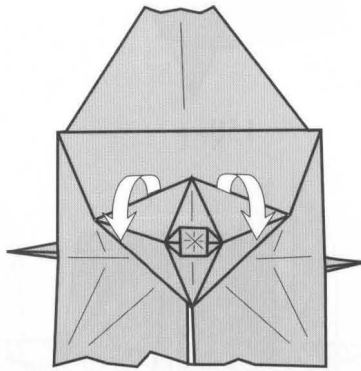

141

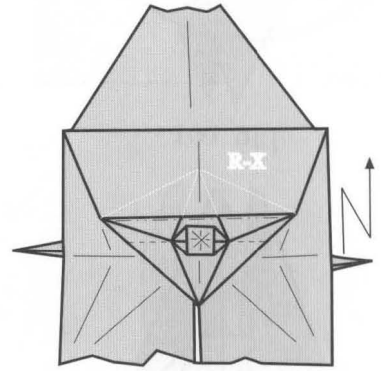

142

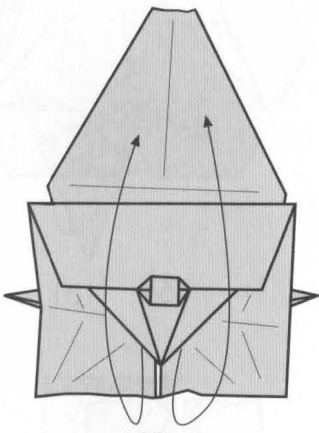

143

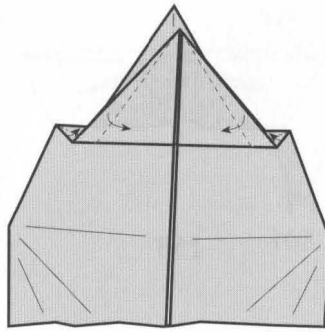

144

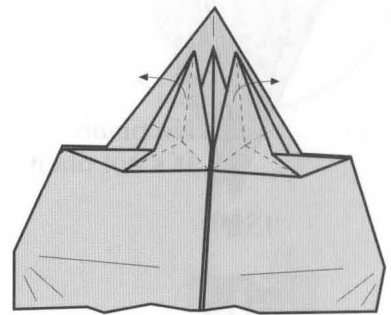

145

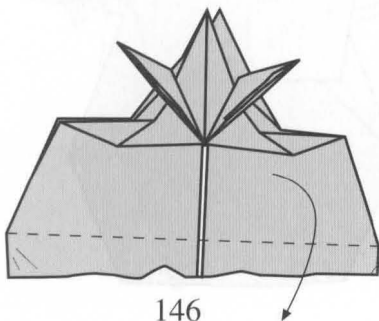

146

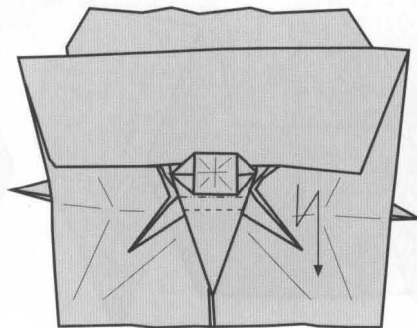

147

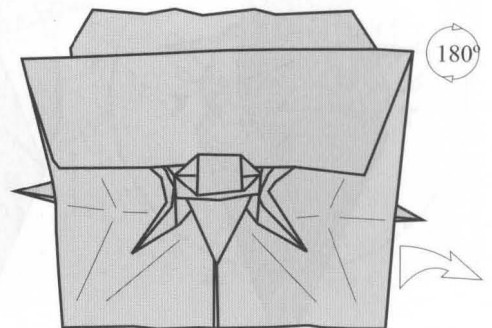

148

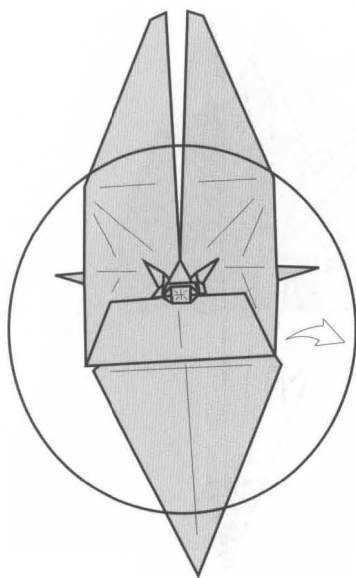

149

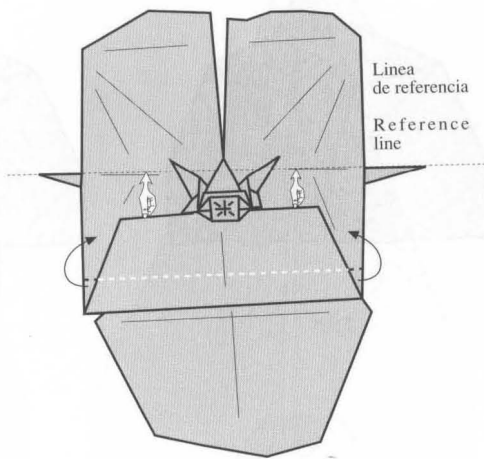

150

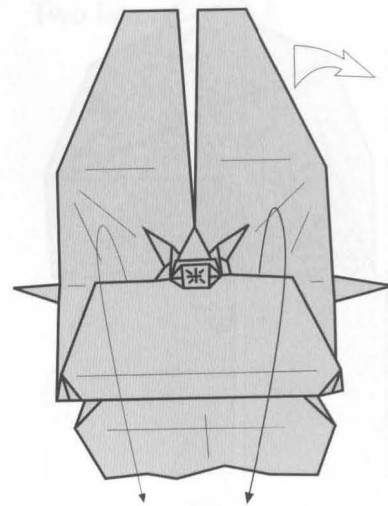

151

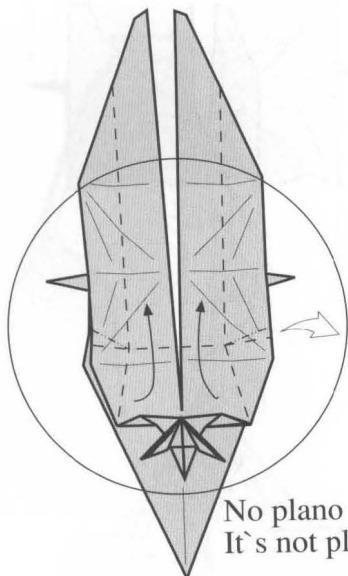

152

No plano
It's not plain

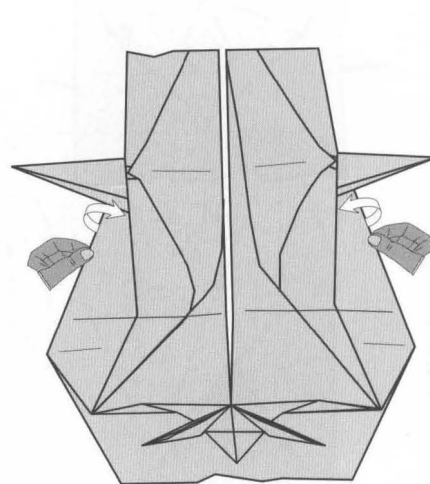

153

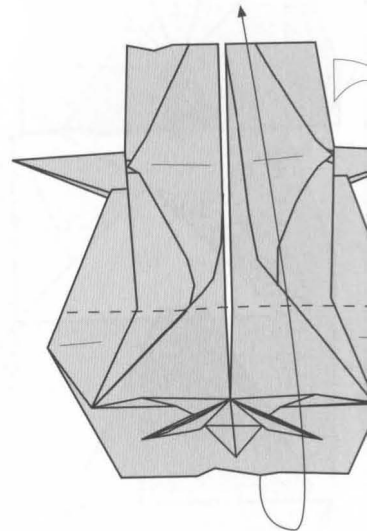

154

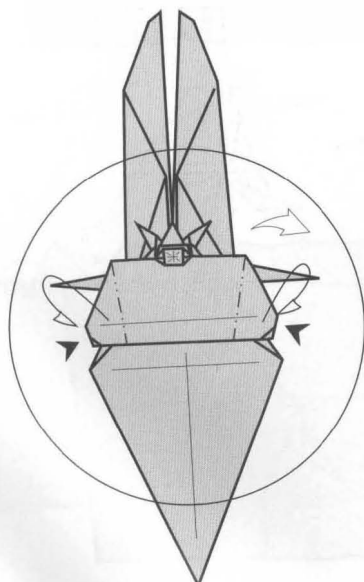

155

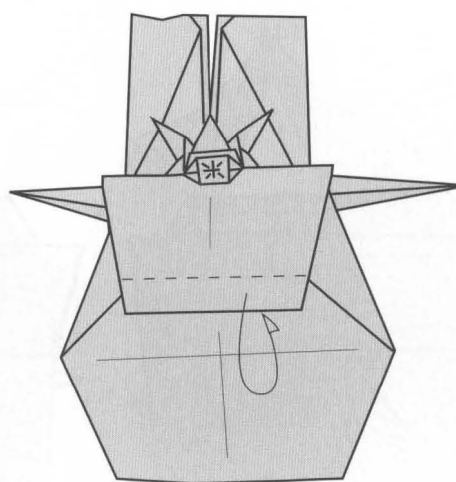

156

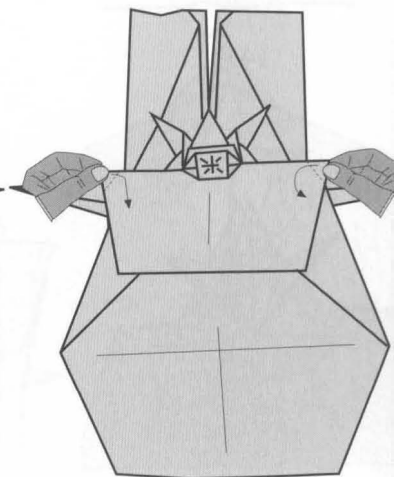

157

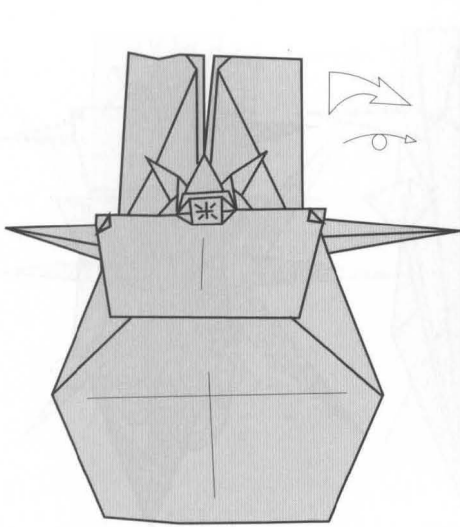

158

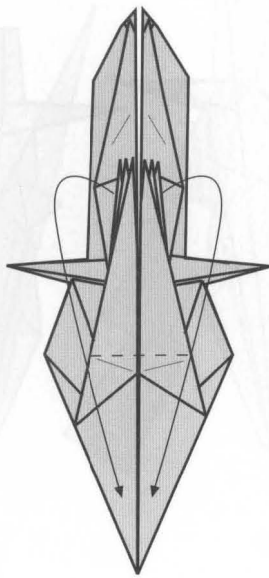

159

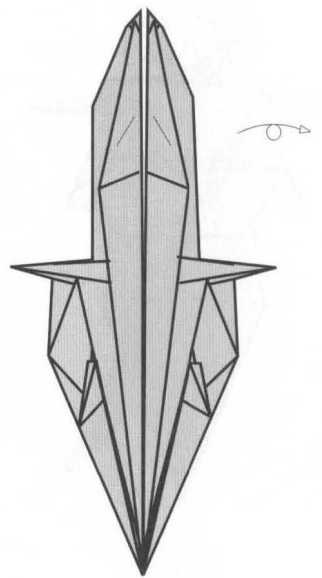

160

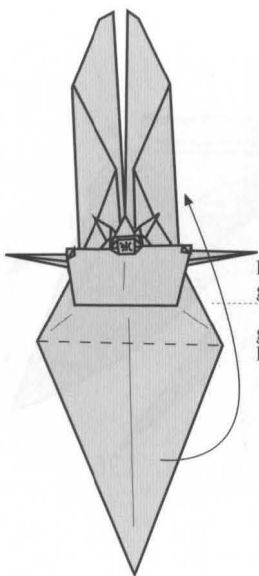

161

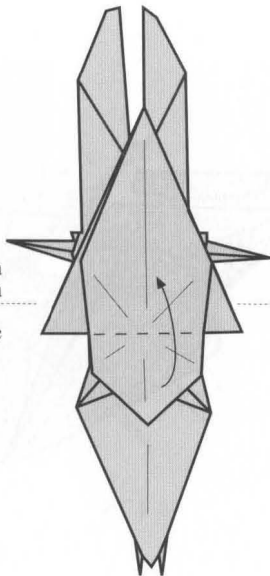

162

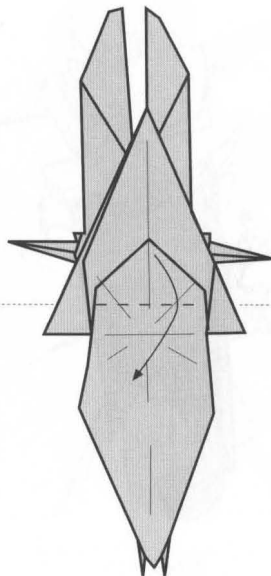

163

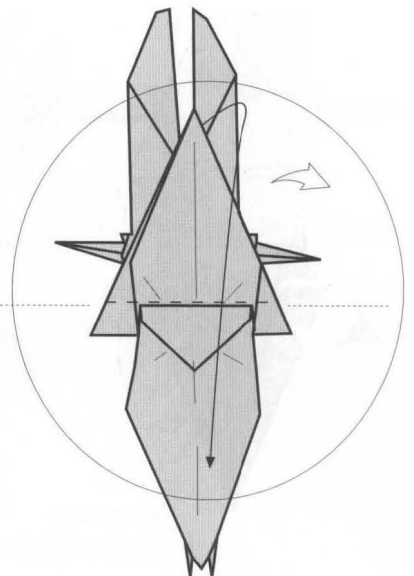

164

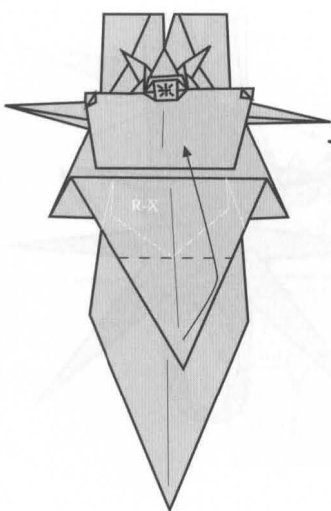

165

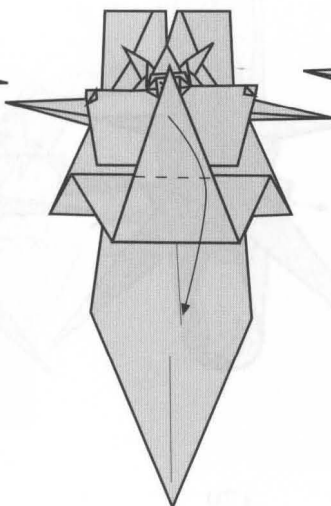

166

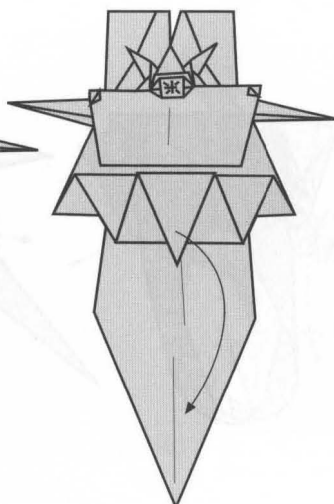

167

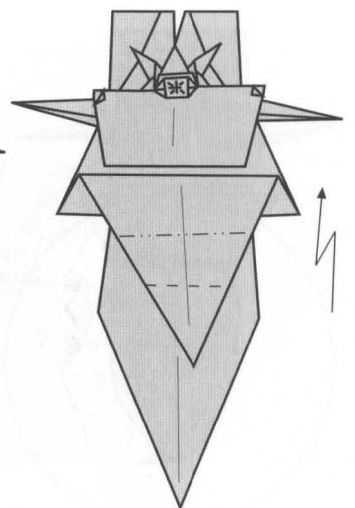

168

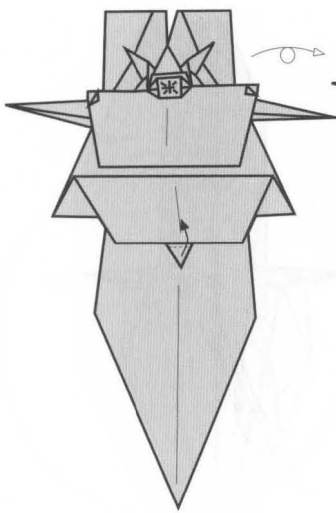

169

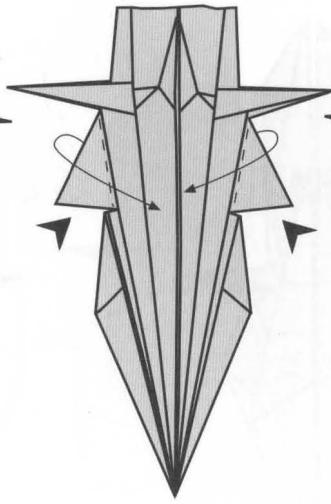

170

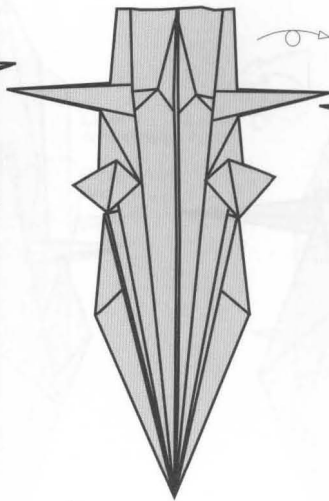

171

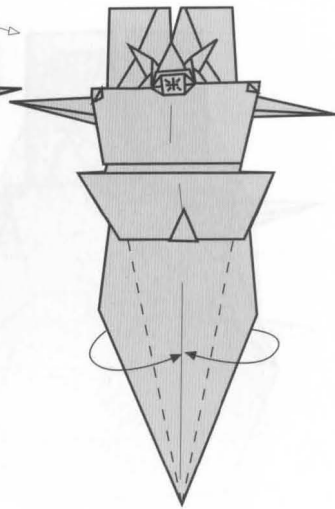

172

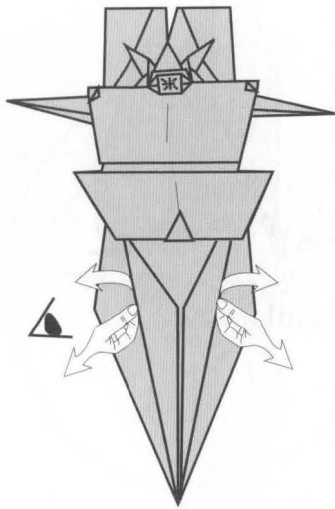

173

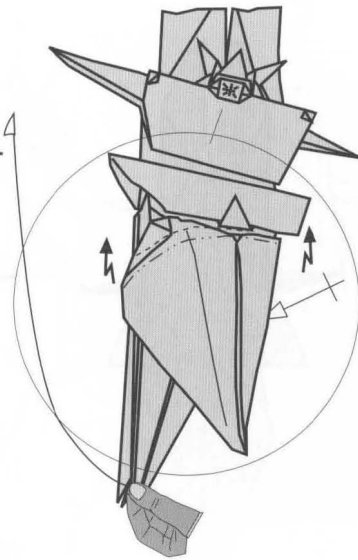

174

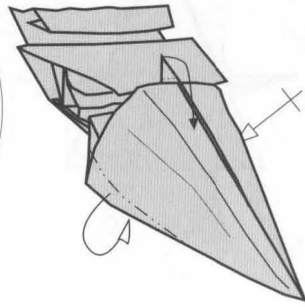

175

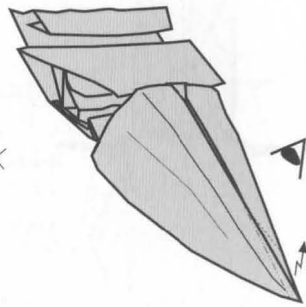

176

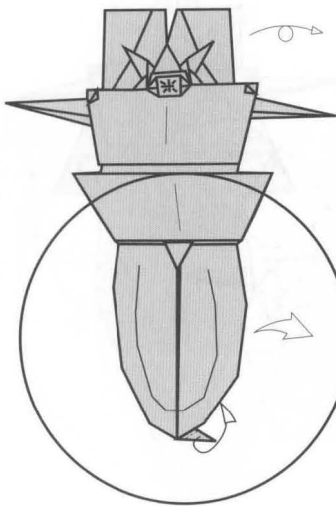

177

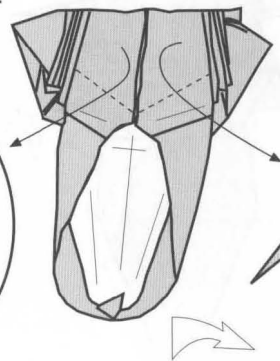

178

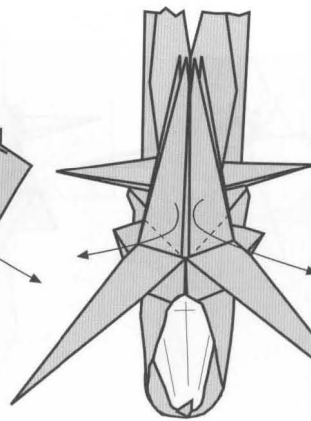

179

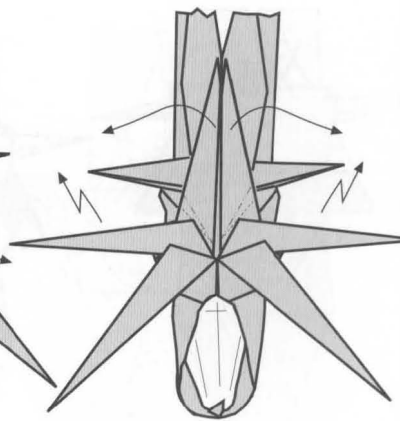

180

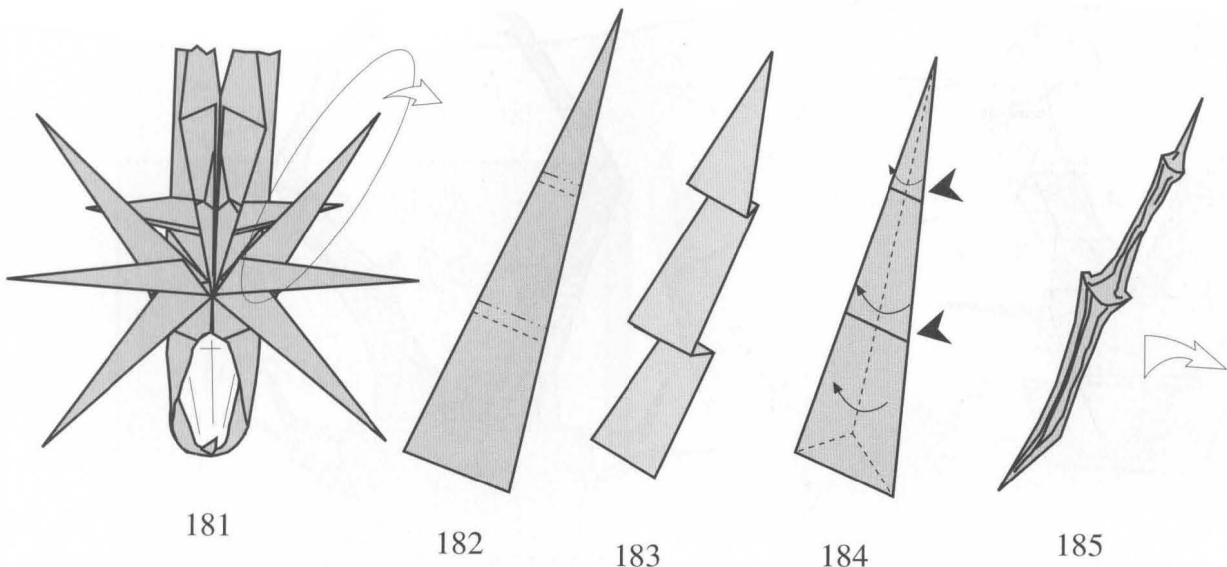

181

182

183

184

185

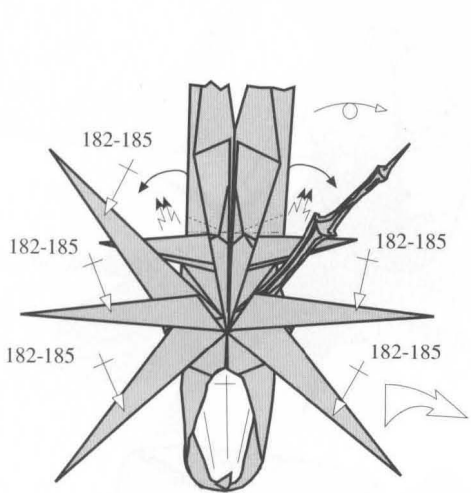

186

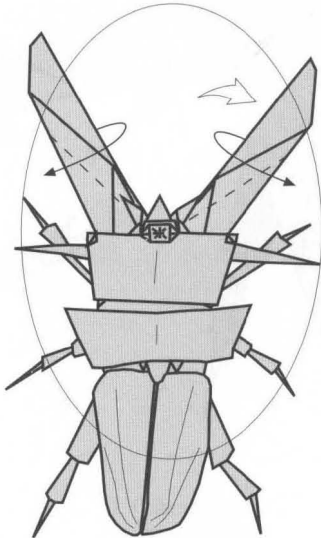

187

No dibujo las patas hasta el final.

The legs will be omitted until the end.

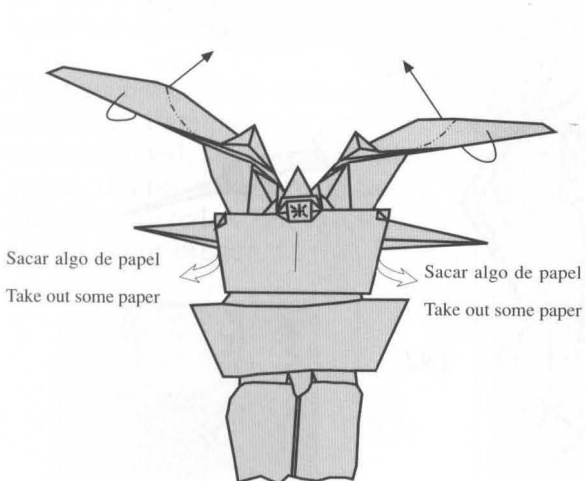

188

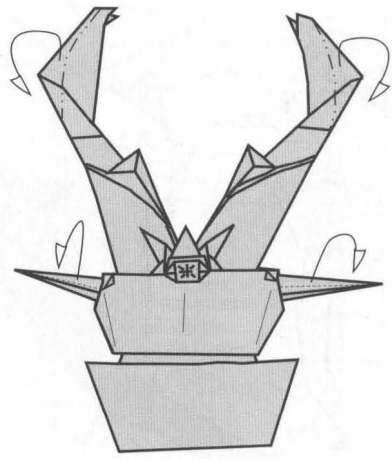

189

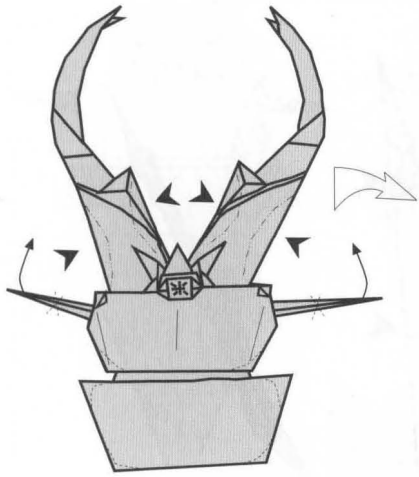

190

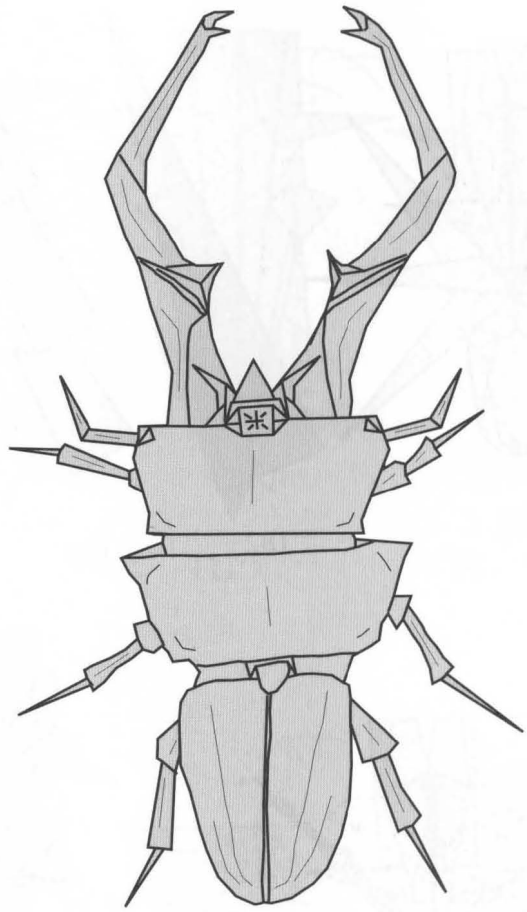

191

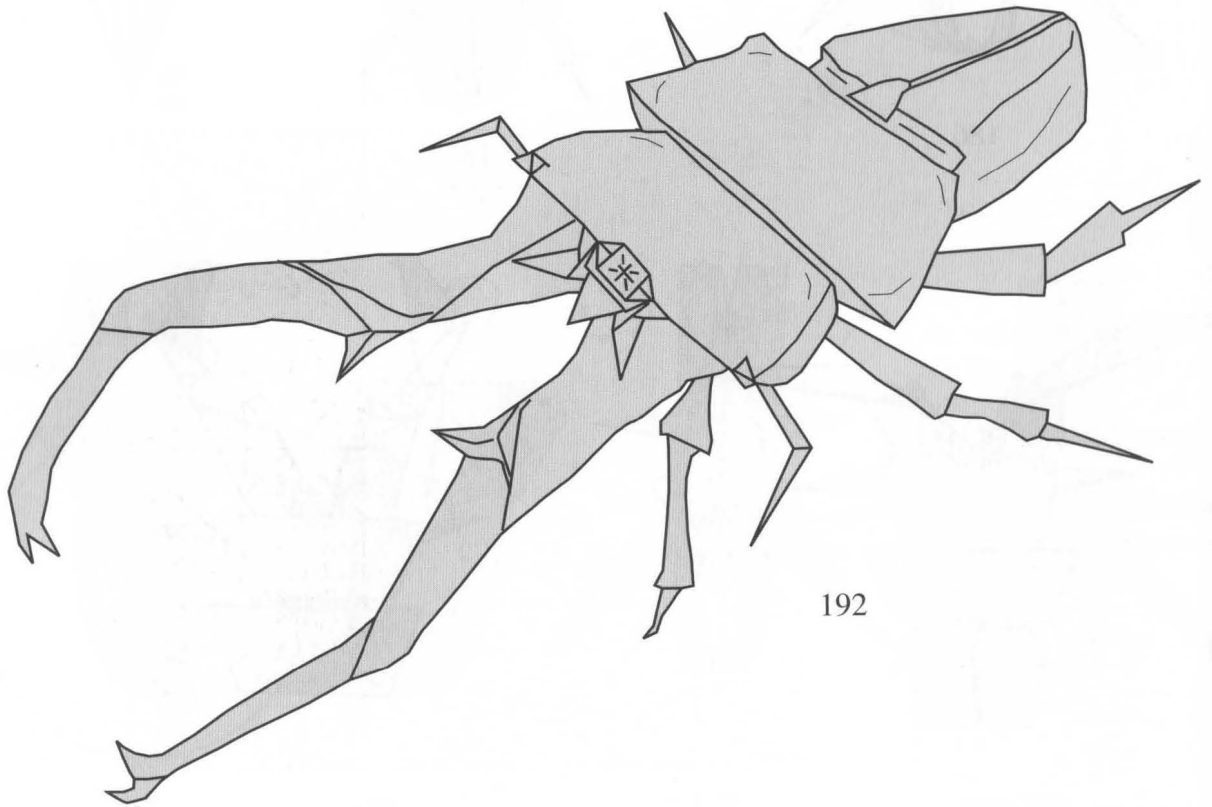

192

Ciervo volante

Lucanus cervus

© M. Sirgo - 2005

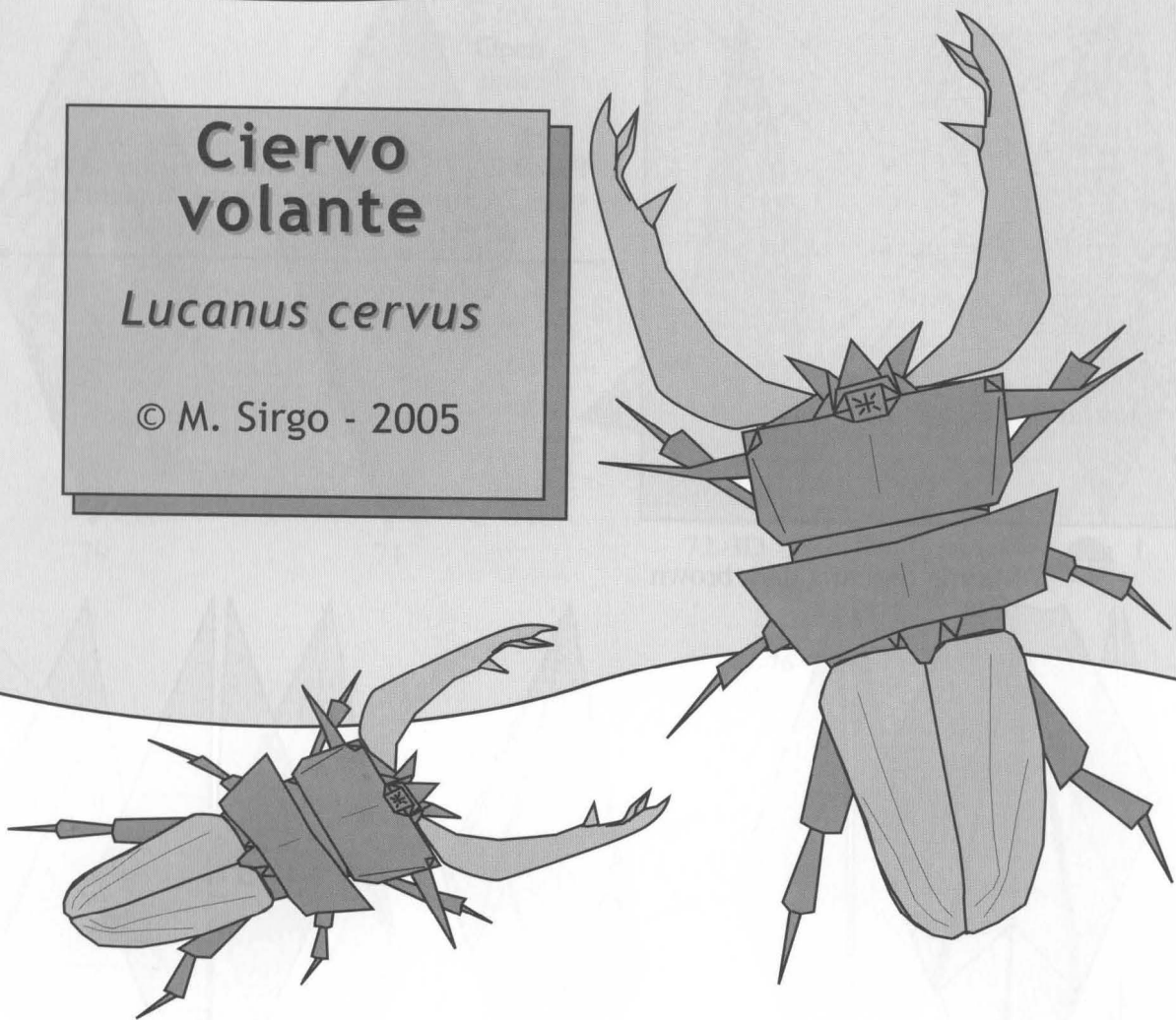

Cabeza, palpos
Head, palpuses

Mandíbula
Jaw

El papel debe ser marrón oscuro y negro. Se recomienda papel fino, menor de 40 gramos, doble seda, banano, lokta, metalizado o sandwich de 35x35 cm o mayor.

The paper should be brown dark and black. Fine paper is recommended, smaller than 40 grams, double silk, banana tree, lokta, metalized or sandwich of 35x35 cm or bigger.

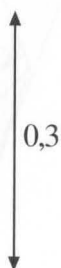
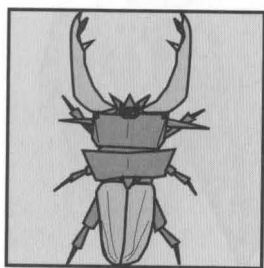
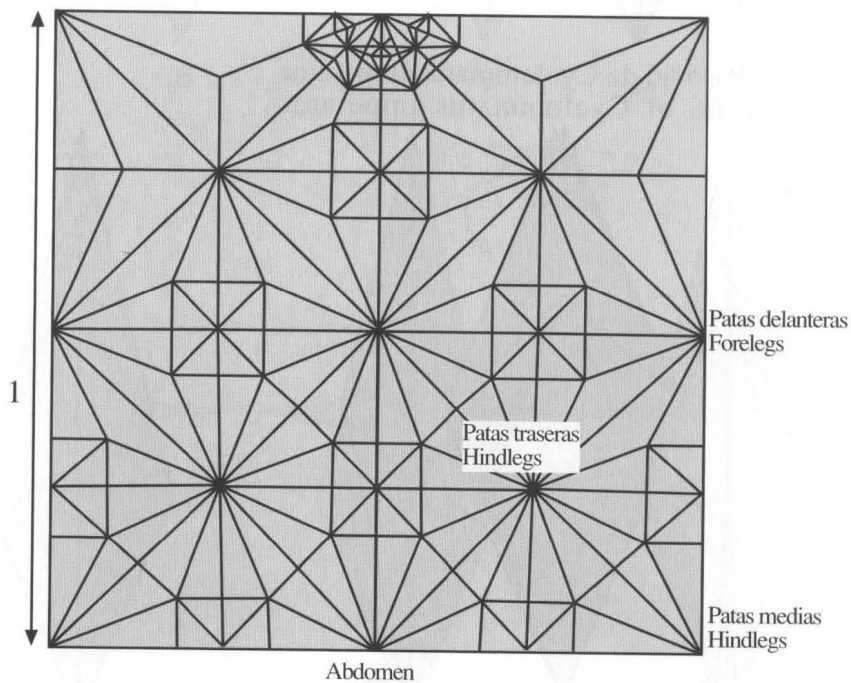

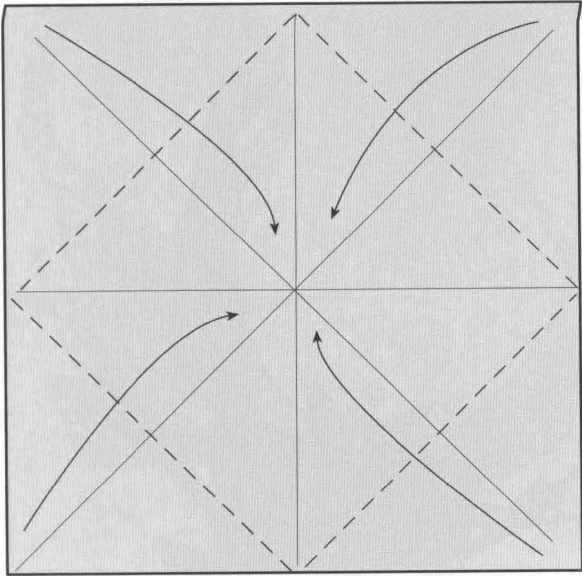

Pasos 2 a 65 de Cyclommatus Imperator
 steps 2 until 65 of cyclommatus imperator



1 ● Negro, black
 ○ Marrón oscuro, dark brown

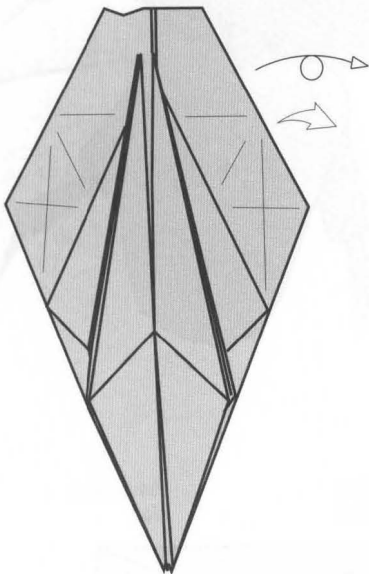

66. Paso 66 de Cyclommatus Imperator
 step 66 of Cyclommatus Imperator

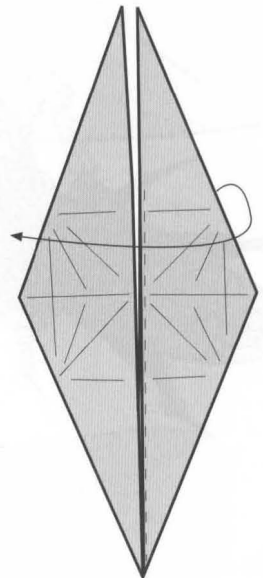

67

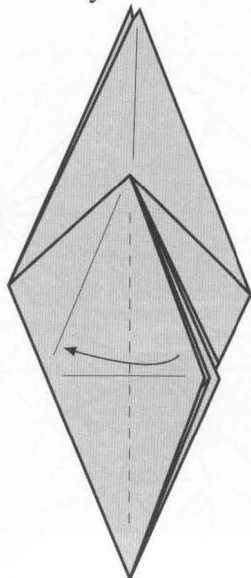

68

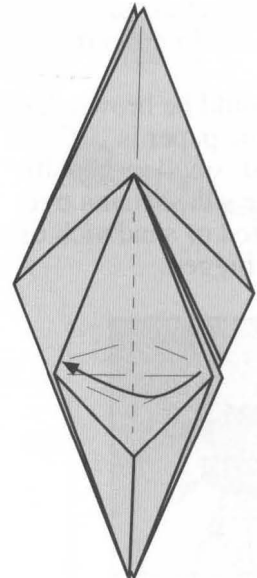

69

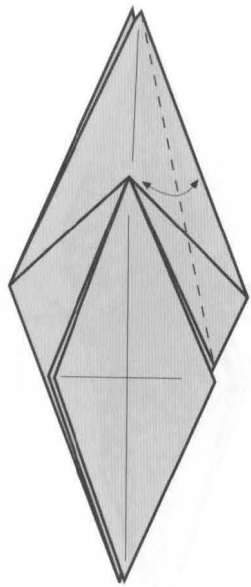

70

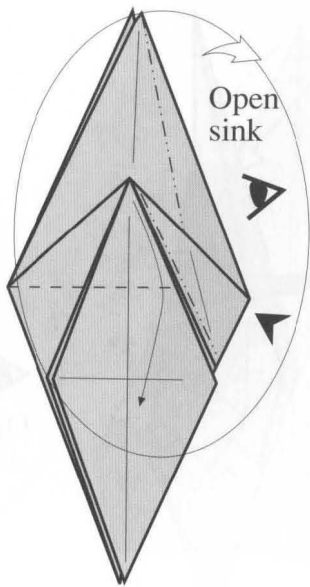

71

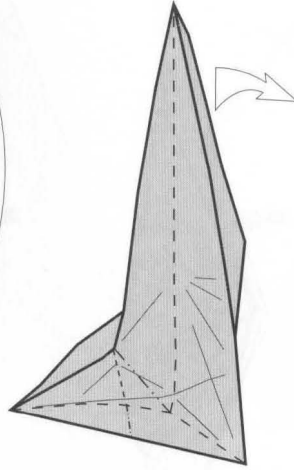

72-3D

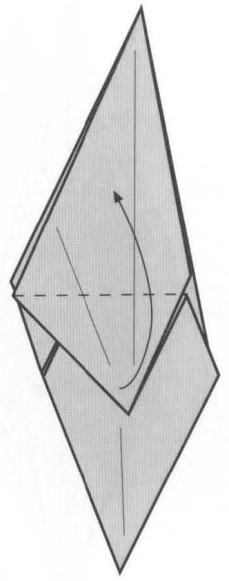

73

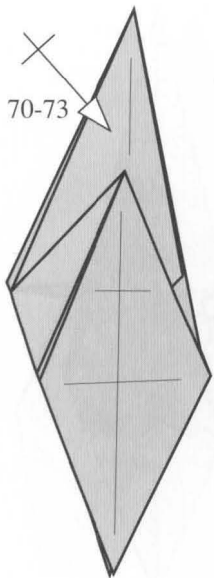

74

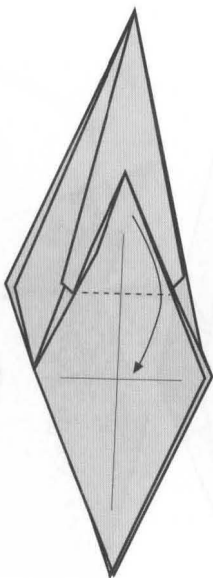

75

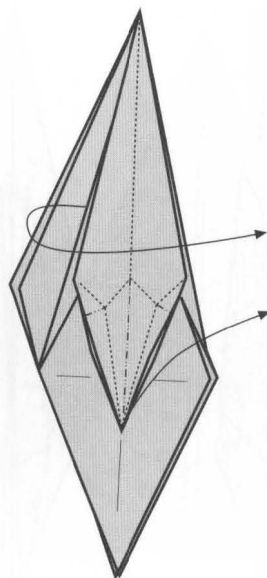

76

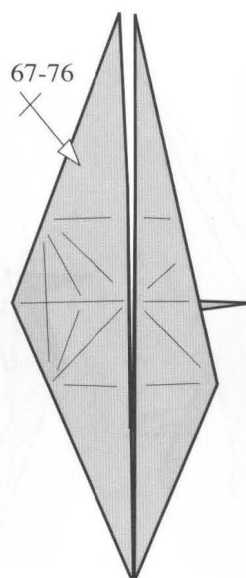

77

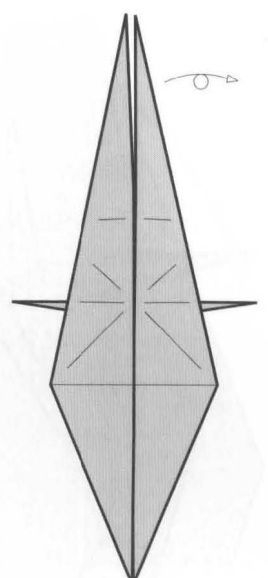

78

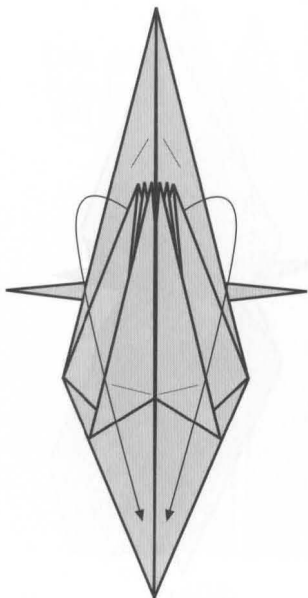

79

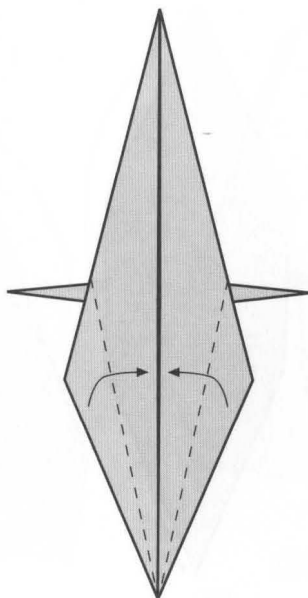

80

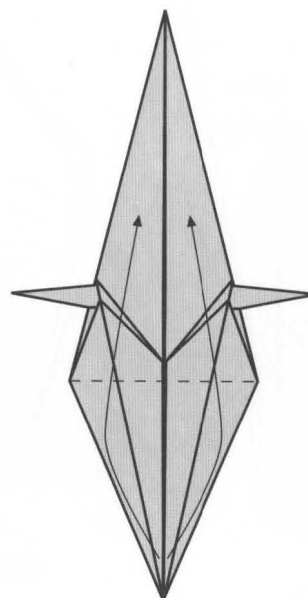

81

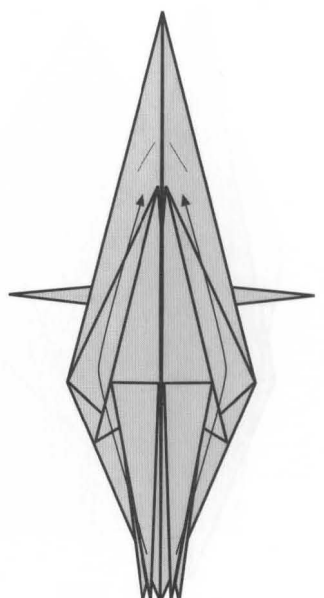

82

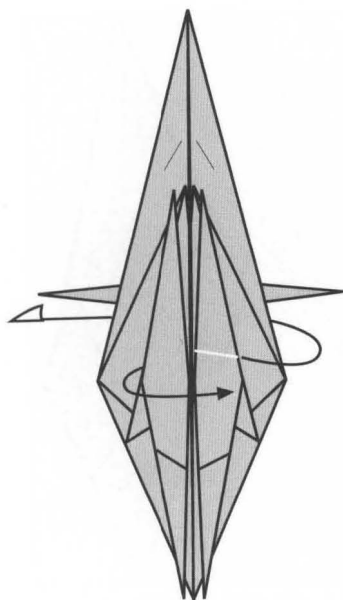

83

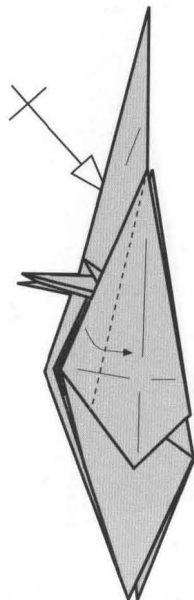

84

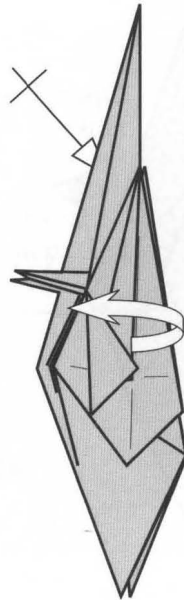

85

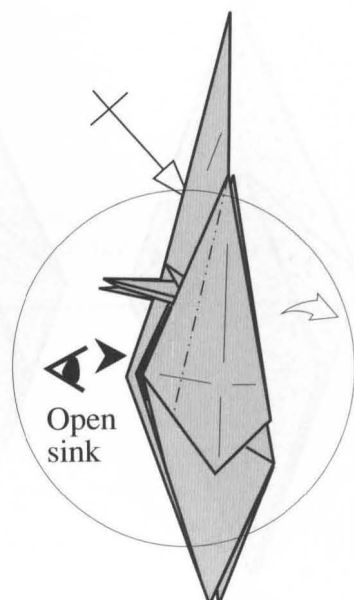

86

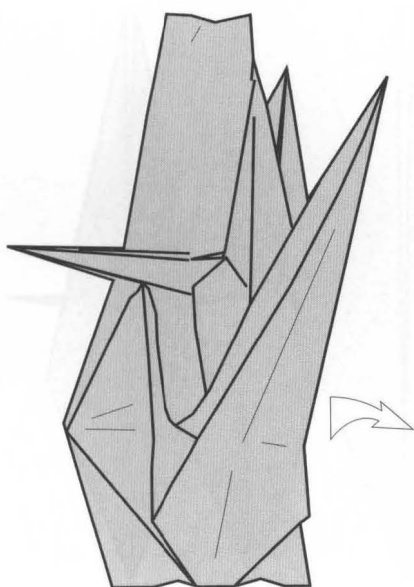

87-3D

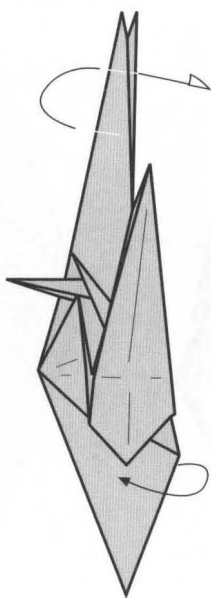

88

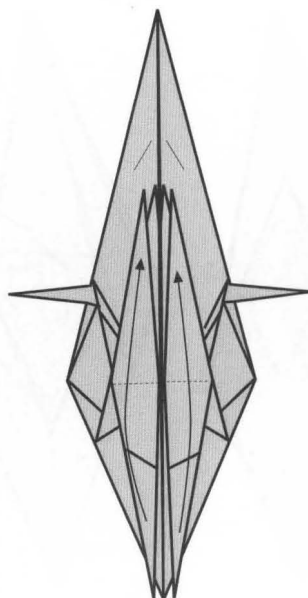

89

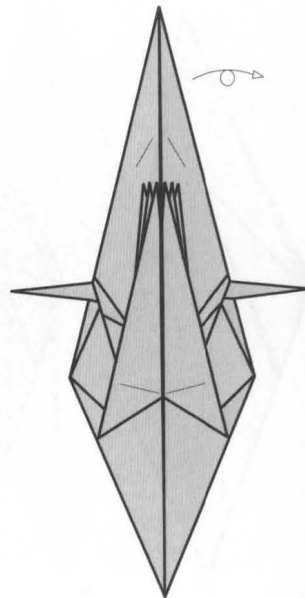

90

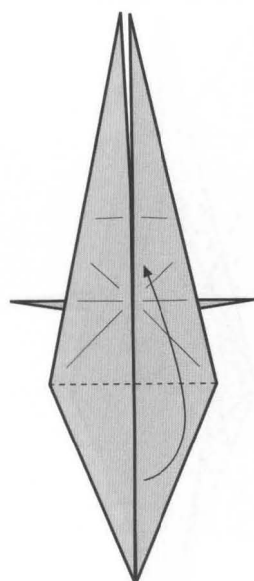

91

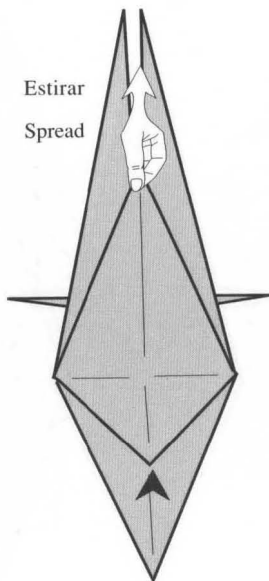

92

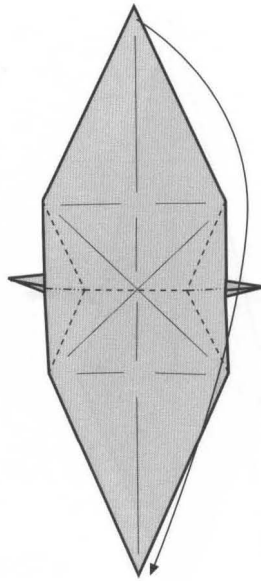

93

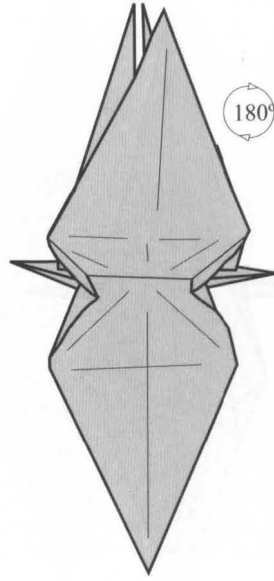

94-3D

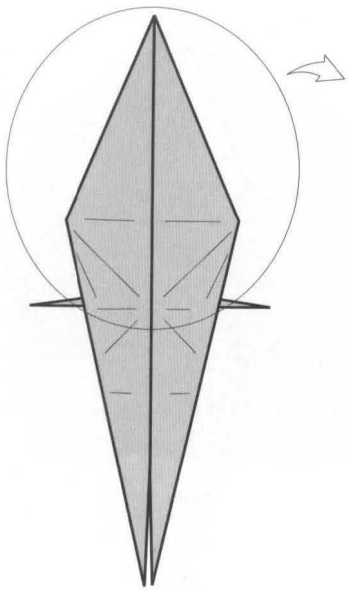

95

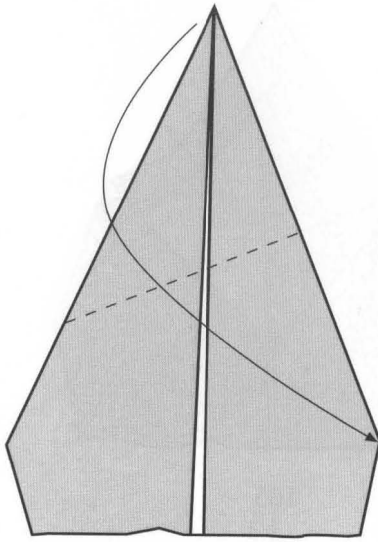

96

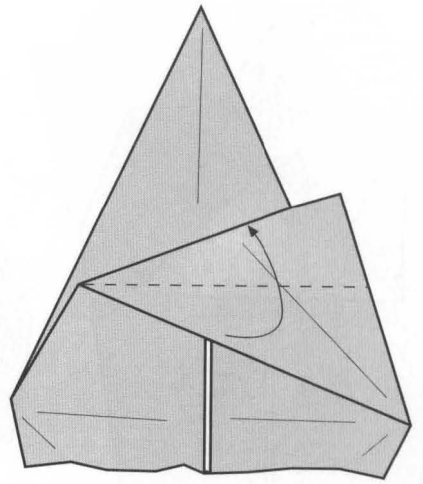

97

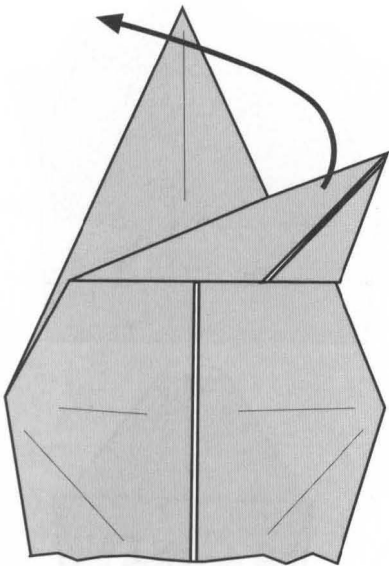

98

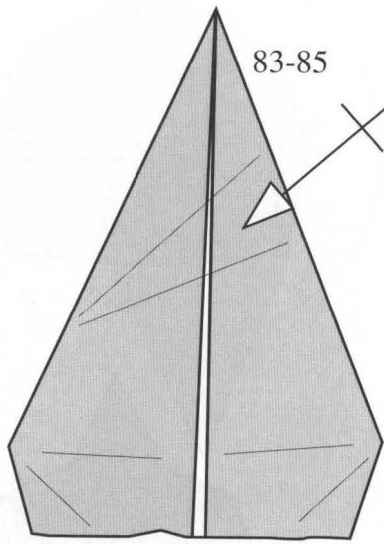

99

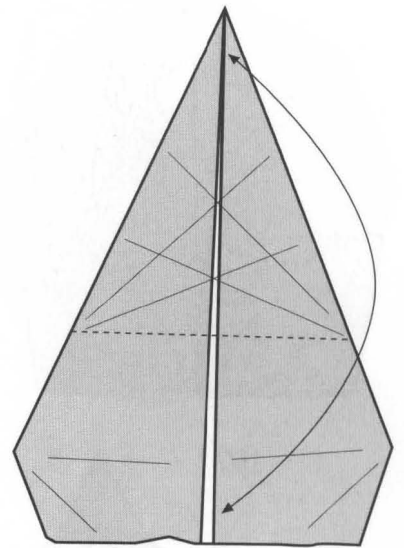

100

Dos capas
Two layers

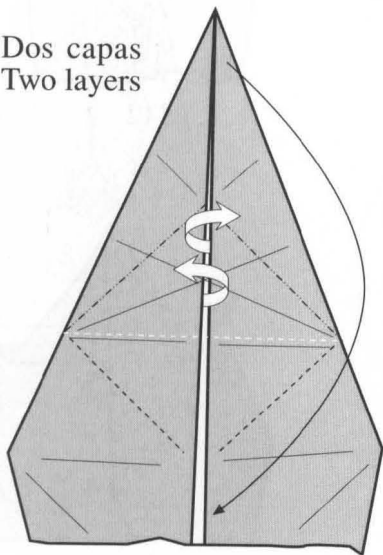

101

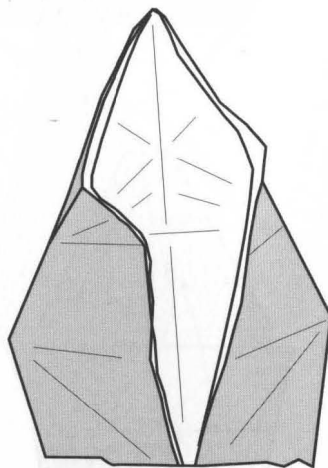

102-3D

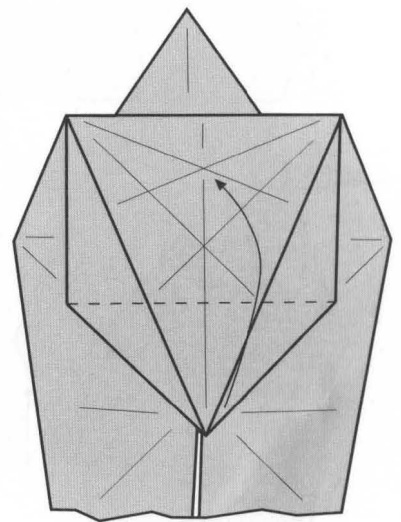

103

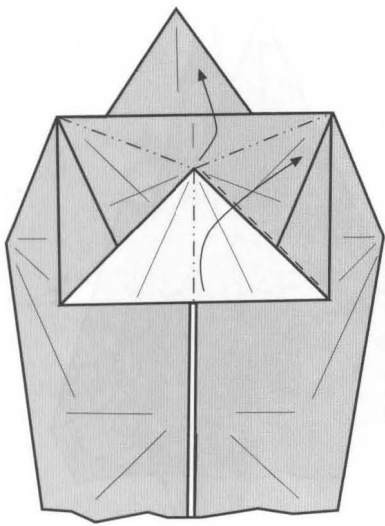

104

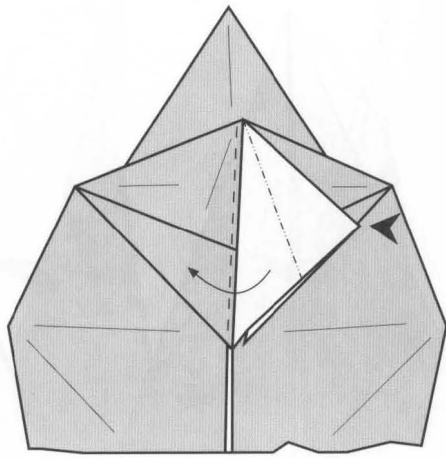

105

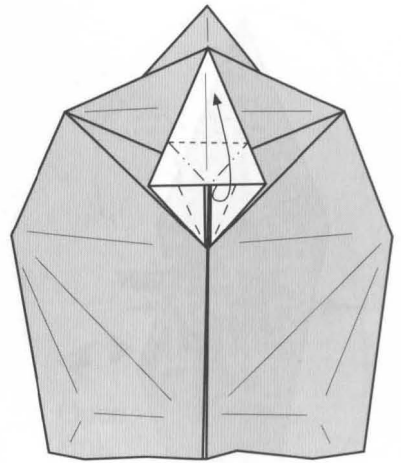

106

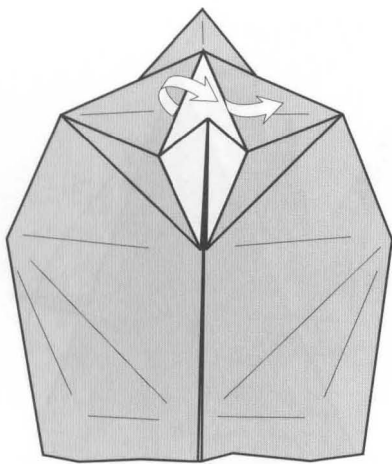

107

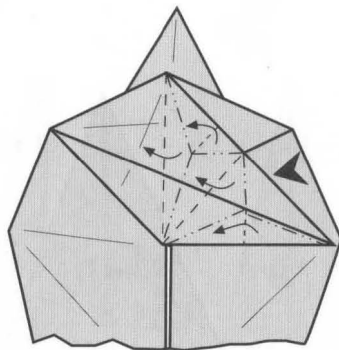

108

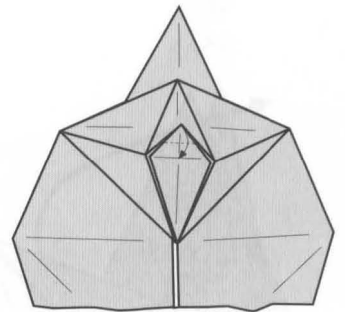

109

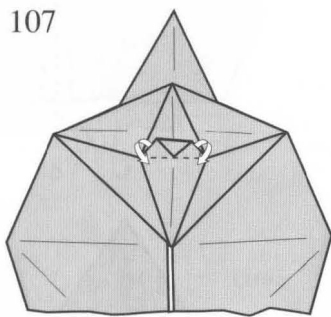

110

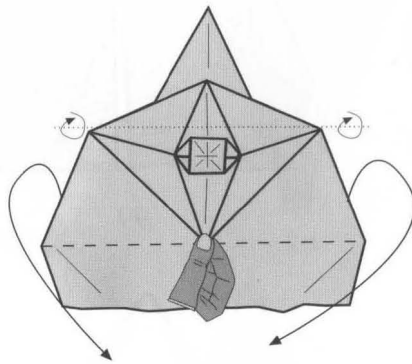

111

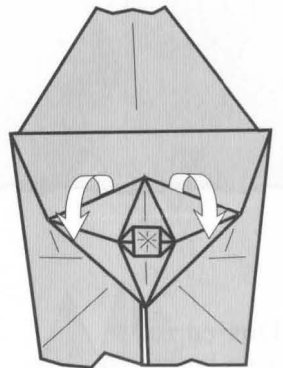

112

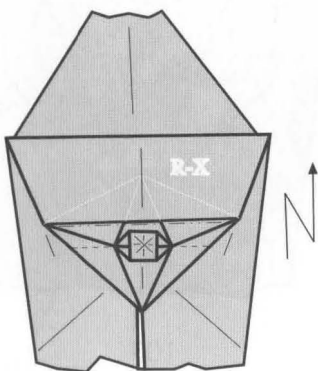

113

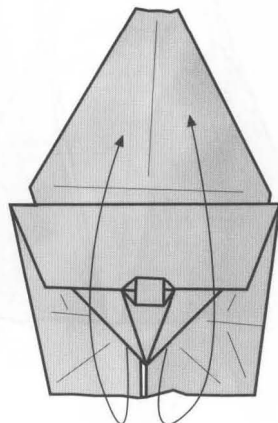

114

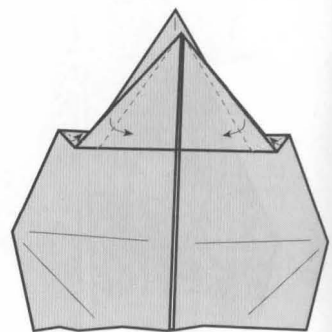

115

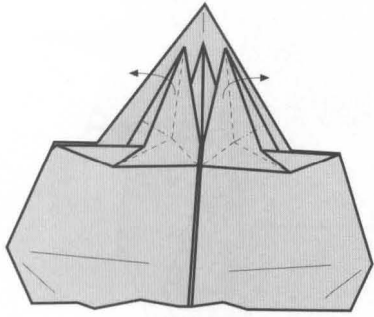

116

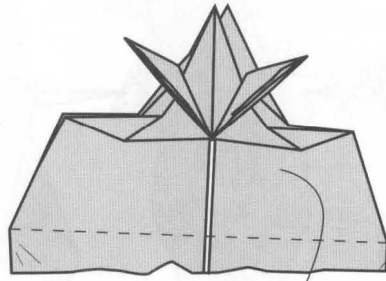

117

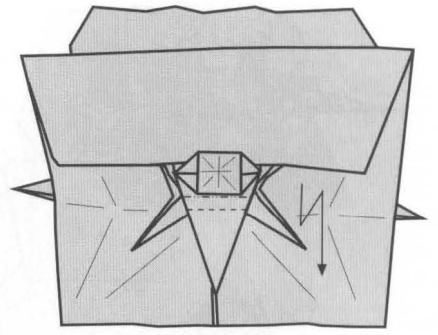

118

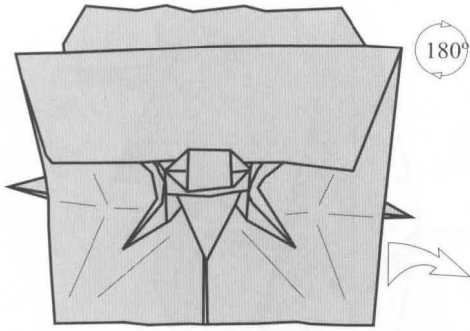

119

180°

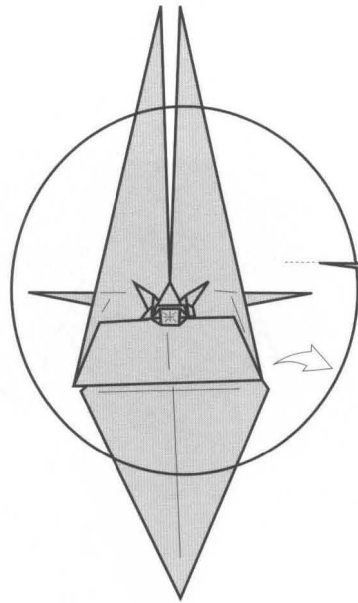

120

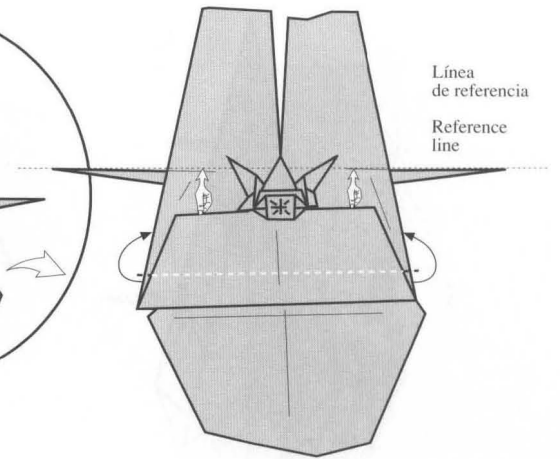

121

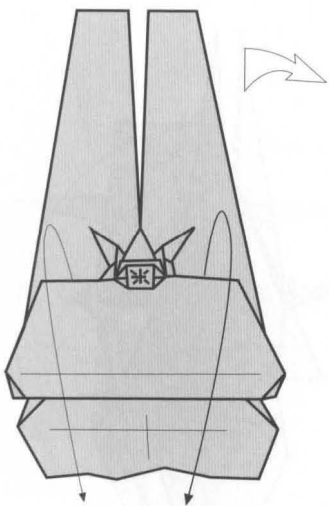

122

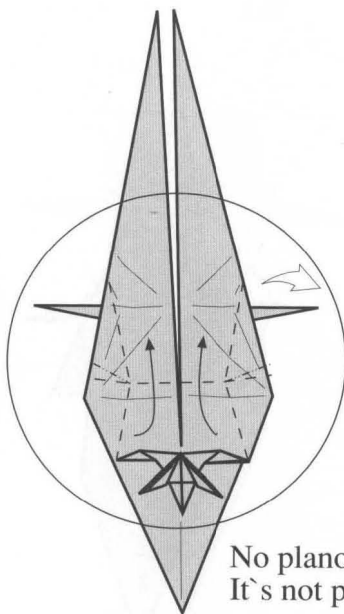

123

No plano
It's not plain

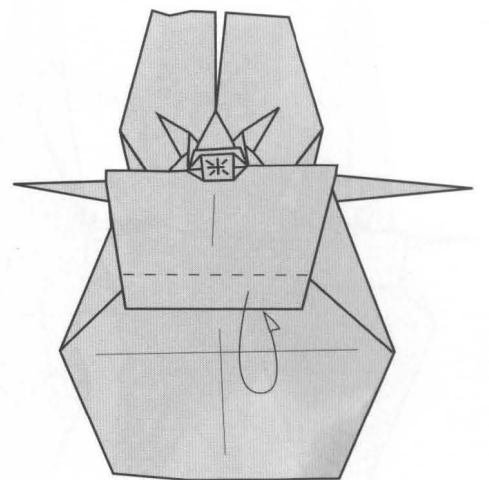

124

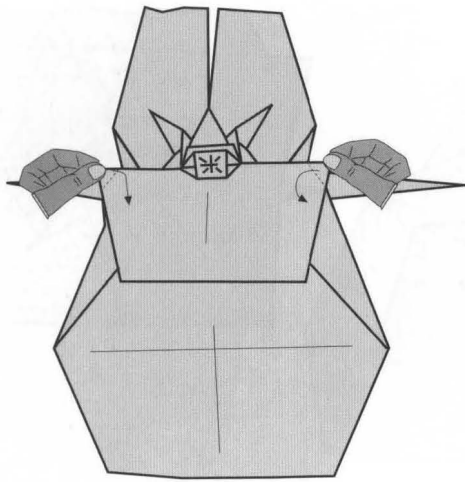

125

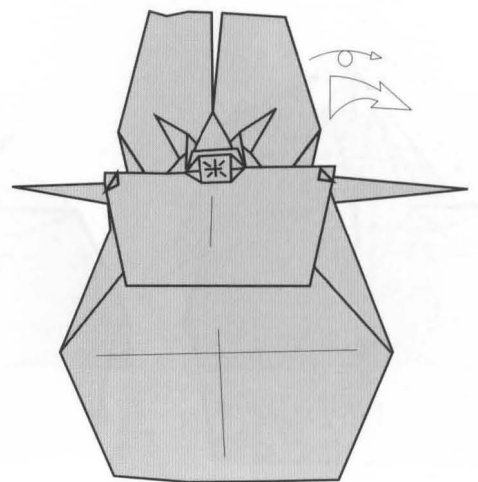

126

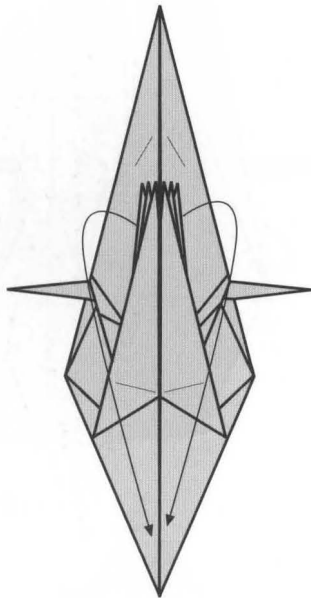

127

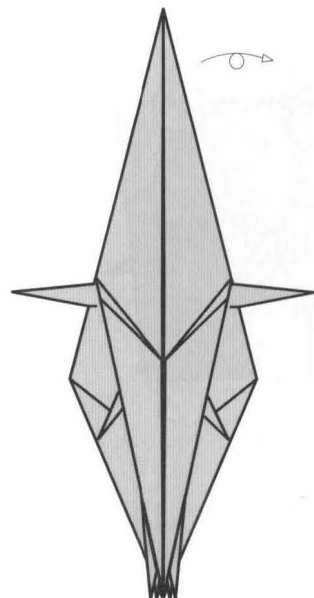

128

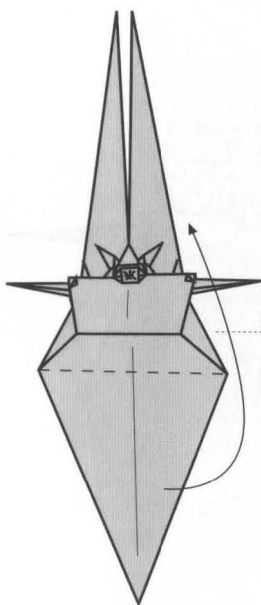

129

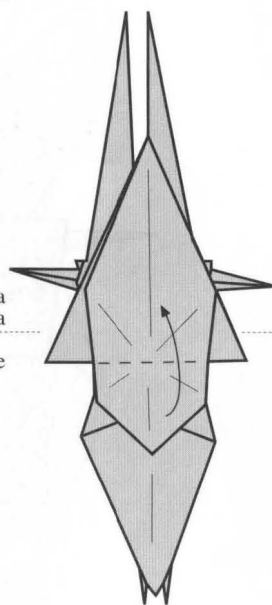

130

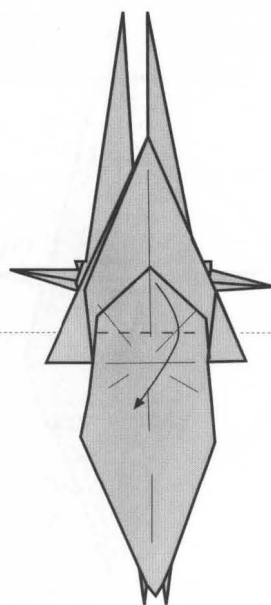

131

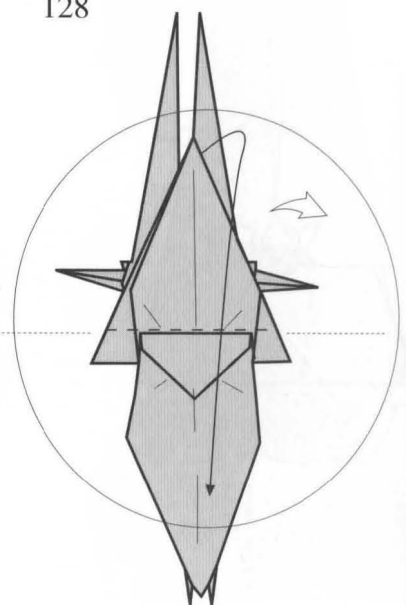

132

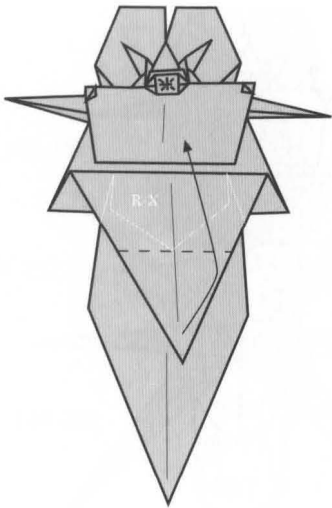

133

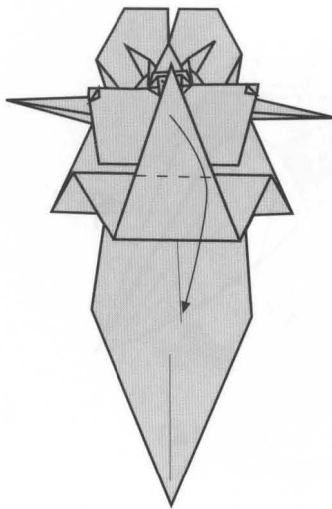

134

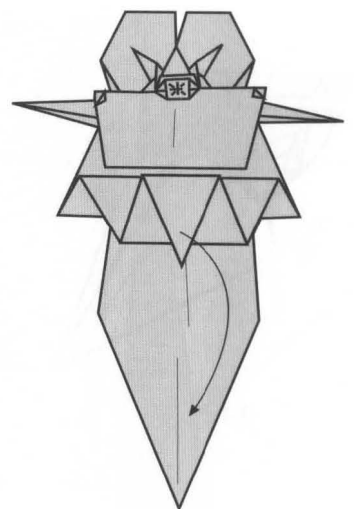

135

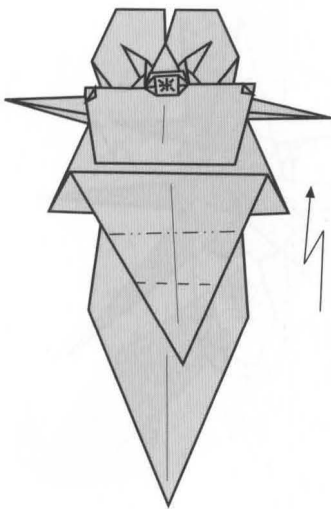

136

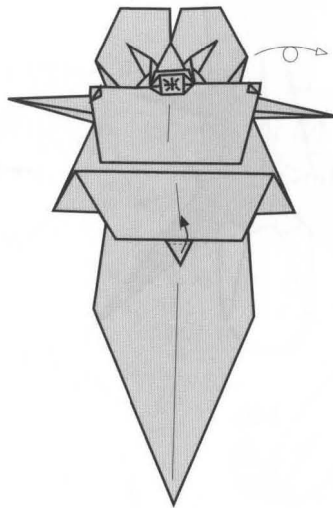

137

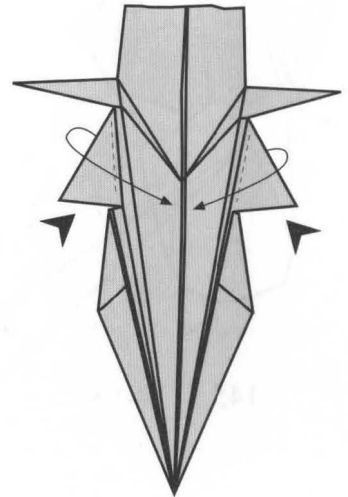

138

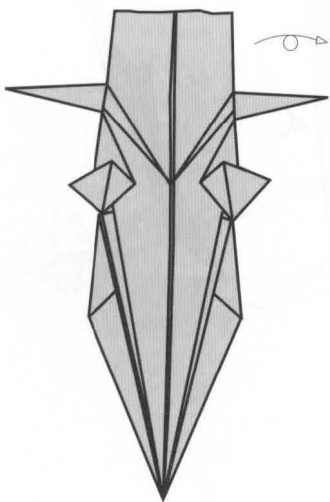

139

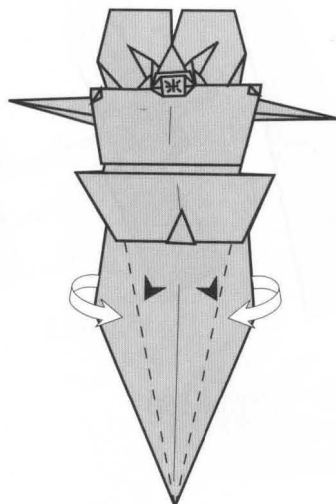

Cambio de color
Colour change

140

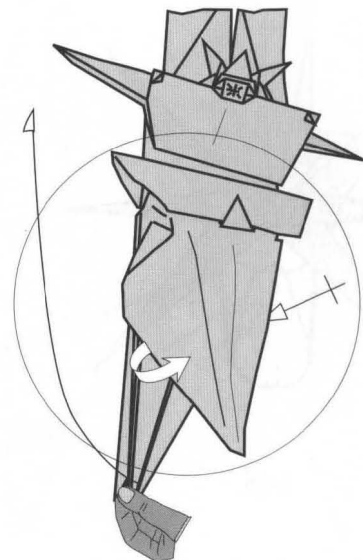

141-3D

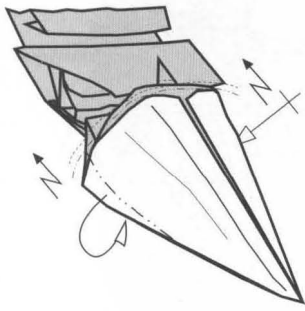

142

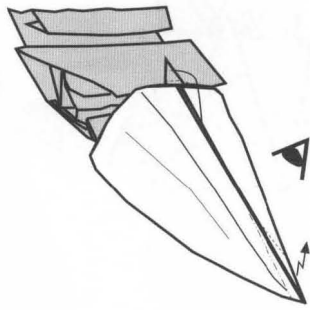

143

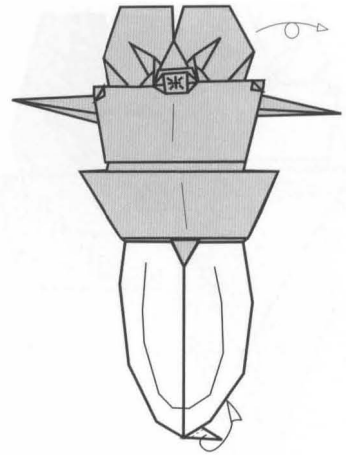

144

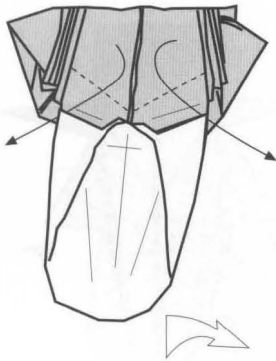

145

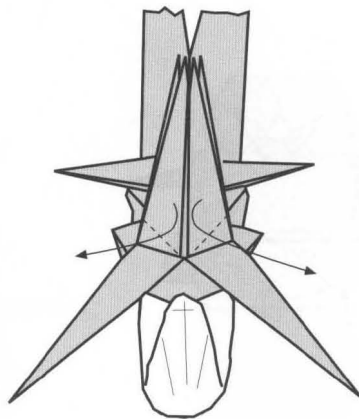

146

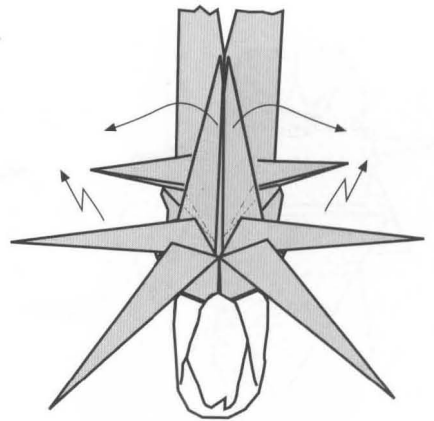

147

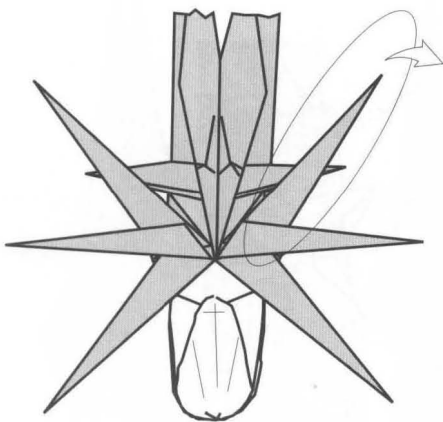

148

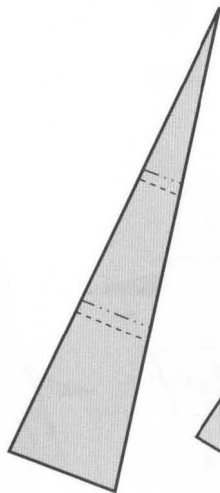

149

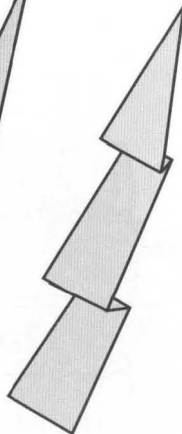

150

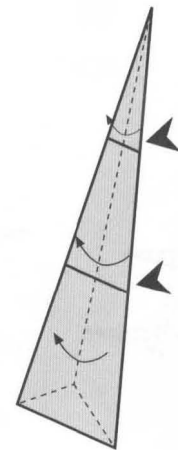

151

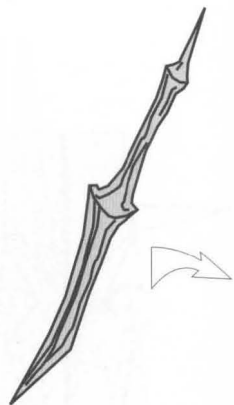

152

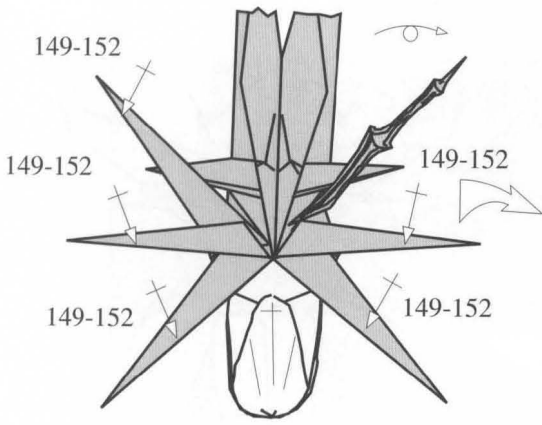

153

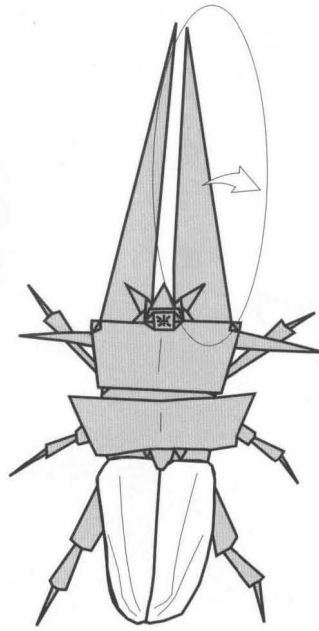

154

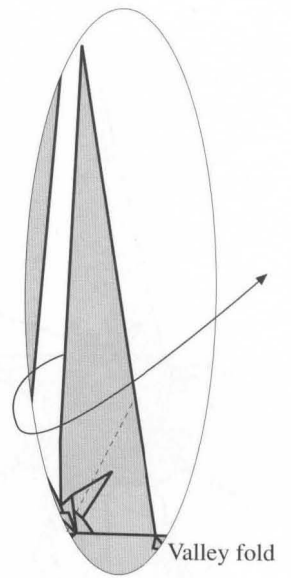

155

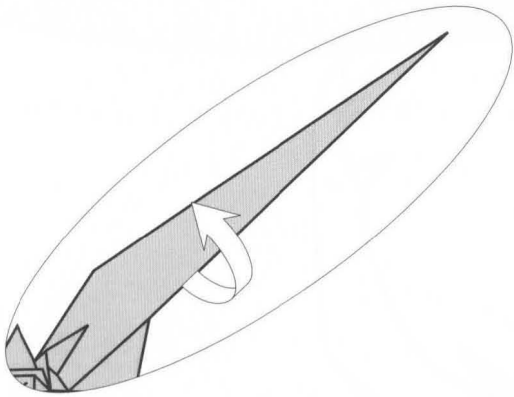

156

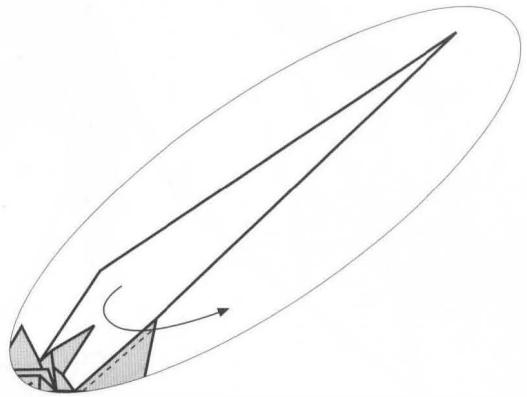

157

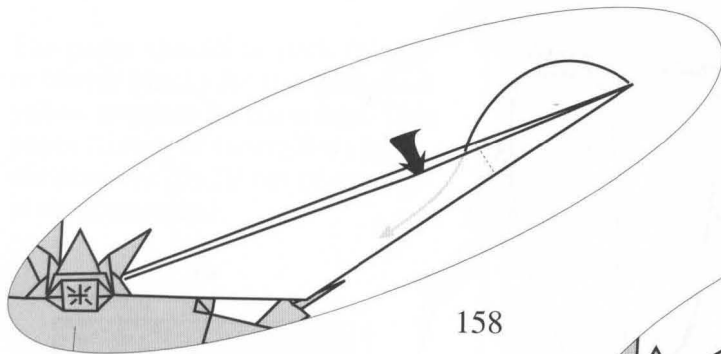

158

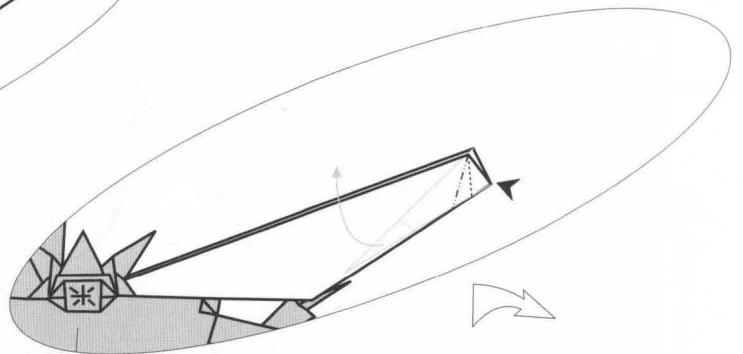

159

154-159

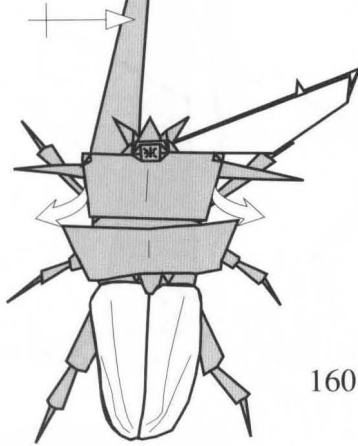

160

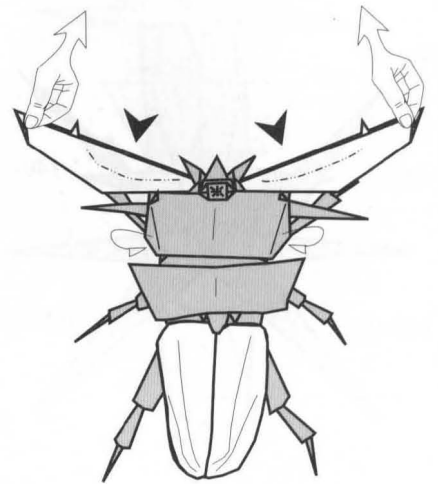

161

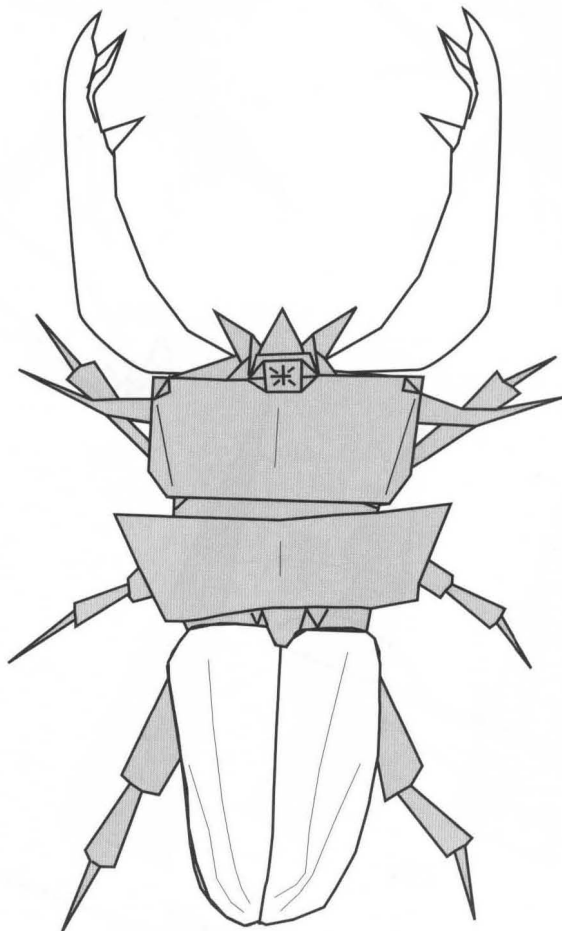

162



Cisne nadando

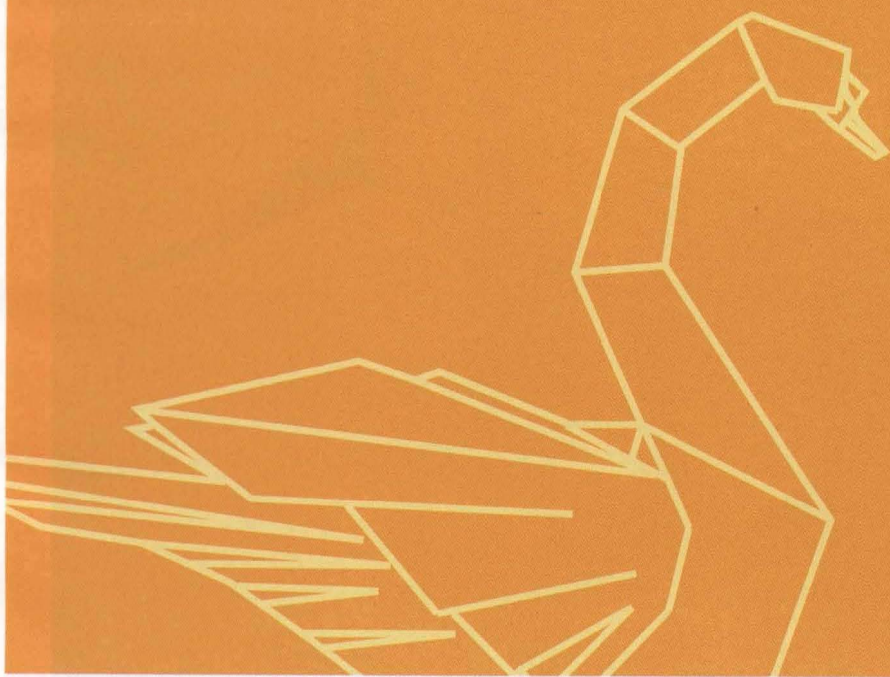

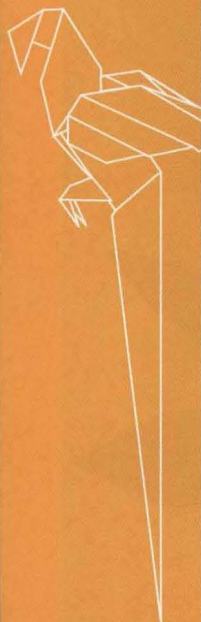

Dugón



Guacamayo



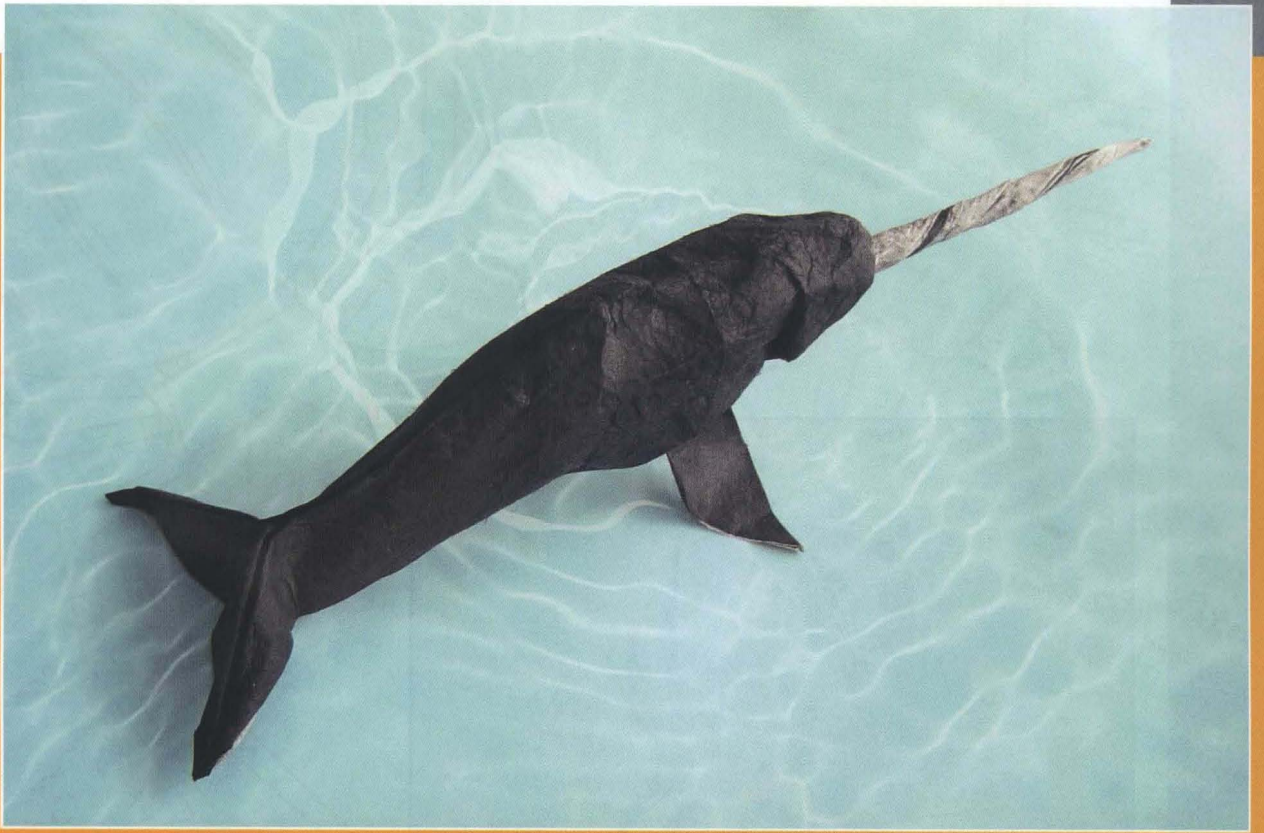

Narval

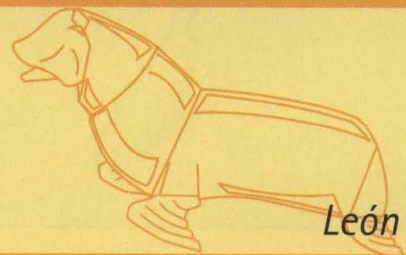
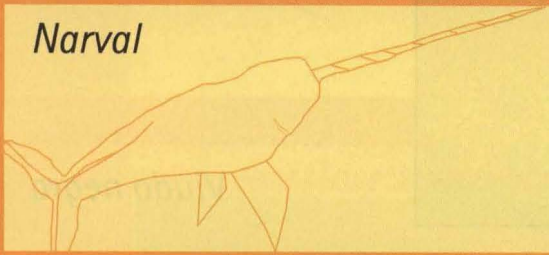

León marino



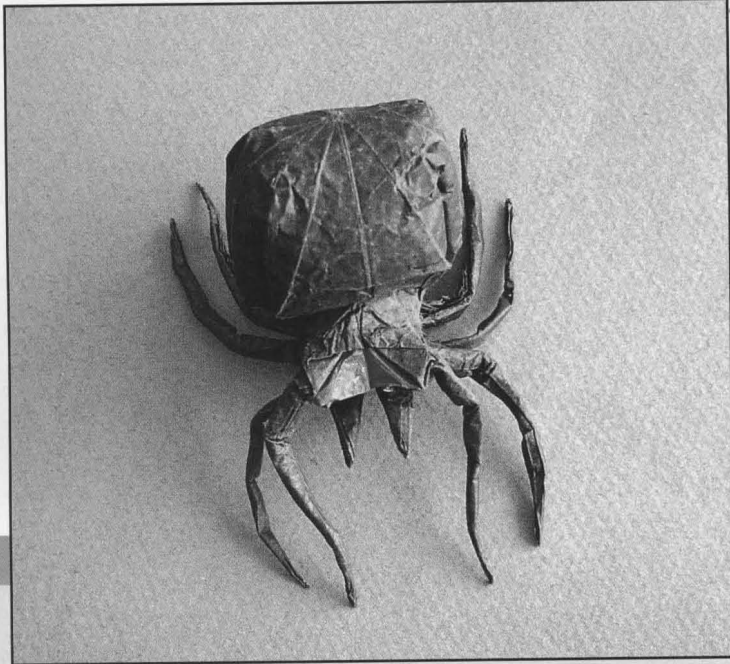

Viuda negra



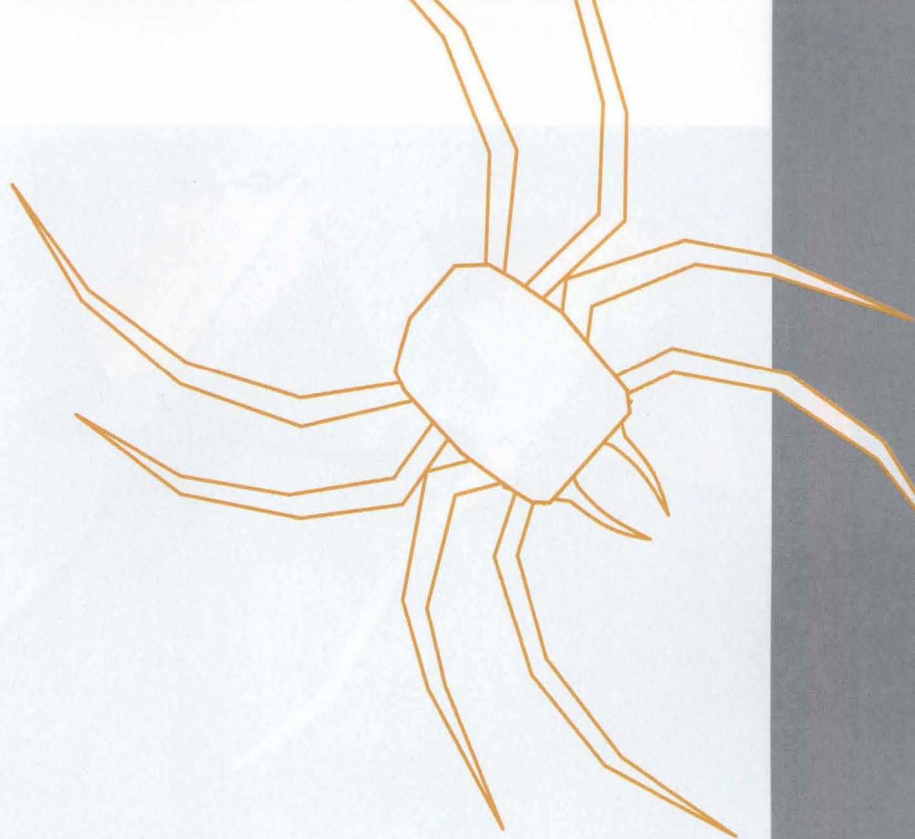

Falangio





Raya

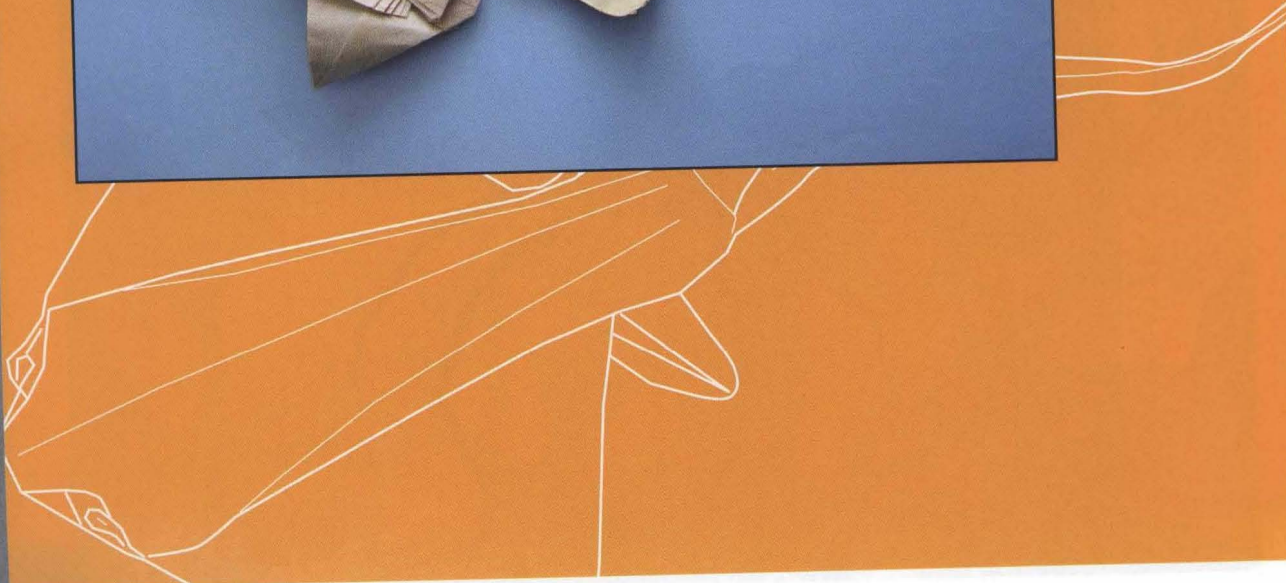
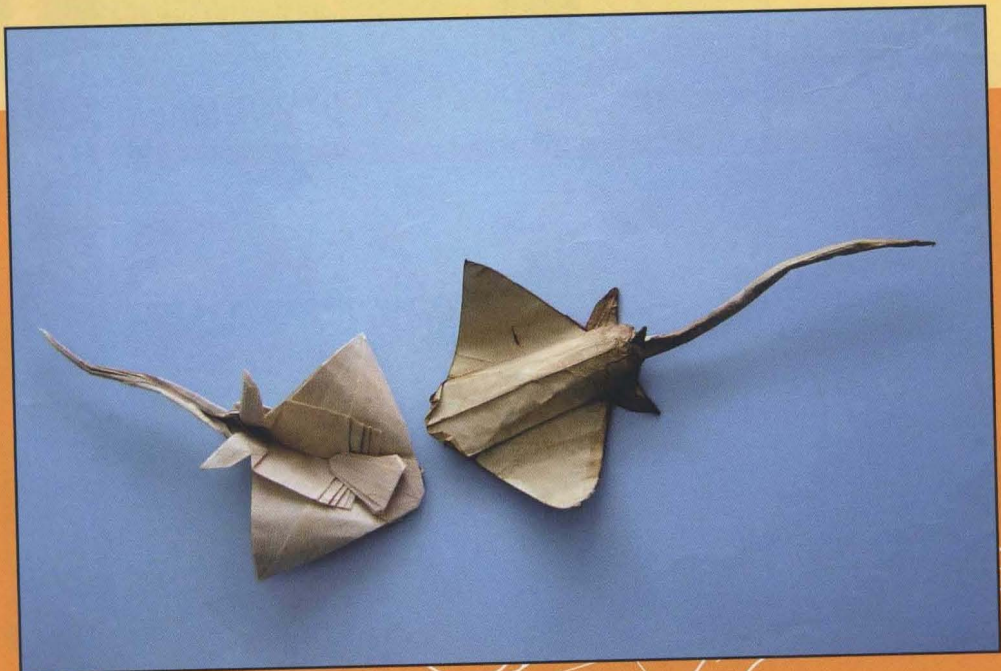



Cocodrilo del Nilo

Estrella

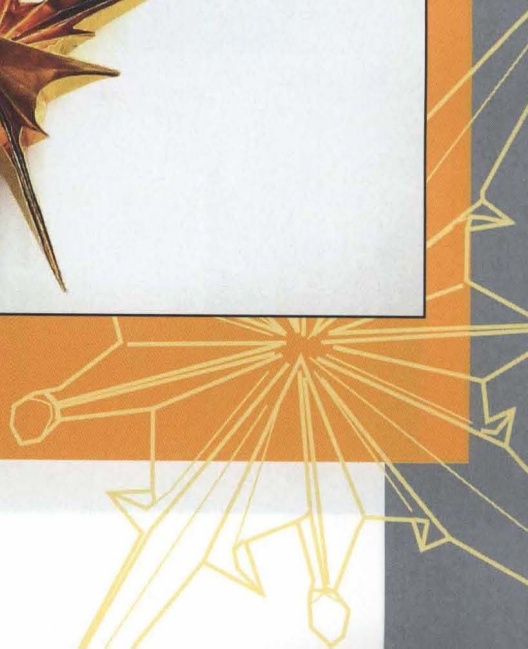

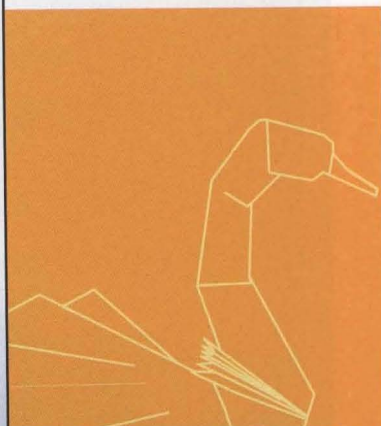

Cisne



Leptynia hispánica

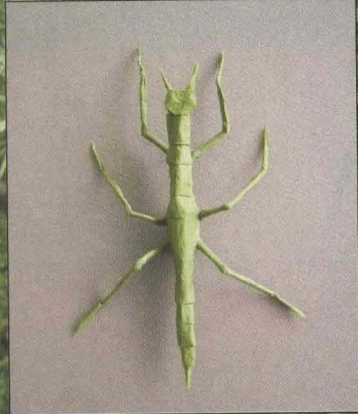

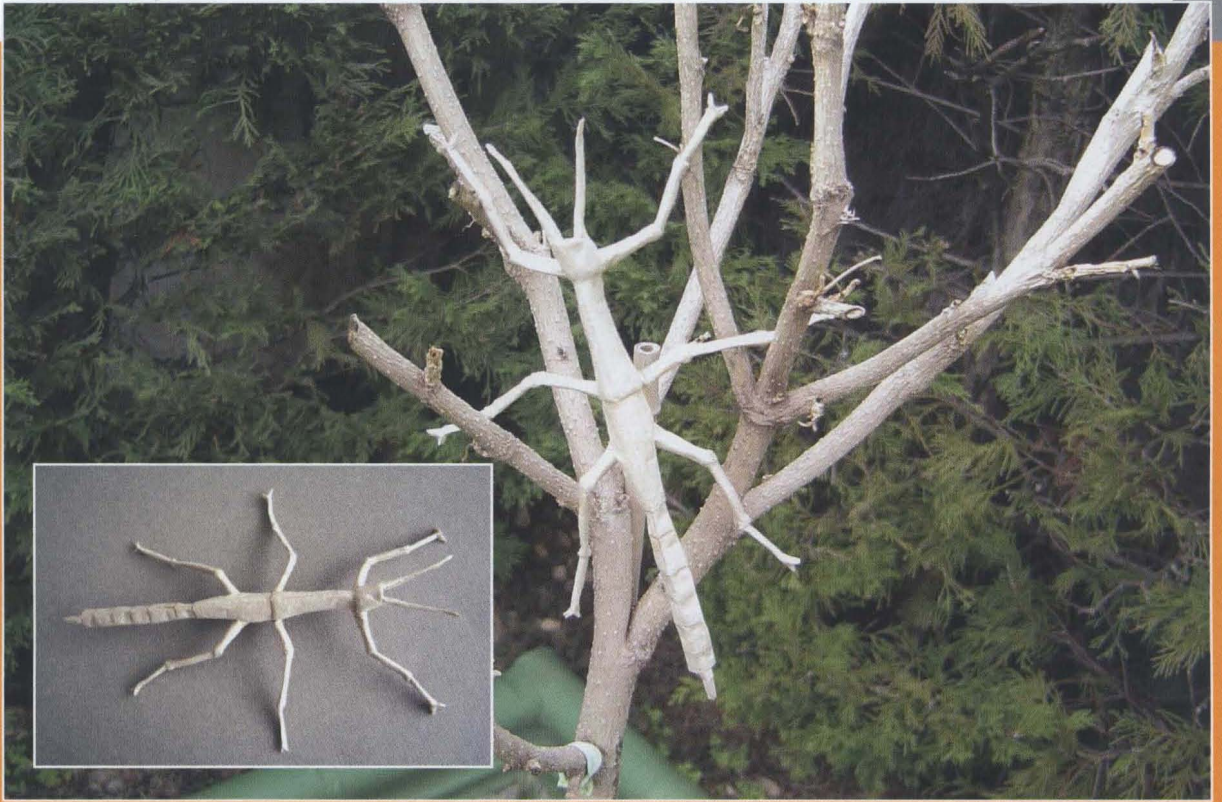

Mantis hoja

Pharnacia





Hormiga negra

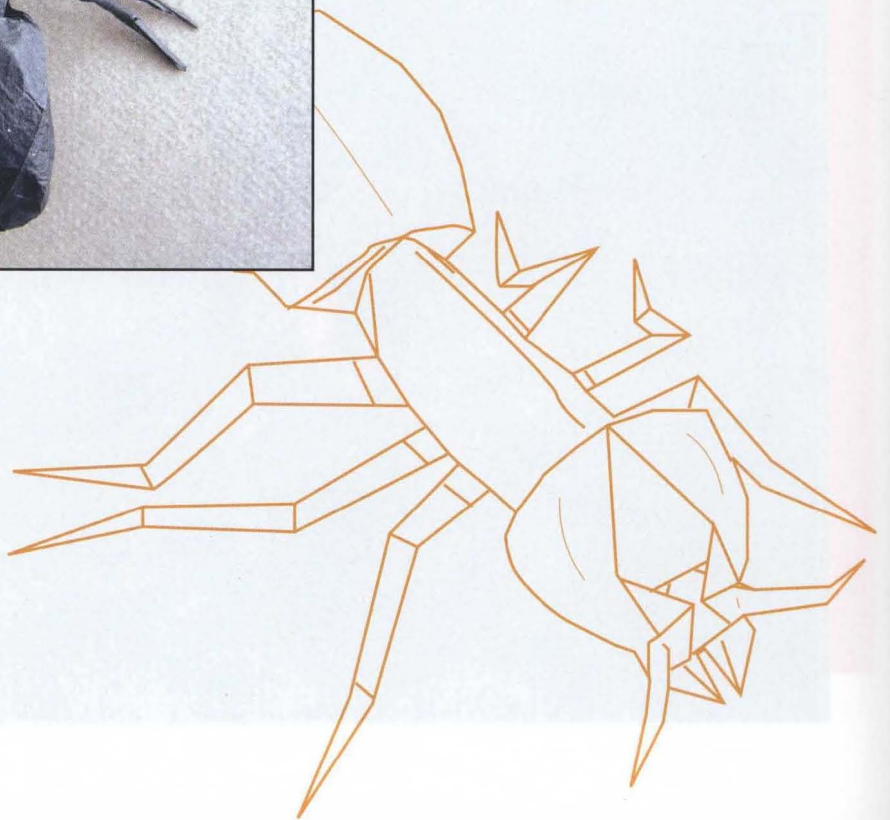
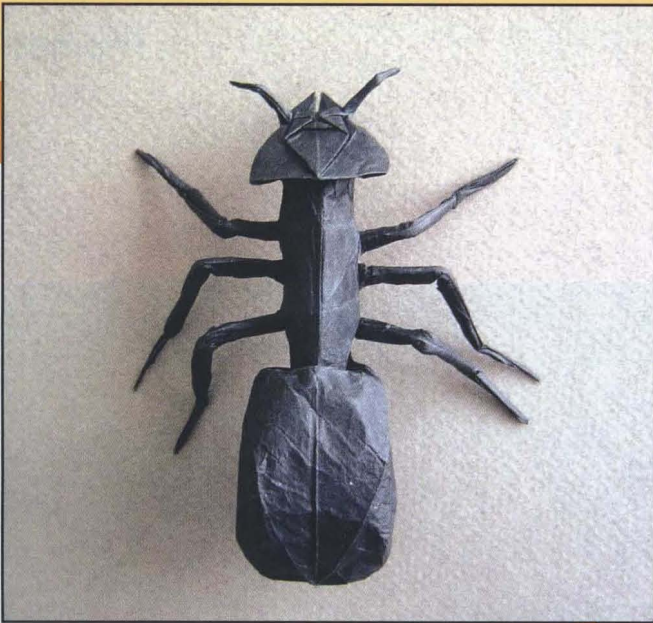



Pseudoscorpion

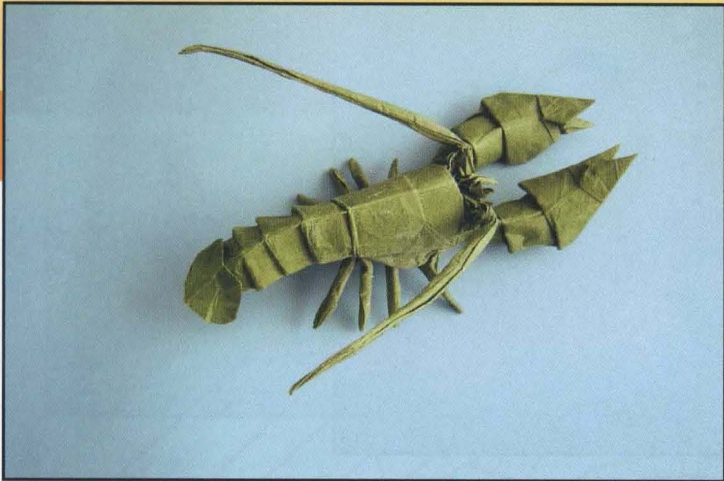

Cangrejo de río

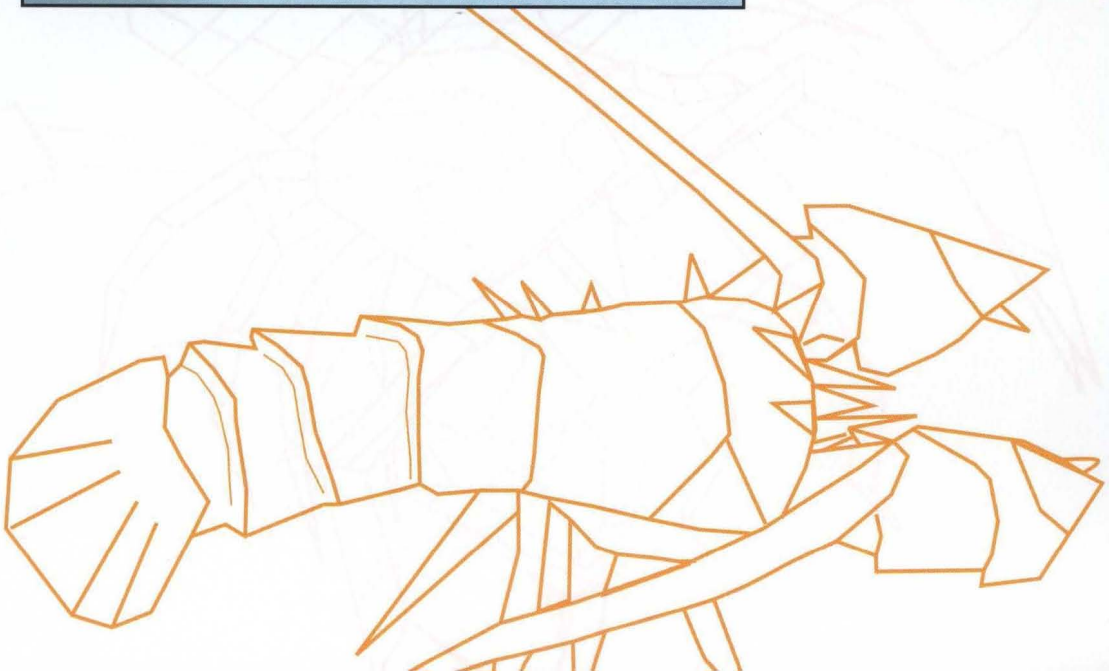



Pseudoescorpión

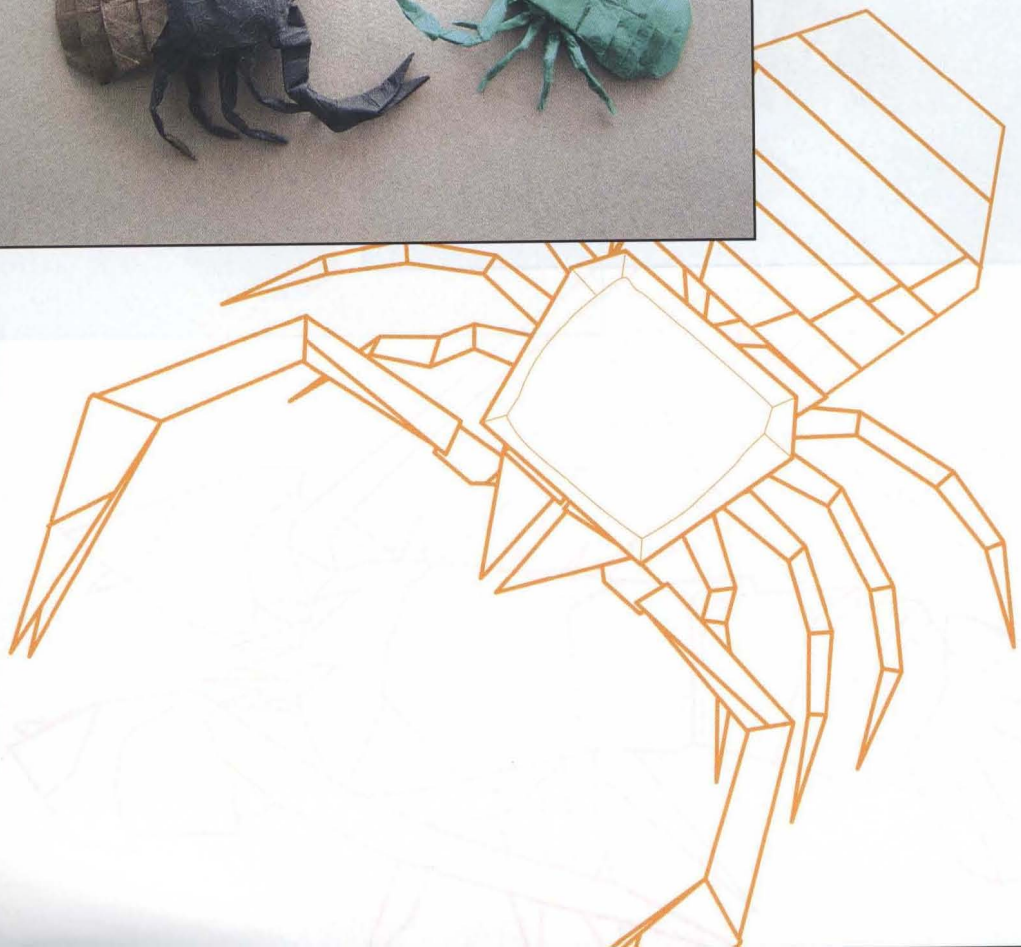



Escorpión Buthus

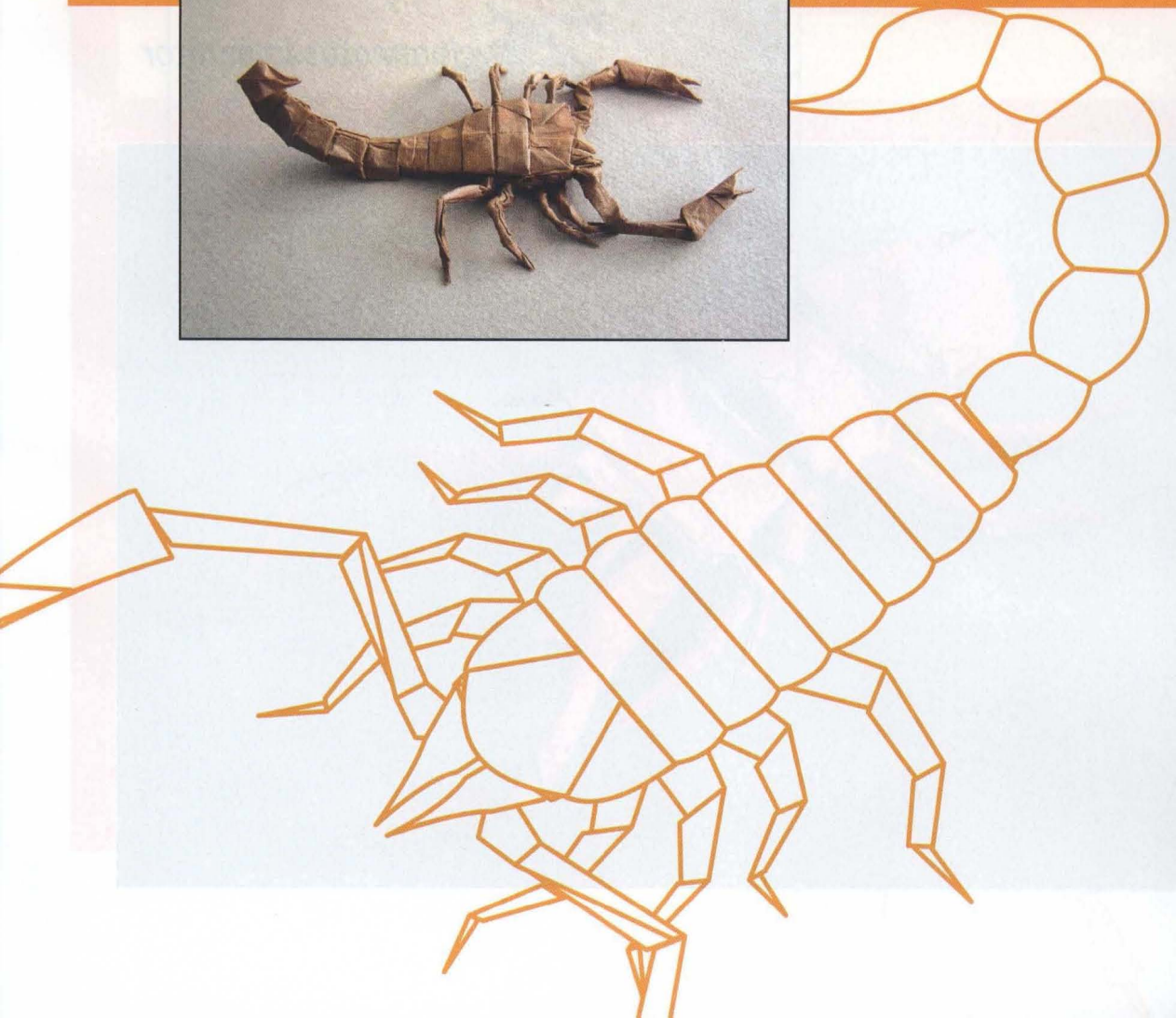
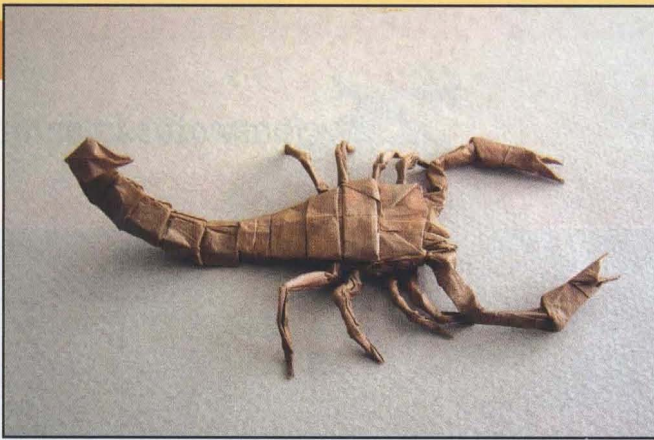

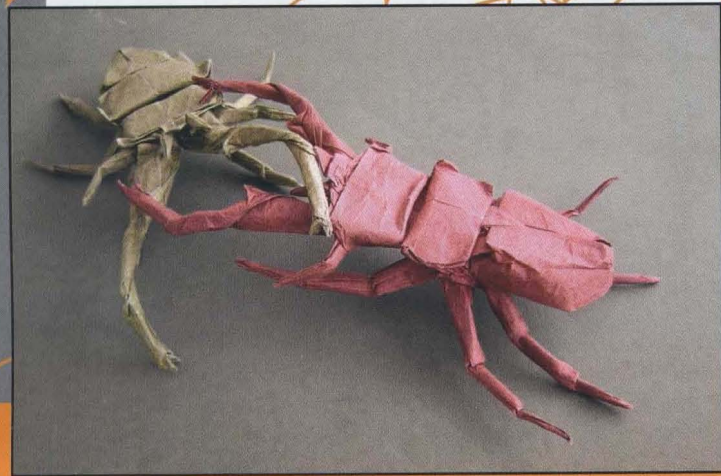

Cyclommatus Imperator

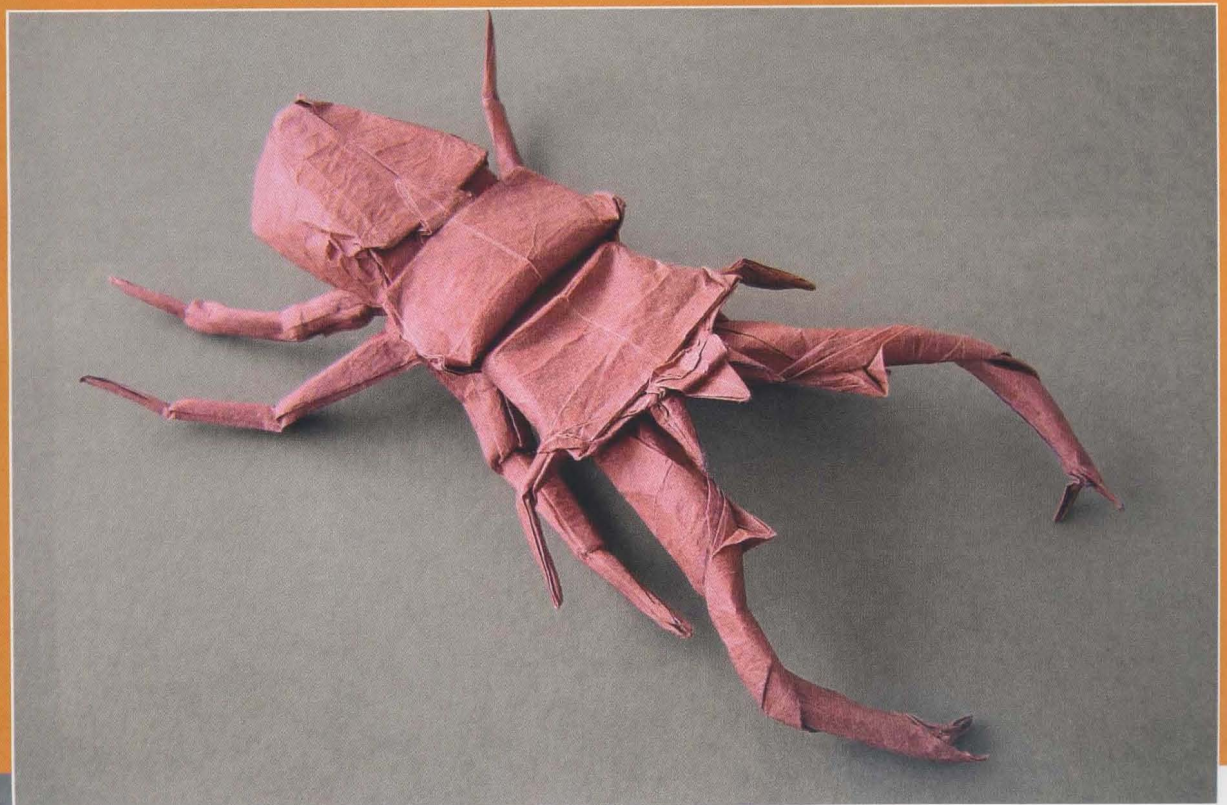



Ciervo volante

